

REQUEST FOR PROPOSALS (RFP) 1-3408

BUS STOP MAINTENANCE PROGRAM



**ORANGE COUNTY TRANSPORTATION AUTHORITY
550 South Main Street
P.O. Box 14184
Orange, CA 92863-1584
(714) 560-6282**

Key RFP Dates

Issue Date:	May 24, 2021
Pre-Proposal Conference Date:	June 9, 2021
Question Submittal Date:	June 17, 2021
Proposal Submittal Date:	July 6, 2021
Interview Date:	July 27, 2021

TABLE OF CONTENTS

SECTION I: INSTRUCTIONS TO OFFERORS	1
SECTION II: PROPOSAL CONTENT	7
SECTION III: EVALUATION AND AWARD	15
EXHIBIT A: SCOPE OF WORK.....	19
EXHIBIT B: COST AND PRICE FORMS	20
EXHIBIT C: PROPOSED AGREEMENT	22
EXHIBIT D: STATUS OF PAST AND PRESENT CONTRACTS FORM.....	23
EXHIBIT E: CAMPAIGN CONTRIBUTION DISCLOSURE FORM.....	25
EXHIBIT F: SAFETY SPECIFICATIONS	30
EXHIBIT G: PROPOSAL EXCEPTIONS AND/OR DEVIATIONS.....	31
EXHIBIT H: PUBLIC RECORDS ACT INDEMNIFICATION – PROPOSAL DOCUMENTS.....	33



May 24, 2021

NOTICE OF REQUEST FOR PROPOSALS (RFP)

RFP 1-3408: “BUS STOP MAINTENANCE PROGRAM”

TO: ALL OFFERORS

FROM: ORANGE COUNTY TRANSPORTATION AUTHORITY

The Orange County Transportation Authority (Authority) invites proposals from qualified contractors to provide bus stop maintenance. The budget for this project is \$1,534,578 for a three-year initial term.

Proposals must be submitted to the Authority at or before 2:00 p.m. on July 6, 2021.

Proposals must be submitted electronically through the following URL link: <https://www.octa.net/secure/UploadMyFile.aspx> at or before 2:00 p.m. on July 6, 2021. Select “RFP 1-3408” from the drop-down menu and follow the instructions as prompted.

PLEASE NOTE:

Hard copy proposal submission will not be accepted for this RFP. Proposals must be submitted electronically at the link stated above and by the date and time as indicated.

Proposals and amendments to proposals received after the date and time specified above will be returned to the Offerors unopened.

Firms interested in obtaining a copy of this RFP may do so by downloading the RFP from CAMM NET at <https://cammnet.octa.net>.

All firms interested in doing business with the Authority are required to register their business on-line at CAMM NET. The website can be found at <https://cammnet.octa.net>.

To receive all further information regarding this RFP 1-3408, firms and subcontractors must be registered on CAMM NET with at least one of the

following commodity codes for this solicitation selected as part of the vendor's on-line registration profile:

<u>Category:</u>	<u>Commodity:</u>
Maintenance Services - Facility	Janitorial - Cleaning Services
	Janitorial - Lot Sweeping
	Janitorial Services
	Trash Disposal Service
Maintenance Services - Equipment	Material Handling - Services

IN-PERSON ATTENDANCE IS NOT AVAILABLE

A pre-proposal conference will be held on June 9, 2021, at 10:00 a.m. **via a Skype Teleconference Meeting**. All prospective Offerors are encouraged to join the pre-proposal conference by calling either of the following numbers:

(714) 558-5200, 820238# (1)	English (United States)
(714) 560-5666, 820238# (1)	English (United States)

Conference ID: 820238

Callers are requested to dial in and **mute the call**.

For those who can access via a web browser, Authority will share its desktop and display the pre-proposal presentation online. For those who join by telephone, a copy of the pre-proposal conference presentation will be included in Addendum No. 1.

All prospective Offerors are encouraged to attend the pre-proposal conference.

The Authority has established July 27, 2021, as the date to conduct interviews. All prospective Offerors will be asked to keep this date available.

Offerors are encouraged to subcontract with small businesses to the maximum extent possible.

All Offerors will be required to comply with all applicable equal opportunity laws and regulations.

The award of this contract is subject to receipt of federal, state and/or local funds adequate to carry out the provisions of the proposed agreement including the identified Scope of Work.

SECTION I: INSTRUCTIONS TO OFFERORS

SECTION I. INSTRUCTIONS TO OFFERORS

A. PRE-PROPOSAL CONFERENCE

A pre-proposal conference will be held on June 9, 2021, at 10:00 a.m. **via a Skype Teleconference Meeting**. All prospective Offerors are encouraged to join the pre-proposal conference by calling either of the following numbers:

Join by phone

(714) 558-5200, 820238# (1)	English (United States)
(714) 560-5666, 820238# (1)	English (United States)

Conference ID: 820238

Callers are requested to dial in and mute the call.

For those who can access via a web browser, Authority will share its desktop and display the pre-proposal presentation online. For those who join by telephone, a copy of the pre-proposal conference presentation will be included in Addendum No. 1.

All prospective Offerors are encouraged to attend the pre-proposal conference.

B. EXAMINATION OF PROPOSAL DOCUMENTS

By submitting a proposal, Offeror represents that it has thoroughly examined and become familiar with the work required under this RFP and that it is capable of performing quality work to achieve the Authority's objectives.

C. ADDENDA

The Authority reserves the right to revise the RFP documents. Any Authority changes to the requirements will be made by written addendum to this RFP. Any written addenda issued pertaining to this RFP shall be incorporated into the terms and conditions of any resulting Agreement. The Authority will not be bound to any modifications to or deviations from the requirements set forth in this RFP as the result of oral instructions. Offerors shall acknowledge receipt of addenda in their proposals. Failure to acknowledge receipt of Addenda may cause the proposal to be deemed non-responsive to this RFP and be rejected.

D. AUTHORITY CONTACT

All communication and/or contacts with Authority staff regarding this RFP are to be directed to the following Contract Administrator:

Sue Ding
Contracts Administration and Materials Management Department
600 South Main Street
P.O. Box 14184
Orange, CA 92863-1584
Phone: 714.560.5631, Fax: 714.560.5792
Email: sding@octa.net

Commencing on the date of the issuance of this RFP and continuing until award of the contract or cancellation of this RFP, no proposer, subcontractor, lobbyist or agent hired by the proposer shall have any contact or communications regarding this RFP with any Authority's staff; member of the evaluation committee for this RFP; or any contractor or consultant involved with the procurement, other than the Contract Administrator named above or unless expressly permitted by this RFP. Contact includes face-to-face, telephone, electronic mail (e-mail) or formal written communication. Any proposer, subcontractor, lobbyist or agent hired by the proposer that engages in such prohibited communications may result in disqualification of the proposer at the sole discretion of the Authority.

E. CLARIFICATIONS

1. Examination of Documents

Should an Offeror require clarifications of this RFP, the Offeror shall notify the Authority in writing in accordance with Section E.2. below. Should it be found that the point in question is not clearly and fully set forth, the Authority will issue a written addendum clarifying the matter which will be sent to all firms registered on CAMM NET under the commodity codes specified in this RFP.

2. Submitting Requests

- a. All questions, including questions that could not be specifically answered at the pre-proposal conference must be put in writing and must be received via email to sding@octa.net by the Authority no later than 5:00 p.m., on June 17, 2021.
- b. Requests for clarifications, questions and comments must be clearly labeled, "Written Questions". The Authority is not responsible for failure to respond to a request that has not been labeled as such.

3. Authority Responses

Responses from the Authority will be posted on CAMM NET, no later than June 24, 2021. Offerors may download responses from CAMM NET at <https://cammnet.octa.net>, or request responses be sent via U.S. Mail by emailing or faxing the request to Sue Ding, Senior Contract Administrator.

To receive email notification of Authority responses when they are posted on CAMM NET, firms and subcontractor must be registered on CAMM NET with at least one of the following commodity codes for this solicitation selected as part of the vendor's on-line registration profile:

<u>Category:</u>	<u>Commodity:</u>
Maintenance Services - Facility	Janitorial - Cleaning Services
	Janitorial - Lot Sweeping
	Janitorial Services
	Trash Disposal Service
Maintenance Services - Equipment	Material Handling - Services

Inquiries received after 5:00 p.m. on June 17, 2021 will not be responded to.

F. SUBMISSION OF PROPOSALS

Offeror is responsible for ensuring third-party deliveries arrive at the time and place as indicated in this RFP.

1. Date and Time

Proposals must be submitted electronically through the following URL link: https://www.octa.net/Proposal_Upload_Link at or before 2:00 p.m. on July 6, 2021. Select "RFP 1-3408" from the drop-down menu and follow the instructions as prompted.

PLEASE NOTE:

Hard copy proposal submission will not be accepted for this RFP. Proposals must be submitted electronically at the link stated above and by the date and time as indicated.

2. Acceptance of Proposals

- a. The Authority reserves the right to accept or reject any and all proposals, or any item or part thereof, or to waive any informalities or irregularities in proposals.
- b. The Authority reserves the right to withdraw or cancel this RFP at

any time without prior notice and the Authority makes no representations that any contract will be awarded to any Offeror responding to this RFP.

- c. The Authority reserves the right to issue a new RFP for the project.
- d. The Authority reserves the right to postpone proposal openings for its own convenience.
- e. Each proposal will be received with the understanding that acceptance by the Authority of the proposal to provide the services described herein shall constitute a contract between the Offeror and Authority which shall bind the Offeror on its part to furnish and deliver at the prices given and in accordance with conditions of said accepted proposal and specifications.
- f. The Authority reserves the right to investigate the qualifications of any Offeror, and/or require additional evidence of qualifications to perform the work.
- g. Submitted proposals are not to be copyrighted.

G. PRE-CONTRACTUAL EXPENSES

The Authority shall not, in any event, be liable for any pre-contractual expenses incurred by Offeror in the preparation of its proposal. Offeror shall not include any such expenses as part of its proposal.

Pre-contractual expenses are defined as expenses incurred by Offeror in:

- 1. Preparing its proposal in response to this RFP;
- 2. Submitting that proposal to the Authority;
- 3. Negotiating with the Authority any matter related to this proposal; or
- 4. Any other expenses incurred by Offeror prior to date of award, if any, of the Agreement.

H. JOINT OFFERS

Where two or more firms desire to submit a single proposal in response to this RFP, they should do so on a prime-subcontractor basis rather than as a joint venture. The Authority intends to contract with a single firm and not with multiple firms doing business as a joint venture.

I. TAXES

Offerors' proposals are subject to State and Local sales taxes. However, the Authority is exempt from the payment of Federal Excise and Transportation Taxes.

Offeror is responsible for payment of all taxes for any goods, services, processes and operations incidental to or involved in the contract.

J. PROTEST PROCEDURES

The Authority has on file a set of written protest procedures applicable to this solicitation that may be obtained by contacting the Contract Administrator responsible for this procurement. Any protests filed by an Offeror in connection with this RFP must be submitted in accordance with the Authority's written procedures.

K. CONTRACT TYPE

It is anticipated that the Agreement resulting from this solicitation, if awarded, will be based on firm-fixed service fees to perform monthly preventative maintenance service and other work as needed, for a three-year initial term with two, two-year option terms.

L. CONFLICT OF INTEREST

All Offerors responding to this RFP must avoid organizational conflicts of interest which would restrict full and open competition in this procurement. An organizational conflict of interest means that due to other activities, relationships or contracts, an Offeror is unable, or potentially unable to render impartial assistance or advice to the Authority; an Offeror's objectivity in performing the work identified in the Scope of Work is or might be otherwise impaired; or an Offeror has an unfair competitive advantage. Conflict of Interest issues must be fully disclosed in the Offeror's proposal.

All Offerors must disclose in their proposal and immediately throughout the course of the evaluation process if they have hired or retained an advocate to lobby Authority staff or the Board of Directors on their behalf.

Offerors hired to perform services for the Authority are prohibited from concurrently acting as an advocate for another firm who is competing for a contract with the Authority, either as a prime or subcontractor.

M. CODE OF CONDUCT

All Offerors agree to comply with the Authority's Code of Conduct as it relates to Third-Party contracts which is hereby referenced and by this reference is incorporated herein. All Offerors agree to include these requirements in all of its subcontracts.

SECTION II: PROPOSAL CONTENT

SECTION II. PROPOSAL CONTENT

A. PROPOSAL FORMAT AND CONTENT

1. Format

Proposals should be typed with a standard 12-point font, double-spaced. Proposals should not include any unnecessarily elaborate or promotional materials. Proposals should not exceed fifty (50) pages in length, excluding any appendices, cover letters, resumes, or forms.

2. Letter of Transmittal

The Letter of Transmittal shall be addressed to Sue Ding, Sr. Contract Administrator and must, at a minimum, contain the following:

- a. Identification of Offeror that will have contractual responsibility with the Authority. Identification shall include legal name of company, corporate address, telephone and fax number, and email address. Include name, title, address, email address, and telephone number of the contact person identified during period of proposal evaluation.
- b. Identification of all proposed subcontractors including legal name of company, contact person's name and address, phone number and fax number, and email address; relationship between Offeror and subcontractors, if applicable.
- c. Acknowledgement of receipt of all RFP addenda, if any.
- d. A statement to the effect that the proposal shall remain valid for a period of not less than 120 days from the date of submittal.
- e. Signature of a person authorized to bind Offeror to the terms of the proposal.
- f. Signed statement attesting that all information submitted with the proposal is true and correct.

3. Technical Proposal

a. Qualifications, Related Experience and References of Offeror

This section of the proposal should establish the ability of Offeror to satisfactorily perform the required work by reasons of: experience in performing work of a similar nature; demonstrated competence in the services to be provided; strength and stability of the firm; staffing

capability; work load; record of meeting schedules on similar projects; and supportive client references.

Offeror to:

- (1) Provide a brief profile of the firm, including the types of services offered; the year founded; form of the organization (corporation, partnership, sole proprietorship); number, size and location of offices; and number of employees.
- (2) Provide a general description of the firm's financial condition and identify any conditions (e.g., bankruptcy, pending litigation, planned office closures, impending merger) that may impede Offeror's ability to complete the project.
- (3) Describe the firm's experience in performing work of a similar nature to that solicited in this RFP, and highlight the participation in such work by the key personnel proposed for assignment to this project. Describe experience in working with the various government agencies identified in this RFP.
- (4) Possess a current "C-61 Limited Specialty" license, with a D-42 classification, issued by the Contractors State License Board, for the entire length of the contract.
- (5) Have a minimum of three (3) years of direct experience working with local, county, state, and/or federal agencies.
- (6) Have a minimum of three (3) years of continuous experience maintaining, installing, relocating, and removing street signs and posts, along with extensive experience using core drills, pneumatic tools, and various other power hand tools.
- (7) Have a minimum of three (3) years of experience preparing and painting various surfaces, such as concrete or asphalt.
- (8) Have a minimum three (3) years of experience using current standards and practices for trimming and pruning trees and shrubbery.
- (9) Have experience working in and around extreme traffic conditions along streets, roadways, and major arterial highways. This experience will include the following:
 - The proper placement and utilization of portable traffic diversion devices such as cones, delineators, and barricades.

- The proper placement and operation of mechanical arrow boards or other directional devices used to direct motorists in and around construction zones.
- (10) Identify subcontractors by company name, address, contact person, telephone number, email, and project function. Describe Offeror's experience working with each subcontractor.
 - (11) Identify all firms hired or retained to provide lobbying or advocating services on behalf of the Offeror by company name, address, contact person, telephone number and email address. This information is required to be provided by the Offeror immediately during the evaluation process, if a lobbyist or advocate is hired or retained.
 - (12) Provide as a minimum three (3) references for the projects cited as related experience, and furnish the name, title, address, telephone number, and email address of the person(s) at the client organization who is most knowledgeable about the work performed. Offeror may also supply references from other work not cited in this section as related experience.

b. Proposed Staffing and Project Organization

This section of the proposal should establish the method, which will be used by the Offeror to manage the project as well as identify key personnel assigned.

Offeror to:

- (1) Identify key personnel proposed to perform the work in the specified scope of work and include major areas of subcontract work. Include the person's name, current location, proposed position for this project, current assignment, level of commitment to that assignment, availability for this assignment and how long each person has been with the firm.
- (2) Furnish brief resumes (not more than two [2] pages each) for the proposed Project Manager and other key personnel that includes education, experience, and applicable professional credentials.
- (3) Include a project organization chart, which clearly delineates communication/reporting relationships among the project staff.
- (4) Include a statement that key personnel will be available to the extent proposed for the duration of the project acknowledging

that no person designated as "key" to the project shall be removed or replaced without the prior written concurrence of the Authority.

c. Work Plan

Offeror should provide a narrative, which addresses the Scope of Work, and shows Offeror's understanding of Authority's needs and requirements.

Offeror to:

- (1) Describe the approach to completing the services specified in the Scope of Work. The approach to the work plan shall be of such detail to demonstrate the Offeror's ability to accomplish the project objectives and overall schedule.
- (2) Outline sequentially the activities that would be undertaken in completing the work and specify who would perform them.
- (3) Identify methods that Offeror will use to ensure quality control as well as budget and schedule control for the project.
- (4) Identify any special issues or problems that are likely to be encountered in this project and how the Offeror would propose to address them.
- (5) Offeror is encouraged to propose enhancements or procedural or technical innovations to the Scope of Work that do not materially deviate from the objectives or required content of the project.

d. Exceptions/Deviations

State any technical and/or contractual exceptions and/or deviations from the requirements of this RFP, including the Authority's technical requirements and contractual terms and conditions set forth in the Scope of Work (Exhibit A) and Proposed Agreement (Exhibit C), using the form entitled "Proposal Exceptions and/or Deviations" included in this RFP. This Proposal Exceptions and/or Deviations form must be included in the original proposal submitted by the Offeror. If no technical or contractual exceptions and/or deviations are submitted as part of the original proposal, Offerors are deemed to have accepted the Authority's technical requirements and contractual terms and conditions set forth in the Scope of Work (Exhibit A) and Proposed Agreement (Exhibit C). Offerors will not be allowed to submit the Proposal Exceptions and/or Deviations form or any technical and/or contractual exceptions after the proposal

submittal date identified in the RFP. Exceptions and/or deviations submitted after the proposal submittal date will not be reviewed by Authority.

All exceptions and/or deviations will be reviewed by the Authority and will be assigned a “pass” or “fail” status. Exceptions and deviations that “pass” do not mean that the Authority has accepted the change but that it is a potential negotiable issue. Exceptions and deviations that receive a “fail” status means that the requested change is not something that the Authority would consider a potential negotiable issue. Offerors that receive a “fail” status on their exceptions and/or deviations will be notified by the Authority and will be allowed to retract the exception and/or deviation and continue in the evaluation process. Any exceptions and/or deviation that receive a “fail” status and the Offeror cannot or does not retract the requested change may result in the firm being eliminated from further evaluation.

e. Public Records Act Indemnification

Proposals received by Authority are subject to the California Public Records Act, Government Code section 6250 et seq. (the “Act”), except as otherwise provided in the Act. Proposers should familiarize themselves and exceptions thereto. In no event shall the Authority or any of its agents, representatives, contractor, directors, officers, or employees be liable to a Proposer for the disclosure of any materials or information submitted in response to the RFP. Proposers must complete and sign the Exhibit H, Public Records Act Indemnification – Proposal Documents, and submit it with the proposal. Failure to complete Exhibit H may cause the proposal to be deemed non-responsive to this RFP and may no longer continue in the evaluation process.

If a California Public Records Act request is received by Authority for the release of information identified by Proposer as propriety, trade secret, or confidential, the request will be referred to Proposer for review and consideration. If Proposer requests that the information be withheld from release, Proposer shall provide such request in writing with the legal basis under the Act for each requested withholding. Failure to notify the Authority in writing of its desire to withhold the records within three business days and/or to timely provide a legal basis for the withholding of documents, regardless of any marking or designation of such documents, shall constitute a waiver of any claims Proposer may have had related to such disclosure.

Authority will review the request, determine if the disclosure of the records is required by law, and notify Proposer of such

determination. If Authority determines that the disclosure of records is required by law, Authority will notify Proposer of such determination and provide Proposer the opportunity to seek a protective order or other appropriate legal relief to protect the records.

Proposer shall defend and hold harmless Authority from any legal action arising from such withholding, as further detailed in Exhibit H, Public Records Act Indemnification – Proposal Documents.

4. Cost and Price Proposal

As part of the cost and price proposal, the Offeror shall submit proposed pricing to provide the services described in Exhibit A, Scope of Work.

The Offeror shall complete the "Price Summary Sheet" form included with this RFP (Exhibit B), and furnish any narrative required to explain the prices quoted in the schedules. It is anticipated that the Authority will issue a time and expense-price contract specifying monthly fixed fee and fully burdened labor rates for the work.

5. Appendices

Information considered by Offeror to be pertinent to this project and which has not been specifically solicited in any of the aforementioned sections may be placed in a separate appendix section. Offerors are cautioned, however, that this does not constitute an invitation to submit large amounts of extraneous materials. Appendices should be relevant and brief.

B. FORMS

1. Campaign Contribution Disclosure Form

In conformance with the statutory requirements of the State of California Government Code Section 84308, part of the Political Reform Act and Title 2, California Code of Regulations 18438 through 18438.8, regarding campaign contributions to members of appointed Board of Directors, Offeror is required to complete and sign the Campaign Contribution Disclosure Form provided in this RFP and submit as part of the proposal.

This form **must** be completed regardless of whether a campaign contribution has been made or not and regardless of the amount of the contribution.

The prime contractor, subcontractor, lobbyists and agents are required to report all campaign contributions made from the proposal submittal date up to and until the Board of Directors makes a selection.

2. Status of Past and Present Contracts Form

Offeror shall complete and sign the form entitled “Status of Past and Present Contracts” provided in this RFP and submit as part of its proposal. Offeror shall identify the status of past and present contracts where the firm has either provided services as a prime vendor or a subcontractor during the past five (5) years in which the contract has been the subject of or may be involved in litigation with the contracting authority. This includes, but is not limited to, claims, settlement agreements, arbitrations, administrative proceedings, and investigations arising out of the contract. Offeror shall have an ongoing obligation to update the Authority with any changes to the identified contracts and any new litigation, claims, settlement agreements, arbitrations, administrative proceedings, or investigations that arise subsequent to the submission of Offeror's proposal.

A separate form must be completed for each identified contract. Each form must be signed by the Offeror confirming that the information provided is true and accurate.

3. Proposal Exceptions and/or Deviations Form

Offerors shall complete the form entitled “Proposal Exceptions and/or Deviations” provided in this RFP and submit it as part of the original proposal. For each exception and/or deviation, a new form should be used, identifying the exception and/or deviation and the rationale for requesting the change. Exceptions and/or deviations submitted after the proposal submittal date will not be reviewed nor considered by the Authority.

4. Public Records Act Indemnification Form

Offerors shall complete and sign the form entitled “Public Records Act Indemnification” provided in this RFP and submit it as part of the original proposal. Proposers must complete and sign either Option 1 or Option 2 whichever applies.

SECTION III: EVALUATION AND AWARD

SECTION III. EVALUATION AND AWARD

A. EVALUATION CRITERIA

The Authority will evaluate the offers received based on the following criteria:

1. **Qualifications of the Firm** **25%**

 Technical experience in performing work of a closely similar nature; strength and stability of the firm; strength, stability, experience and technical competence of subcontractors; assessment by client references.
2. **Staffing and Project Organization** **15%**

 Qualifications of project staff, particularly key personnel and especially the Project Manager; key personnel's level of involvement in performing related work cited in "Qualifications of the Firm" section; logic of project organization; adequacy of labor commitment; concurrence in the restrictions on changes in key personnel.
3. **Work Plan** **30%**

 Depth of Offeror's understanding of Authority's requirements and overall quality of work plan; logic, clarity and specificity of work plan; appropriateness of resource allocation among the work; reasonableness of proposed schedule; utility of suggested technical or procedural innovations.
4. **Cost and Price** **30%**

 Reasonableness of the monthly fixed fee and fully-burdened labor rates for the services outlined in Exhibit A, Scope of Work included in this RFP; competitiveness with other offers received; adequacy of data in support of figures quoted.

B. EVALUATION PROCEDURE

An evaluation committee will be appointed to review all proposals received for this RFP. The committee is comprised of Authority staff and may include outside personnel. The committee members will evaluate the written proposals using criteria identified in Section III A. A list of top-ranked proposals, firms within a competitive range, will be developed based upon the totals of each committee members' score for each proposal.

During the evaluation period, the Authority may interview some or all of the proposing firms. The Authority has established July 27, 2021, as the date to conduct interviews. All prospective Offerors are asked to keep this date available.

No other interview dates will be provided, therefore, if an Offeror is unable to attend the interview on this date, its proposal may be eliminated from further discussion. The interview may consist of a short presentation by the Offeror after which the evaluation committee will ask questions related to the firm's proposal and qualifications.

At the conclusion of the proposal evaluations, Offerors remaining within the competitive range may be asked to submit a Best and Final Offer (BAFO). In the BAFO request, the firms may be asked to provide additional information, confirm or clarify issues and submit a final cost/price offer. A deadline for submission will be stipulated.

At the conclusion of the evaluation process, the evaluation committee will recommend to the Transit Committee, the Offeror with the highest final ranking or a short list of top ranked firms within the competitive range whose proposal(s) is most advantageous to the Authority. The Board Committee will review the evaluation committee's recommendation and forward its decision to the full Board of Directors for final action.

C. AWARD

The Authority will evaluate the proposals received and will submit, with approval of the Transit Committee, the proposal considered to be the most competitive to the Authority's Board of Directors, for consideration and selection. The Authority may also negotiate contract terms with the selected Offeror prior to award, and expressly reserves the right to negotiate with several Offerors simultaneously and, thereafter, to award a contract to the Offeror offering the most favorable terms to the Authority.

The Authority reserves the right to award its total requirements to one Offeror or to apportion those requirements among several Offerors as the Authority may deem to be in its best interest. In addition, negotiations may or may not be conducted with Offerors; therefore, the proposal submitted should contain Offeror's most favorable terms and conditions, since the selection and award may be made without discussion with any Offeror.

The selected Offeror will be required to submit to the Authority's Accounting department a current IRS W-9 form prior to commencing work.

D. NOTIFICATION OF AWARD AND DEBRIEFING

Offerors who submit a proposal in response to this RFP shall be notified via CAMM NET of the contract award. Such notification shall be made within three (3) business days of the date the contract is awarded.

Offerors who were not awarded the contract may obtain a debriefing concerning the strengths and weaknesses of their proposal. Unsuccessful Offerors, who wish

to be debriefed, must request the debriefing in writing or electronic mail and the Authority must receive it within three (3) business days of notification of the contract award.

EXHIBIT A: SCOPE OF WORK

**SCOPE OF WORK
Bus Stop Maintenance Program**

Objective:

The Contractor shall provide the services to perform on-going general maintenance at each of the Orange County Transportation Authority's (OCTA) existing bus stop locations within Orange, Los Angeles, San Bernardino, and Riverside Counties. All bus stops will be maintained on a regular and continuous basis to ensure they are safe, clean, and in good condition.

Background:

OCTA operates sixty (60) individual bus routes providing service to all of Orange County, as well as several cities in neighboring counties (see Attachment 1). These routes currently service approximately five thousand, four hundred eighty (5,480) bus stop locations, with some of the smaller "Express" routes servicing as few as ten (10) stops and the local fixed routes servicing as many as one hundred fifty (150) stop locations.

The Contractor shall be responsible for performing preventive maintenance at each bus stop location on a pre-determined schedule or cycle, as well as performing other maintenance related tasks.

Along with performing preventive maintenance, the Contractor shall be issued miscellaneous maintenance or emergency work orders on a regular basis. The work covers a variety of issues including, but not limited to removing graffiti, replacing damaged signs/posts, trimming trees, painting red curbs, moving benches, repairing solar lights, etc.

Work orders shall also be issued for each of OCTA's three service changes each year. These work orders vary in scope, and include installing or removing bus stop signs, posts, mounting hardware, informational materials, route schedules, etc.

Contractor's Qualifications:

- 1) The Contractor will possess a current "C-61 Limited Specialty" license, with a D-42 classification, issued by the Contractors State License Board, for the entire length of the contract. If the Contractor does not remain in good standing and the license is revoked or suspended, the Contractor will notify OCTA within ten (10) working days from the date the license was revoked or suspended.

It is recommended but not required, that the Contractor also possesses a "C-61 Limited Specialty" license, with one or more of the following classifications:

- D-63- Construction Clean-up Contractor
- D-34- Prefabricated Equipment Contractor
- D-38- Sand and Water Blasting

2) Obtain a business license(s) and/or permit(s) if required by a local jurisdiction or public agency.

Note: The Contractor **shall** be responsible for all costs or fees associated with obtaining the license and/or permit.

3) Must have a minimum of three (3) years of direct experience working with local, county, state, and/or federal agencies.

4) Must have a minimum of three (3) years of continuous experience maintaining, installing, relocating, and removing street signs and posts, along with extensive experience using core drills, pneumatic tools, and various other power hand tools.

5) Must have a minimum of three (3) years of experience preparing and painting various surfaces, such as concrete or asphalt.

6) Must have a minimum of three (3) years of experience using current standards and practices for trimming and pruning trees and shrubbery.

7) Must have experience working in and around extreme traffic conditions along streets, roadways, and major arterial highways. This experience will include the following:

- The proper placement and utilization of portable traffic diversion devices such as cones, delineators, and barricades.
- The proper placement and operation of mechanical arrow boards or other directional devices used to direct motorists in and around construction zones.

Contractor's Requirements:

Over the course of the maintenance contract, the Contractor will be required to:

1) Maintain an adequate fleet of service vehicles, trucks, and/or trailers large enough to transport equipment, hardware, materials, and/or supplies needed to complete each daily task and/or assignment.

- 2) The Contractor will equip each service vehicle and/or truck with 2-way radios, cell phones, or other communication equipment and will be in direct contact with all maintenance personnel while they are in the field.
- 3) Service vehicles and/or trucks will be equipped with an amber/yellow warning light bar mounted on top of each vehicle in a location that is clearly visible to motorists approaching from the rear of the vehicle. Each light bar will be equipped with multiple rotating strobe lights, along with a multi-directional arrow bar and must follow all laws and regulations.
- 4) Have an established maintenance facility and/or warehouse with office space. The facility must be large enough to accommodate all service vehicles, trailers, trash dumpsters, hardware, materials, and supplies needed to perform the day-to-day work assignments.

Note: All OCTA equipment, materials, supplies, or hardware issued to the Contractor will be locked-up and properly secured prior to leaving the maintenance facility at the close of business each day. The Contractor will be responsible for missing and/or damaged materials and will reimburse OCTA for any costs associated with replacing the materials/hardware.

Also, it is recommended (but not required) that the maintenance facility be located within a reasonable distance (+/- 30-minute drive) from OCTA's Administrative Offices, located at 550 South Main Street, Orange, CA 92868, to ensure the Contractor is able to pick up assignments, work orders, materials, or other miscellaneous items in a timely manner.

- 5) The office will be staffed with a minimum of one (1) employee during normal business hours to handle the administrative functions, report problems or issues, respond to questions or inquires, receive and issue work orders, etc.
- 6) The office will be equipped with a computer, e-mail service, fax machine, telephone, and answering machine.
- 7) Allow OCTA personnel access to the maintenance facility during normal business hours.
- 8) Maintain a twenty-four (24)-hour emergency telephone number.
- 9) Provide and maintain a sufficient work force qualified to perform all required maintenance and tasks outlined in the Scope of Work.

Note: The Contractor will verify the work status of all employees to ensure they have a legal right to work in the United States.

- 10) Be required to dispose of all trash and debris removed from each bus stop location. The trash and debris will be properly disposed of in compliance with all state and local laws and regulations.

Note: Under no circumstance will the Contractor or its employees dispose of or discard any trash or debris in privately owned trash receptacles, dumpsters, or at any unauthorized locations.

- 11) The Contractor will be required to maintain Material Safety Data Sheets (MSDS) for all chemicals and/ or other substances used to maintain OCTA bus stops. Upon request, the Contractor will provide a copy of all MSDS sheets to OCTA.
- 12) The Contractor will provide OCTA with a copy of the Contractor's safety policy or manual, as outlined in Exhibit ___.
- 13) Contractor must comply with the additional safety requirements as set forth in Attachment 23, titled "Additional Required Safe Work Practices".
- 14) All work performed at each bus stop location will be documented in English, and the documentation will be maintained at the Contractor's place of business. Upon request, the Contractor will provide OCTA with a copy of any or all documentation related to the maintenance and upkeep of each bus stop location during the course of the contract.
- 15) Contractor is required to conduct criminal background checks for all personnel assigned to the maintenance of OCTA property. Contractor is required to determine those convictions that would disqualify personnel from working on OCTA property. Convictions that have been subsequently dismissed, sealed, expunged, pardoned or statutorily eradicated need not be listed. California residents need not list convictions for marijuana-related misdemeanor offenses that are more than two years old. If an applicant states they have been convicted of a crime, the applicant is required to state nature of the crime(s), when and where convicted, and disposition of the case. No applicant can be automatically denied employment with the Contractor solely on the grounds of a criminal offense. The nature of the offense, date of the offense, the surrounding circumstances and the relevance of the offense to the position(s) applied for may, however, be considered.
- 16) During the course of the contract, the total number of active bus stops will fluctuate, but these changes should not vary by more than \pm five (5) percent. When changes occur, OCTA will submit a list of all bus stop modifications (new stop locations and/or deleted stops) to the Contractor approximately four (4) to six (6) weeks prior to an upcoming service change.
- 17) Service changes occur on the second Sunday in February, June, and October, and the Contractor will ensure that adequate labor is readily available to perform the required work.

Task 1 - Bus Stop Preventive Maintenance:

The Contractor will be responsible for performing preventive maintenance at each of the roughly 5,480 bus stop locations within OCTA's service area (see Attachment 2). Each bus stop will be inspected and serviced a minimum of once every four (4) weeks, or thirteen (13) times per contract year. When servicing a bus stop location, the Contractor will perform the following inspections and/or maintenance:

- 1) Repair or replace damaged or missing bus stop signs, posts, post anchors, anchor sleeves, or mounting hardware.
- 2) Repair or replace damaged or missing informational cassettes, cassette shields, transit tubes, or mounting hardware.
- 3) Replace or remove any discolored, damaged, or otherwise unreadable route information or schedules.
- 4) Inspect any city signs and posts within the bus zone. If damaged, notify the local jurisdiction within twenty-four (24) hours of servicing the stop.
- 5) Test, repair, or replace any inoperative solar lighting units.
- 6) Remove all trash and debris in and around the bus stop boarding area including tree wells, planters, hedges, underneath street furniture, or other objects.
- 7) Remove all loose trash, debris, or other items that may be lodged at the bottom of trash receptacle. Place a new trash bag and secure it to the receptacle.

Note: Do not empty trash receptacles belonging to a local agency or private company, except under the following conditions:

When trash accumulates and has stacked up above the rim of the container, remove just enough trash (to a level roughly six (6) to eight (8) inches below the rim of the container) to minimize spillage onto the sidewalk area. Notify the owner of the trash receptacles within twenty-four (24) hours of servicing the bus stop.

- 8) Remove all unsanitary items or materials, and if needed wash down the affected area to eliminate any remaining residue.
- 9) Sweep off and remove all dirt, leaves, cigarette butts, or other objects from the sidewalk, passenger boarding area, underneath street furniture, and along the gutter adjacent to the bus zone.

- 10) Remove any shopping carts found within the passenger boarding area. All carts must be moved to an area away from the bus zone and secured to prevent them from rolling into the street, parked vehicles, or other objects.
- 11) Wipe down and clean off all dirt, grime, stains, or other substances found on the bus stop sign, post, or other OCTA hardware.
- 12) Remove any graffiti and/or unauthorized items found on the bus stop or city sign and post, such as paint, ink markings, decals, stickers, campaign signs, garage sale signs, etc.

Note: Any graffiti found on city or privately-owned property (i.e. benches, shelters, newsstands, etc.) and covers an area of roughly twelve (12) inches squared will be removed. Graffiti covering a larger area will be reported to the local jurisdiction and/or private property owner within twenty-four (24) hours of servicing the stop.

- 13) Any graffiti that is offensive in nature will be removed as soon as possible. If the Contractor is unable to completely remove the markings, then the local jurisdiction must be notified as soon as possible, but no later than twenty-four (24) hours after the bus stop has been serviced.
- 14) Inspect the sidewalk/boarding area for potential safety issues or hazards, which includes, but is not limited to the following:
 - a. Uneven or raised surfaces more than 3/4" high.
 - b. Damaged or cracked sidewalks or pathways.
 - c. Objects protruding out of the sidewalk or pathway.
 - d. Water leakage from broken water lines, sprinklers, or other sources.
 - e. Damaged or broken utility boxes, covers or lids (i.e. water meters, pull boxes, etc.)
 - f. Hazardous waste materials.
 - g. Vandalized or damaged benches, shelters, or other objects.
 - h. Tree branch(es) extending over the sidewalk/boarding area, less than seven (7) feet above grade.

Note: If any safety issues or hazards are found, all necessary measures will be taken to minimize or eliminate the potential risks to the public. If required, the local jurisdiction and/or property owner(s) will be notified as soon as possible, but no later than twenty-four (24) hours after the bus stop has been serviced.

Notification will be via e-mail or fax, and a copy of the transmittal will be forwarded to OCTA.

15) Inspect the roadway on both the approach and departure side of the bus zone for roadway damage, safety issues, or hazards that could potentially damage a bus pulling into or out of the bus zone. Hazards may include, but are not limited to the following:

- a. Potholes or uneven roadway surfaces.
- b. Cracked or broken sections of the curb/gutter along the length of the bus zone.
- c. Uneven surfaces, cracked, broken, or other damages to utility boxes or vaults (i.e. storm drains, manholes, underground electrical vaults, etc.)
- d. Tree branches extending into the street less than 14 feet above the roadway.

Note: If any safety issues or hazards are found, all necessary measures will be taken to minimize or eliminate the potential risks to the public. If required, the local jurisdiction and/or property owner(s) will be notified as soon as possible.

Notification will be via e-mail or fax, and a copy of the transmittal will be forwarded to OCTA.

Documentation of Task 1 Maintenance:

All work performed while performing "Preventive Maintenance" will be clearly documented and if follow-up work is required, the appropriate agency(ies) and/or property owner(s) will be notified within twenty-four (24) hours of servicing the bus stop(s). The person performing the maintenance will sign their name at the bottom of each route page and note the date the work was completed.

All documentation will be legible, written in English, and maintained at the Contractor's place of business. Upon request, the Contractor will provide OCTA with any or all documentation associated with the bus stop maintenance program.

TASK 2 - City Assistance Program:

In the event a city does not have the resources or is otherwise unable to meet their obligations for maintaining the bus stop locations, they will have the opportunity to participate in what is known as the "City Assistance Program" (CAP).

Cities participating in this program will provide OCTA with a list of stop locations and the frequency in which these stops will be maintained (once a week, twice a week, etc.) The Contractor will then be required to service each of these locations and perform the sub-tasks as outlined below.

This program is designed in such a way as to allow cities the opportunity to add new stop locations, remove stops from the program, change the service frequency, withdraw completely and/or join the assistance program at their discretion. With this flexibility, there is no guarantee

to the actual number of bus stops that will be serviced from month to month. In view of this, the Contractor will invoice OCTA a "per stop/per visit" fee instead of a firm-fixed monthly preventive maintenance rate.

- 1) Sweep off and remove all dirt, leaves, cigarette butts, or other objects from the sidewalk, passenger boarding area, underneath street furniture, and along the gutter adjacent to the bus zone.
- 2) Remove any unattended shopping carts found within the passenger boarding area. All carts will be moved to an area away from the bus zone and secured to prevent them from rolling into the street, parked vehicles, or other objects.
- 3) Wipe down and clean off all dirt, grime, stains, or other substances found on the bus stop sign, post, or other OCTA hardware.
- 4) Remove any graffiti and/or unauthorized items found on the bus stop or city sign and post, such as paint, ink markings, decals, stickers, campaign signs, garage sale signs, etc.

Note: Any graffiti found on city or privately-owned property (i.e. benches, shelters, newsstands, etc.) covering an area of roughly twelve (12) inches squared will be removed. Graffiti covering a larger area will be reported to the local jurisdiction and/or private property owner within twenty-four (24) hours of servicing the stop.

- 5) Any graffiti that is offensive in nature will be removed as soon as possible. If the Contractor is unable to completely remove the markings, then the local jurisdiction will be notified within twenty-four (24) hours.
- 6) Inspect the sidewalk/boarding area within 18 feet from both sides of the bus stop zone for potential safety issues or hazards, which could include, but are not limited to the following:
 - a. Uneven or raised surfaces more than 3/4" high.
 - b. Damaged or cracked sidewalks or pathways.
 - c. Objects protruding out of the sidewalk or pathway.
 - d. Water leakage from broken water lines, sprinklers, or other sources.
 - e. Damaged or broken utility boxes, covers or lids (i.e. water meters, pull boxes, etc.).
 - f. Hazardous materials or waste. Identify unsanitary areas requiring pressure washing for street furniture and sidewalks and report to the jurisdiction.
 - g. Vandalized or damaged benches, shelters, or other objects.
 - h. Tree branch(es) extending over the sidewalk/boarding area, less than seven (7) feet above grade.
 - i. Large oversized items, trash, or debris. Photograph large items and report to the jurisdiction.

Note: If any safety issues or hazards are found, all necessary measures will be taken to minimize or eliminate the potential risks to the public. If required, the local jurisdiction and/or property owner(s) will be notified as soon as possible. Notification will be made via e-mail or fax, and a copy of the transmittal will be forwarded to OCTA.

- 7) Inspect the roadway on both the approach and departure side of the bus zone for roadway damage, safety issues, or hazards that could potentially damage a bus pulling into or out of the bus zone. Hazards could include, but are not limited to the following:
 - a. Potholes or uneven roadway surfaces.
 - b. Cracked or broken sections of the curb/gutter along the length of the bus zone.
 - c. Uneven surfaces, cracked, broken, or other damages to utility boxes or vaults (i.e. storm drains, manholes, underground electrical vaults, etc.)
 - d. Tree branches extending into the street less than 14 feet above the roadway.

Note: If any safety issues or hazards are found, all necessary measures will be taken to minimize or eliminate the potential risks to the public. If required, the local jurisdiction and/or property owner(s) will be notified as soon as possible. Notification will be made via e-mail or fax, and a copy of the transmittal will be forwarded to OCTA.

- 8) Empty all jurisdiction and/or privately-owned trash receptacles located at each bus stop. Remove all loose trash, debris, or other items that may be lodged at the bottom of each trash receptacle. Place a new trash bag, secure it to the rim of the trash receptacle.

Documentation of Task 2 Maintenance:

All work performed while performing "Preventive Maintenance" will be clearly documented and if follow-up work is required, the appropriate agency(ies) and/or property owner(s) will be notified within twenty-four (24) hours of servicing the bus stop(s). The person performing the maintenance will sign their name at the bottom of each route page and note the date the work was completed.

All documentation will be legible, written in English, and maintained at the Contractor's place of business. Upon request, the Contractor will provide OCTA with any or all documentation associated with the "City Assistance Program".

Task 3 - Maintenance Work Orders:

Miscellaneous work orders are issued on an "as-needed" basis and can cover a variety of issues from removing graffiti, replacing damaged signs/posts, trimming trees, painting, moving benches, repairing solar lights, etc. Should the Contractor observe a condition such as an inoperative solar light or knockdown at a bus stop that warrants the need for a work order, the Contractor is required to contact OCTA with work order requests via phone or email to obtain authorization for all work performed.

Along with the miscellaneous work orders, the Contractor will receive work orders associated with OCTA's service changes. Based on the task, each work order will need to be completed prior to, or just after the effective Service Change date.

The Contractor can also expect to be issued "emergency" or "priority" work orders when a hazardous condition has developed at a bus stop and immediate attention is required. Upon receiving notification (via work order and/or phone call), the Contractor will respond and be on site within two (2) hours and take "all" necessary measures to minimize or eliminate any and all hazard(s).

Note: As noted previously, the Contractor is required to maintain an emergency telephone number and be on-call twenty-four (24) hours a day, seven (7) days per week, in the event a hazardous situation occurs after normal business hours.

Upon receiving a work order(s), the Contractor will date stamp each one and schedule the required work based on the assigned "priority" number. The "priority" numbers range from 1 to 3 and are determined by the type of work required and when the work will be completed.

Priority 1 - Work orders will be completed within twenty-four (24) hours.

Exceptions:

If Dig-Alert needs to be contacted prior to starting the work, the Contractor will notify them by dialing 811 within twenty-four (24) hours of receiving the work order(s). Forty-eight (48) hours after notifying Dig-Alert, the work order(s) will be completed.

Note: After notifying Dig-Alert, the Contractor will note the date called, the person who made the call, and the reference number on each work order.

During a service change, several hundred work orders may be issued and assigned with a "Priority 1" number. Due to the volume of work, the twenty-four (24)-hour completion deadline will not be enforced. Instead, the Contractor will have the flexibility of completing these work orders between the time they received them up to twenty-four (24) hours prior to the start of the service change.

Priority 2 - Work order will be completed within three (3) working days.

Priority 3 - Work order will be completed within five (5) working days.

Work Order Tasks:

A work order could be issued for one or more of the following tasks:

Task 3.10 - Install New Bus Stop Sign:

Work Description: Remove existing city sign(s) from post, install informational signage, place square sign cap or side mount bracket, secure bus stop sign, and reattach city sign(s) (see Attachment 9). If needed, place 10-foot post, 12-foot post or post extension, if 7-foot vertical clearance cannot be maintained, or attach side mount bracket to light standard using steel banding and secure bus stop sign (see Attachments 18-21). Reposition city signage as needed.

Note: Informational signage may include placing one (1) to four (4) informational cassettes, up to two (2) transit tubes, and appropriate mounting hardware.

Seven (7) foot height clearance is not required when sign post is located in areas not designed for pedestrian movements and/or activities (i.e. grass areas between curb and sidewalk, behind a sidewalk, in a tree well, etc.).

Task 3.11 - Remove Existing Bus Stop Sign:

Work Description: Remove bus stop sign, square sign cap or side mount bracket, informational signage, and reposition city sign(s) to top of sign post.

Note: Informational signage may include up to four (4) informational cassettes, two (2) transit tubes, and appropriate mounting hardware.

If passenger amenities (i.e. bench(es), shelter(s), trash receptacles, etc.) remain at the existing location, notify local jurisdiction, private property owner, bench and/or shelter company within twenty-four (24) hours of removing the bus stop.

Task 3.12 - Relocate Bus Stop Sign (Existing Bus Zone):

Work Description: The required work is similar to that described in Task 3.10 (install new sign) and Task 3.11 (remove existing sign).

Task 3.13 - Relocate Bus Stop Sign (New Location):

Work Description: The required work is similar to that described in Task 3.10 (install new sign) and Task 3.11 (remove existing sign) except it will require traveling to a secondary location.

Note: If passenger amenities (i.e. bench(es), shelter(s), trash receptacles, etc.) remain at the existing location, notify local jurisdiction, private property owner, bench and/or shelter company within twenty-four (24) hours of relocating the bus stop.

Task 3.14 - Replace Damaged or Missing Bus Stop Signs:

Work Description: If needed remove vandalized or damaged bus stop sign from square sign cap or side mount bracket and replace with new sign. If missing replace sign cap, side mount bracket, or other hardware if needed.

Task 3.15 - Place "No Parking" (R26) Signs:

Work Description: Mount "No Parking" (R26) sign on existing post (see Attachment 9) directly below bottom edge of bus stop sign, reposition miscellaneous signage, and if needed, place 10-foot post, 12-foot post or post extension to ensure 7-foot vertical clearance. If 7-foot vertical clearance cannot be maintained, attach "No Parking" (R26) sign to light standard, using steel banding and two (2) flared brackets, directly below the bus stop sign. Reposition city signage as needed.

Note: Seven (7) foot height clearance is not required when sign post is located in areas not designed for pedestrian movements and/or activities (i.e. grass areas between curb and sidewalk, behind a sidewalk, in a tree well, etc.)

Task 3.16 - Place Type I "Bus Exempt" Signs:

Work Description: Lower existing "Right Lane Must Turn Right" (R18) sign approximately six (6) inches down from top of post, reposition miscellaneous signage if needed, and secure a Type I "Bus Exempt" sign (see Attachment 16) above R18 sign. Place 10-foot post, 12-foot post or post extension to ensure 7-foot vertical clearance. If 7-foot vertical clearance cannot be maintained, attach Type I "Bus Exempt" sign to light standard, using steel banding and two (2) flared brackets, directly above the "Right Lane Must Turn Right" (R18) sign. Reposition miscellaneous signage as needed.

Note: At most intersections, a "Right Lane Must Turn Right" (R18) sign will be located at the beginning of the right turn pocket and at the curb return. A Type I "Bus Exempt" sign will be top mounted on all R18 signs, unless directed otherwise.

Seven (7) foot height clearance is not required when sign post is located in areas not designed for pedestrian movements and/or activities (i.e. grass areas between curb and sidewalk, behind a sidewalk, in a tree well, etc.)

Task 3.17 - Place Type II "Bus Exempt" Signs:

Work Description: Mount Type II "Bus Exempt" sign (see Attachment 17) just below the existing "Right Lane Turn Only" (R41) sign, and reposition miscellaneous signage as needed. Place 10-foot post, 12-foot post or post extension when 7-foot vertical clearance cannot be maintained.

Attach Type II "Bus Exempt" sign to light standard, using steel banding and two (2) flared brackets, directly below the "Right Lane Turn Only" (R41) sign. Reposition city signage as needed.

Note: At most intersections, a "Right Lane Turn Only" (R41) sign will be located at the beginning of the right turn pocket and at the curb return. A Type II "Bus Exempt" sign will be top mounted on all R41 signs, unless directed otherwise.

Seven (7) foot height clearance is not required when sign post is located in areas not designed for pedestrian movements and/or activities (i.e. grass areas between curb and sidewalk, behind a sidewalk, in a tree well, etc.)

Task 3.18 - Place or Remove Miscellaneous Informational/Directional Signs:

Work Description: Center mount informational or directional signage directly above or below the bus stop sign on the existing post or light standard. Place 10-foot post, 12-foot post or post extension, if 7-foot vertical clearance cannot be maintained, or attach informational or directional signage to light standard with steel banding and two (2) flare brackets. Reposition miscellaneous signage as needed (see Attachments 9 and 18).

Note: Seven (7) foot height clearance is not required when sign post is located in areas not designed for pedestrian movements and/or activities (i.e. grass areas between curb and sidewalk, behind a sidewalk, in a tree well, etc.)

Task 3.19 - Install New Bus Stop Sign and Post (Soft Surface):

Work Description: Drive down both a 30-inch post anchor and 18-inch anchor sleeve into the ground twenty-six (26) inches so they extend approximately four (4) inches above grade (see Attachment 8). Top or side-mount new bus stop sign and attach miscellaneous hardware to either an 8-foot, 10-foot or 12-foot square post. Slide post into anchor/sleeve and secure (see Attachment 7).

Miscellaneous hardware may include up to four (4) informational cassettes, two (2) transit tubes, a solar light, and appropriate mounting hardware (see Attachments 12-15).

Note: When installing a sign post, the Contractor will notify Dig-Alert at least forty-eight (48) hours prior to installing the new post. It is highly recommended that the Contractor also probe the general area before installing the sign post to avoid hitting sprinkler lines or other utilities not identified by Dig-Alert.

Task 3.20 - Install New Bus Stop Sign and Post (Firm Surface):

Work Description: Drill three (3) inch diameter hole into concrete or asphalt concrete surface, place 30-inch post anchor into hole and drive down approximately 26 inches (see Attachment 8). Top or side-mount new bus stop sign and attach miscellaneous hardware to either an 8-foot, 10-foot or 12-foot square post. Slide post into anchor/sleeve and secure (see Attachment 7).

Sweep and properly dispose of debris generated from drilling. Patch hole around anchor with plastic mortar mix and broom finish.

Miscellaneous hardware may include up to four (4) informational cassettes, two (2) transit tubes, a solar light, and appropriate mounting hardware (see Attachments 12-15).

Note: When installing a sign post, the Contractor will notify Dig-Alert at least forty-eight (48) hours prior to installing the new post. It is highly recommended that the Contractor also probe the general area before installing the sign post to avoid hitting sprinkler lines or other utilities not identified by Dig-Alert.

Task 3.21 - Remove Bus Stop Sign and Post (Soft or Firm Surface):

Work Description: Pull out sign post, anchor, and sleeve then remove all miscellaneous hardware attached to the sign post. Fill in or patch the remaining hole. If passenger amenities (i.e. bench(es), shelter(s), trash receptacles, etc.) remain at existing location, notify local jurisdiction, private property owner, bench and/or shelter company within twenty-four (24) hours of relocating the bus stop.

Note: Under no circumstances will the Contractor ever leave a location without removing the post anchor/sleeve, or without properly filling in or patching the hole created by the post anchor. The post anchor/sleeve will not be driven downward below the surface to keep from properly removing them, nor will a "No Parking" (R26) or other sign be placed on the post to avoid removing it as required.

Task 3.22 - Relocate Bus Stop Sign and Square Post (Existing Bus Zone):

Work Description: Drive a new 30-inch post anchor and 18-inch anchor sleeve down approximately twenty-six (26) inches or four (4) inches above grade. Remove square post and anchor/sleeve from old location and insert the existing post into the new anchor/sleeve and secure.

Sweep and properly dispose of debris generated from drilling. Patch hole around anchor with plastic mortar mix and broom finish.

Note: When installing a sign post, the Contractor will notify Dig-Alert at least forty-eight (48) hours prior to installing the new post. It is highly recommended that the Contractor also probe the general area before installing the sign post to avoid hitting sprinkler lines or other utilities not identified by Dig-Alert.

Task 3.23 - Relocate Bus Stop Sign to Square Post (Existing Bus Zone):

Work Description: Drive new 30-inch anchor and 18-inch sleeve down approximately twenty-six (26) inches or four (4) inches above grade. Remove all miscellaneous hardware mounted on the non-standard sign post (u-channel, wood, round, or light standard) and attach it to the new 8-foot, 10-foot or 12-foot square post. Slide post into anchor/sleeve and secure.

Remove non-standard sign post, patch remaining hole, and around new anchor with plastic mortar mix and broom finish. Sweep and properly dispose of debris generated from drilling.

Miscellaneous hardware may include from one (1) to four (4) informational cassettes, up to two (2) transit tubes, a solar light, and appropriate mounting hardware.

Note: When installing a sign post, the Contractor will notify Dig-Alert at least forty-eight (48) hours prior to installing the new post. It is highly recommended that the Contractor also probe the general area before installing the sign post to avoid hitting sprinkler lines or other utilities not identified by Dig-Alert.

Task 3.24 - Relocate Bus Stop Sign and Post (New Location):

Work Description: The work required to complete this task is similar to the work described in both Tasks 3.19 and Tasks 3.20, except it requires servicing a secondary location.

If passenger amenities (i.e. bench(es), shelter(s), trash receptacles, etc.) remain at existing location, notify local jurisdiction, private property owner, bench and/or shelter company within twenty-four (24) hours of relocating the bus stop.

Note: When installing a sign post, the Contractor will notify Dig-Alert at least forty-eight (48) hours prior to installing the new post. It is highly recommended that the Contractor also probe the general area before installing the sign post to avoid hitting sprinkler lines or other utilities not identified by Dig-Alert.

Task 3.25 - Replace Damaged Sign Post:

Work Description: Slide damaged post out of anchor and remove all hardware attached to post. Top or side-mount bus stop sign to the new post, attach miscellaneous hardware, then slide post into anchor and secure.

Depending on the extent of damage, other hardware or mounting brackets may need to be replaced.

Task 3.26 - Place Permanent or Temporary Cassette Insert:

Work Description: Remove end plate from cassette, slide old insert out, replace with new insert, and secure end plate.

Task 3.27 - Replace Damaged Cassette Lexan Shield:

Work Description: Remove end plate from cassette and slide out old Lexan shield. Insert a new shield, cassette insert, and reattach end plate.

Place a temporary insert if the original insert has been damaged. With a thick black marker, write the stop ID number, route number(s) and direction(s), on the insert, place inside cassette, and secure end plate.

Task 3.28 - Place or Replace Single Informational Cassette:

Work Description: Mount new cassette on existing sign post or attach two (2) flare shape brackets to light standard using steel banding.

Note: All cassettes will be mounted between forty-two (42) and sixty (60) inches above the sidewalk, unless directed otherwise (see Attachment 7).

Task 3.29 - Place or Remove Dual Informational Cassettes:

Work Description: Remove or loosen existing cassette and attach second cassette on back side of the sign post or mount in a side-by-side position (facing towards oncoming traffic) using special bracket (see Attachment 12).

If mounting on light standard, remove existing cassette, steel banding, and mounting brackets. Reinstall steel banding with four (4) flare brackets and attach both cassettes.

Note: Side-by-Side cassettes will only be placed when the post is located in an area not designed for pedestrian movements and/or activities (i.e. grass areas between curb and sidewalk, behind a sidewalk, in a tree well, etc.).

Task 3.30 - Place or Remove Three or Four-Sided Rotating Cassette Brackets:

Work Description: Remove the bus stop sign and all miscellaneous signage, the sign cap, and existing cassette brackets or transit tube. Mount the new three or four-sided cassette bracket and attach the new cassettes to them. Replace sign cap, bus stop sign, or other miscellaneous signs (see Attachment 13).

Task 3.31 - Place or Remove Single Transit Tube:

Work Description: Remove the bus stop sign and any miscellaneous signage, sign cap, and existing cassette brackets. Mount the new transit tube in the middle of the sign post and insert a 17.5" x 24" informational schedule inside the transit tube and secure. Replace sign cap, bus stop sign, or other miscellaneous signs (see Attachment 14).

Task 3.32 - Place or Remove Dual Transit Tubes:

Work Description: Remove the bus stop sign or miscellaneous signage, sign cap, and the existing transit tube. Attach tubular mounting brackets on opposite sides of sign post (parallel to roadway), attach a transit tube to each bracket, insert a 17.5" x 24" informational schedule inside each tube and secure top section of the brackets.

Replace sign cap, bus stop sign, or other signs that were removed (see Attachment 15).

Task 3.33 - Place Solar Lighting Unit (Standard Down Light Position):

Work Description: Remove all hardware from the existing post and replace the post if it is less than 10 feet high. Insert the wire harness down the center of the post and connect to the "push button" assembly mounted directly below the cassette or transit tube. Connect the opposite end of the harness to the "head" assembly and secure the unit to the top of the post. Test both the flashing "bus signal" and "down light" to ensure they are operational.

Place a side-mount bracket on the right side of sign post below the "head" assembly and attach bus stop sign. Place any miscellaneous signage or other hardware that was removed prior to placing the solar light (see Attachment 10).

Note: When installing a solar lighting unit always record the serial numbers for both the "head" and "push button" assemblies.

The "head" assembly is usually mounted on the post so the "down light" is facing away from the street and onto the sidewalk. No matter what position the "down light" is in, the flashing "bus signal" will "always" face towards oncoming traffic.

Task 3.34 - Place Solar Lighting Unit (Modified Down Light Position):

Work Description: Loosen the top section of "head" assembly and rotated "down light" 90 to 180 degrees, then secure to the main housing unit (the "bus signal" will not be rotated, and will "always" remain in the standard position facing towards oncoming traffic)

Remove all hardware from the existing post and replace the post if it is less than ten (10) feet high. Insert the wire harness down the center of the post and connect to the "push button" assembly mounted directly below the cassette or transit tube. Connect the opposite end of the harness to the "head" assembly and secure the unit to the top of the post. Test both the flashing "bus signal" and "down light" to ensure they are operational.

Place a side-mount bracket on the right side of the side post just below the "head" assembly and attach the bus stop sign (see Attachment 11). Also, place any miscellaneous signage of other hardware that was removed prior to placing the solar light.

Note: When installing a solar lighting unit always record the serial numbers for both the "head" and "push button" assemblies.

Task 3.35 - Remove Solar Lighting Unit:

Work Description: Remove all signage and mounting hardware from the post. Remove solar light "head" assembly and disconnect the wire harness. Remove the "push button" assembly mounted below the cassette or transit tube and disconnect and pull out the harness through the post.

If needed, replace the 10-foot post with a new 8-foot post. Secure any cassette brackets or transit tubes to the post, place a sign cap on top of the post, then fasten the bus stop sign. Remount any miscellaneous signs as needed.

Note: When removing a solar lighting unit, always record the serial numbers for both the "head" and "push button" assemblies.

Task 3.36 - Relocate Solar Lighting Unit:

Work Description: The required work is similar to that described in Task 3.32 (Placing a Solar Light) and Task 3.34 (Removing a Solar Light), except it will require traveling to a secondary location.

Note: When relocating a solar lighting unit always record the serial numbers for both the "head" and "push button" assemblies.

Task 3.37 - Replace Solar Light Head Assembly:

Work Description: Remove the "head" assembly, disconnect the wire harness, and attach it to a new housing unit then secure to sign post.

Test both the flashing "bus signal" and "down light" to ensure they are operational.

Note: When replacing a "head" assembly always record the serial numbers for both the old and new units.

Task 3.38 - Repair or Replace Solar Light Push Button Assembly:

Work Description: Remove the "push button" assembly, inspect the circuit board connections, and replace wiring if needed. If repairs cannot be made, disconnect the wire harness and attach a new "push button" assembly then secure to sign post.

Test both the flashing "bus signal" and "down light" to ensure they are operational.

Note: When replacing a "head" assembly always record the serial numbers for both the old and new units.

Task 3.39 - Replace Solar Light Wire Harness:

Work Description: Remove both the "head" and "push button" assemblies from the sign post and disconnect the wire harness from each unit. Remove old wiring and insert new harness through the center of the post. Reconnect new wire harness to both the "push button" and "head" assemblies and remount unit to sign post.

Test both the flashing "bus signal" and "down light" to ensure they are operational.

Task 3.40 - Relocate Metal or Wrought Iron Trash Receptacle (Existing Bus Zone):

Work Description: Relocate a city or privately-owned trash receptacle (weighing between 100 to 350 pounds) from the current location and shift it to a new position within the existing bus zone (see Attachments 4-6). One or more holes may need to be drilled into the sidewalk for anchor bolts to secure the trash receptacle. All anchor bolts at the old location will either be removed or cut off flush with the adjoining sidewalk.

Task 3.41 - Relocate Metal or Wrought Iron Trash Receptacle (New Bus Zone):

Work Description: The required work will require traveling to a secondary location to install the trash receptacle. All anchor bolts will either be removed or cut off flush with the adjoining sidewalk prior to leaving the location.

Any trash and debris remaining in and around the existing bus zone will be picked up and disposed of prior to moving to the new location.

Task 3.42 - Relocate Concrete Trash Receptacle(s):

Work Description: Relocate a city or privately-owned trash receptacle (weighing between 250 to 350 pounds) from the current location and moved to a new position within the existing bus zone (see Attachments 4-6).

Task 3.43 - Relocate Metal or Wrought Iron Bench(es) (Existing Bus Stop):

Work Description: Relocate a city or privately-owned bench (weighing between 150 and 350 pounds) from the current location and moved to a new position within the existing bus zone. Several holes may need to be drilled into the sidewalk for anchor bolts to secure each bench. All anchor bolts at the old location will either be removed or cut off flush with the adjoining sidewalk.

Task 3.44 - Relocate Metal or Wrought Iron Bench(es) (New Bus Stop):

Work Description: The required work will require traveling to a secondary location to install the bus bench.

All anchor bolts will either be removed or cut off flush with the adjoining sidewalk prior to leaving the location.

Task 3.45 - Relocate City Concrete Bench(es) (Existing Bus Stop):

Work Description: City or privately owned concrete benches (weighing between 250 and 600 pounds) will be shifted or relocated to a new area within the existing bus zone.

Task 3.46 - Remove Graffiti:

Work Description: Remove all graffiti or unauthorized items attached to the bus stop sign, sign post, display case, cassette, cassette shield, transit tube, or other signs affixed to OCTA's sign post. To include, but not limited to: paint, ink markings, decals, stickers, campaign signs, garage sale signs, etc.

Task 3.47 - Empty Trash Receptacle(s):

Work Description: Empty trash receptacle(s) as needed. Remove any loose trash or particles that settled at the bottom of the receptacle. Pick up and remove all trash and debris lying on the ground around the trash receptacle. Place a new trash bag and secure it to the top rim of receptacle.

Task 3.48 - Trim Tree(s) and Bushes:

Work Description: Trim trees or other vegetation blocking or obstructing the bus zone, passenger boarding area, sidewalk, bus stop sign, informational signs, benches or shelters (see Attachment 22). Pick up trimmings and sweep off the sidewalk.

Task 3.49 - Remove Weeds:

Work Description: Remove all weeds growing between the curb and adjoining sidewalk, along sidewalk expansion joints, behind the sidewalk, and under benches and shelters. Pick up weeds and sweep off the sidewalk.

Task 3.50 - General Bus Stop Maintenance:

Work Description: Perform general maintenance in and around the bus zone (see Attachment 3), which includes: Sweeping off the sidewalk/boarding area, removing trash or debris from the gutter, relocating news racks, removing shopping carts, removing unsanitary items or materials, wiping down dirty benches, or other miscellaneous items.

Task 3.51 - Steam Clean Passenger Boarding Area:

Work Description: Steam clean boarding area (see Attachments 4-6) to remove dirt, grime, stains, or other substances covering the sidewalk, benches, shelters, and trash receptacles. Remove any standing water from boarding area. Collect all waste water and dispose of it per existing local, county, and state ordinances.

The average area to be steam cleaned will vary from 8 feet x 25 feet (200 sq. ft.) to 8 feet x 80 feet (640 sq. ft.).

Note: Under no circumstance will waste water be poured down a storm drain.

Task 3.52 - Place Red Curb:

Work Description: Prepare curb surface. Paint or re-paint curb along the length of the bus zone using traffic red paint

The average length of curb to be painted will range between forty (40) and eighty (80) linear feet.

Note: If a paint sprayer is used, the Contractor will take reasonable precautions to protect vehicles or other property in the area.

Task 3.53 - Remove Red Curb (Gray Out):

Work Description: Prepare curb surface. Paint over the existing section of red curb using traffic gray paint. If required, a second coat of gray paint will be applied to completely cover the existing red curb.

The average length of curb to be painted will range between forty (40) and eighty (80) linear feet.

Note: If a paint sprayer is used, the Contractor will take reasonable precautions to protect vehicles or other property in the area.

Task 3.54 - Remove Red Curb (Sand-Blasting):

Work Description: Sandblast curb to remove all red paint along the length of the bus zone.

The average length of red curb to be sandblasted will range from forty (40) to eighty (80) linear feet.

Note: Safety precautions will be taken to protect both the public and maintenance crew. In addition, reasonable care will be taken to avoid any collateral damage to vehicles or other property

Task 3.55 - Field Check Miscellaneous Bus Stop Locations:

Work Description: Drive to a specific bus stop location to inspect or evaluate existing conditions at the stop.

Note: If a work order is issued for one of the tasks noted above and no identifiable maintenance problem(s) exists, or it is determined to be the wrong location, the Contractor will be permitted to invoice OCTA under this task for the cost of dispatching a service vehicle.

Task 3.56 - Miscellaneous Work Orders:

Work Description: Perform miscellaneous work or tasks not listed in the above tasks. This may include, but not limited to: placing non-standard signs and posts, relocating and removing shelters, etc.

Note: The Contractor will be permitted to invoice OCTA for time and materials used to complete this task. Under no circumstance will the Contractor charge OCTA for the cost to rent or lease equipment that is required to perform the day-to-day maintenance outlined in Tasks 1, 2, and 3 (i.e. core drill, sand blaster, compressor, steam cleaner, etc.) without prior written approval from OCTA.

Task 3.57 - Emergency Work Orders:

Work Description: Perform all maintenance required to minimize or eliminate any hazardous or dangerous situation that has developed at a bus stop after normal working hours.

Upon receiving notification (via work order and/or phone call), the Contractor will respond and be on site within two (2) hours.

Documentation of Task 3 Maintenance:

After completing a work order, the Contractor will inspect the bus zone and perform any additional maintenance that may be needed. Any secondary work performed, while at the stop, will be noted on the work order.

The Contractor will also note the materials and/or hardware used to complete the work by checking the appropriate box(es) at the bottom of each work order. If the work cannot be completed for any reason, the appropriate box will be checked, and the Contractor will note what follow-up work is required. Prior to departing the stop location, the person performing the maintenance will sign the work order and enter the date the work was completed.

All notations and/or comments written on each work order will be legible and in English.

Completed work orders will be returned to OCTA within seven (7) to ten (10) working days.

Bus Zone Procedures:

- 1) Upon arriving at a bus stop, the Contractor will make every attempt to position or park the service vehicle behind the stop to allow buses full access to bus zone. If an off-street location is not available, the Contractor can park the service vehicle in the roadway, adjacent to the bus zone. When this occurs, the service vehicle should be parked on the departure side, or the far end, of the bus zone.
- 2) In the event that the service vehicle(s) is required to park in the roadway, traffic diversion devices such as cones, delineators, and/or barricades will be properly placed allowing motorists to safely maneuver around the bus zone while servicing the stop.
- 3) To ensure the safety of pedestrians in the immediate area, the Contractor may need to cordon off or place barricades around the work area prior to performing any maintenance.

Note: The Contractor may be required to close down the entire bus stop to complete an assigned task. If this situation occurs, the Contractor will cordon off the sidewalk and will place a discontinued sign over the permanent bus stop sign and place a temporary sign in a location outside the work area.

Prior to closing down any bus stop/zone, the Contractor will coordinate the closure with the Supervisor of the Stops and Zones Section or with OCTA's Field Operations Department.

Contractor's Performance:

- 1) The Contractor will complete all assigned work per OCTA's standards to ensure that each bus stop location is safe, clean, and in good condition.
- 2) The Contractor will perform and complete all assigned work in the prescript timeframes as outlined in Tasks 1, 2, and 3.
- 3) If the Contractor's conduct, performance, or work does not meet OCTA's standards, they will be notified in writing and given twenty-four (24) hours to take any required corrective action. If for any reason the Contractor is unable or unwilling to comply with the demand, OCTA may take the necessary steps to rectify the situation. Any costs incurred by OCTA may be deducted from the Contractor's monthly invoice.

If the Contractor fails to respond and does not take corrective action, OCTA may choose to terminate the contract for default.

Bus Stop Maintenance Program
Number of Stops by City

RFP 1-3408
 Exhibit A
 Attachment 1

County	City	Number of Stops
OC	Aliso Viejo	17
OC	Anaheim	561
LA	Artesia	6
OC	Brea	79
OC	Buena Park	174
LA	Cerritos	29
OC	Costa Mesa	217
OC	County Of Orange	67
OC	Cypress	78
OC	Dana Point	51
OC	Fountain Valley	142
OC	Fullerton	311
OC	Garden Grove	286
LA	Hawaiian Gardens	11
OC	Huntington Beach	377
OC	Irvine	435
OC	La Habra	78
LA	La Mirada	7
OC	La Palma	23
OC	Laguna Beach	71
OC	Laguna Hills	78
OC	Laguna Niguel	89
OC	Laguna Woods	24
OC	Lake Forest	153
LA	Lakewood	7
LA	Long Beach	37
OC	Los Alamitos	39
LA	Los Angeles	43
OC	Mission Viejo	172
OC	Newport Beach	213
OC	Orange	298
OC	Placentia	97
OC	Rancho Santa Margarita	26
RS	Riverside	1
OC	San Clemente	60
OC	San Juan Capistrano	36
OC	Santa Ana	654
OC	Seal Beach	46
OC	Stanton	51
OC	Tustin	126
OC	Villa Park	8
OC	Westminster	183
OC	Yorba Linda	19
Total Number of Bus Stops:		5480

Bus Stop Maintenance

RFP 1-3408

All Stop Locations

Exhibit A

Attachment 2

OCTA_ID	CITY	DIR	STREET_OF_TRAVEL	LOC	CROSS_STREET
1	ANA	NB	HASTER	FS	WILKEN
2	ANA	NB	HASTER	NS	ORANGEWOOD
3	ANA	NB	HASTER	FS	LEATRICE
4	ANA	NB	HASTER	VNS	KATELLA
5	ANA	NB	ANAHEIM	FS	KATELLA
6	ANA	NB	ANAHEIM	FS	CERRITOS
7	ANA	NB	ANAHEIM	FS	PALAIS
8	ANA	NB	ANAHEIM	NS	BALL
9	ANA	NB	ANAHEIM	NS	LORRAINE
10	ANA	NB	ANAHEIM	FS	VERMONT
11	ANA	NB	ANAHEIM	NS	SOUTH
12	ANA	NB	ANAHEIM	NS	WATER
13	ANA	NB	ANAHEIM	FS	SANTA ANA
14	ANA	NB	ANAHEIM	NS	BROADWAY
15	ANA	NB	ANAHEIM	OPP	CENTER STREET PROMENADE
16	ANA	NB	ANAHEIM	FS	LINCOLN
17	ANA	NB	ANAHEIM	NS	SYCAMORE
18	ANA	NB	ANAHEIM	NS	WILHELMINA
19	ANA	NB	ANAHEIM	NS	NORTH
20	ANA	SB	ANAHEIM	NS	LA VERNE
21	ANA	SB	ANAHEIM	NS	NORTH
22	ANA	SB	ANAHEIM	FS	WILHELMINA
23	ANA	SB	ANAHEIM	FS	SYCAMORE
24	ANA	SB	ANAHEIM	FS	LINCOLN
25	ANA	SB	ANAHEIM	NS	BROADWAY
26	ANA	SB	ANAHEIM	FS	SANTA ANA
27	ANA	SB	ANAHEIM	FS	WATER
28	ANA	SB	ANAHEIM	FS	SOUTH
29	ANA	SB	ANAHEIM	FS	VALENCIA
30	ANA	SB	ANAHEIM	FS	VERMONT
31	ANA	SB	ANAHEIM	OPP	LORRAINE
32	ANA	SB	ANAHEIM	FS	BALL
33	ANA	SB	ANAHEIM	FS	WINSTON
34	ANA	SB	ANAHEIM	FS	MIDWAY
35	ANA	SB	ANAHEIM	NS	CERRITOS
36	ANA	SB	HASTER	FS	KATELLA
37	ANA	SB	HASTER	OPP	WAKEFIELD
38	ANA	SB	HASTER	NS	ORANGEWOOD
39	ANA	SB	HASTER	NS	WILKEN
40	ANA	SB	HASTER	FS	TILLER
41	ANA	EB	BALL	FS	FREMONT
42	ANA	EB	BALL	FS	KNOTT
43	ANA	EB	BALL	FS	MASTERS
44	ANA	EB	BALL	FS	WESTERN
45	ANA	EB	BALL	FS	COURTRIGHT
46	ANA	EB	BALL	OPP	HALLIDAY

Bus Stop Maintenance

RFP 1-3408

All Stop Locations

Exhibit A

Attachment 2

OCTA_ID	CITY	DIR	STREET_OF_TRAVEL	LOC	CROSS_STREET
47	ANA	EB	BALL	FS	BEACH
48	ANA	EB	BALL	FS	FERN
49	ANA	EB	BALL	FS	DALE
50	ANA	EB	BALL	FS	MACDUFF
51	ANA	EB	BALL	FS	MAGNOLIA
52	ANA	EB	BALL	OPP	WEBSTER
53	ANA	EB	BALL	NS	GILBERT
54	ANA	EB	BALL	NS	BROOKHURST
55	ANA	EB	BALL	FS	EMPIRE
56	ANA	EB	BALL	FS	NUTWOOD
57	ANA	EB	BALL	OPP	TRIDENT
58	ANA	EB	BALL	FS	EUCLID
59	ANA	EB	BALL	OPP	LOARA
60	ANA	EB	BALL	OPP	HAMPSTEAD
61	ANA	EB	BALL	FS	WALNUT
62	ANA	EB	BALL	NS	WEST
63	ANA	EB	BALL	NS	CAST
64	ANA	EB	BALL	FS	HARBOR
65	ANA	EB	BALL	FS	CLAREMONT
66	ANA	EB	BALL	FS	ANAHEIM
67	ANA	EB	BALL	FS	ALLEC
68	ANA	EB	BALL	NS	LEWIS
69	ANA	EB	BALL	OPP	EAST
70	ANA	EB	BALL	NS	SHERMAN
71	ANA	EB	BALL	FS	STATE COLLEGE
72	ANA	EB	BALL	FS	BELHAVEN
73	ANA	EB	BALL	NS	SUNKIST
74	ANA	WB	BALL	FS	SUNKIST
75	ANA	WB	BALL	FS	BELHAVEN
76	ANA	WB	BALL	FS	STATE COLLEGE
77	ANA	WB	BALL	VNS	EAST
78	ANA	WB	BALL	NS	EAST
79	ANA	WB	BALL	OPP	LEWIS
80	ANA	WB	BALL	OPP	ALLEC
81	ANA	WB	BALL	NS	ANAHEIM
82	ANA	WB	BALL	NS	LEMON
83	ANA	WB	BALL	NS	HARBOR
84	ANA	WB	BALL	FS	OX
85	ANA	WB	BALL	NS	FLORE
86	ANA	WB	BALL	FS	WALNUT
87	ANA	WB	BALL	FS	HAMPSTEAD
88	ANA	WB	BALL	FS	LOARA
89	ANA	WB	BALL	FS	EUCLID
90	ANA	WB	BALL	FS	TRIDENT
91	ANA	WB	BALL	NS	NUTWOOD
92	ANA	WB	BALL	NS	EMPIRE

Bus Stop Maintenance

RFP 1-3408

All Stop Locations

Exhibit A

Attachment 2

OCTA_ID	CITY	DIR	STREET_OF_TRAVEL	LOC	CROSS_STREET
93	ANA	WB	BALL	FS	BROOKHURST
94	ANA	WB	BALL	OPP	PERDIDO
95	ANA	WB	BALL	FS	GILBERT
96	ANA	WB	BALL	NS	WEBSTER
97	ANA	WB	BALL	NS	MAGNOLIA
98	ANA	WB	BALL	FS	SHERRILL
99	ANA	WB	BALL	FS	DALE
100	ANA	WB	BALL	OPP	FERN
101	ANA	WB	BALL	FS	BEACH
102	ANA	WB	BALL	NS	HALLIDAY
103	ANA	WB	BALL	NS	WESTERN
104	ANA	WB	BALL	NS	WESTVALE
105	ANA	WB	BALL	FS	KNOTT
106	ANA	NB	BEACH	FS	BALL
107	ANA	NB	BEACH	FS	ROME
108	ANA	NB	BEACH	FS	ORANGE
109	ANA	NB	BEACH	FS	YOUTH CENTER
110	ANA	NB	BEACH	FS	LINCOLN
111	ANA	SB	BEACH	FS	LINCOLN
112	ANA	SB	BEACH	OPP	YOUTH CENTER
113	ANA	SB	BEACH	VNS	ORANGE
114	ANA	SB	BEACH	FS	ORANGE
115	ANA	SB	BEACH	OPP	ROME
116	ANA	SB	BEACH	FS	BALL
117	ANA	EB	BROADWAY	FS	ANAHEIM
118	ANA	EB	BROADWAY	FS	KROEGER
119	ANA	WB	BROADWAY	NS	ATCHISON
120	ANA	NB	BROOKHURST	FS	KATELLA
121	ANA	NB	BROOKHURST	FS	CRESTWOOD
122	ANA	NB	BROOKHURST	FS	CERRITOS
123	ANA	NB	BROOKHURST	FS	PALAIS
124	ANA	NB	BROOKHURST	FS	BALL
125	ANA	NB	BROOKHURST	FS	BROOKMORE
126	ANA	NB	BROOKHURST	FS	NIOBE
127	ANA	NB	BROOKHURST	FS	ORANGE
128	ANA	NB	BROOKHURST	NS	BROADWAY
129	ANA	NB	BROOKHURST	FS	LINCOLN
130	ANA	NB	BROOKHURST	FS	CATALINA
131	ANA	NB	BROOKHURST	NS	CRESCENT
132	ANA	NB	BROOKHURST	FS	LA PALMA
133	ANA	NB	BROOKHURST	FS	FALMOUTH
134	ANA	NB	BROOKHURST	FS	HUNTINGTON
135	ANA	SB	BROOKHURST	FS	HUNTINGTON
136	ANA	SB	BROOKHURST	NS	LA PALMA
137	ANA	SB	BROOKHURST	FS	CRESCENT
138	ANA	SB	BROOKHURST	FS	WOODLEY

Bus Stop Maintenance**All Stop Locations**

RFP 1-3408

Exhibit A

Attachment 2

OCTA_ID	CITY	DIR	STREET_OF_TRAVEL	LOC	CROSS_STREET
139	ANA	SB	BROOKHURST	FS	LINCOLN
140	ANA	SB	BROOKHURST	FS	ORANGE
141	ANA	SB	BROOKHURST	NS	STONEYBROOK
142	ANA	SB	BROOKHURST	FS	COLCHESTER
143	ANA	SB	BROOKHURST	FS	BALL
144	ANA	SB	BROOKHURST	FS	CERRITOS
145	ANA	SB	BROOKHURST	NS	PACIFIC
146	ANA	SB	BROOKHURST	FS	CRESTWOOD
147	ANA	EB	CERRITOS	NS	DISNEYLAND
148	ANA	EB	CERRITOS	FS	ANAHEIM
149	ANA	EB	CERRITOS	NS	LEWIS
150	ANA	WB	CERRITOS	FS	LEWIS
151	ANA	WB	CERRITOS	VNS	ANAHEIM
152	ANA	WB	CERRITOS	FS	WEST
153	ANA	WB	CHAPMAN	FS	SOMERSET
154	ANA	SB	CLEMENTINE	FS	FREEDMAN
155	ANA	EB	CORONADO	FS	JEFFERSON
156	ANA	EB	CORONADO	NS	VAN BUREN
157	ANA	EB	CROWTHER	NS	OXFORD
158	ANA	NB	DALE	FS	LINCOLN
159	ANA	SB	DALE	FS	CRESCENT
160	ANA	SB	DALE	FS	TYLER
161	ANA	EB	DISNEY	FS	HARBOR
162	ANA	NB	EAST	FS	BELL
163	ANA	NB	EAST	NS	VERMONT
164	ANA	NB	EAST	NS	SOUTH
165	ANA	NB	EAST	FS	SANTA ANA
166	ANA	NB	EAST	FS	LINCOLN
167	ANA	NB	EAST	NS	GLENWOOD
168	ANA	NB	EAST	NS	BELMONT
169	ANA	NB	EAST	FS	ROMNEYA
170	ANA	SB	EAST	NS	BALSAM
171	ANA	SB	EAST	FS	NORTH
172	ANA	SB	EAST	FS	SYCAMORE
173	ANA	SB	EAST	FS	SANTA ANA
174	ANA	SB	EAST	NS	SOUTH
175	ANA	SB	EAST	FS	VERMONT
176	ANA	SB	EAST	OPP	BELL
177	ANA	NB	EUCLID	FS	ORD
178	ANA	NB	EUCLID	FS	ORANGEWOOD
179	ANA	NB	EUCLID	VNS	KATELLA
180	ANA	NB	EUCLID	NS	SALLIE
181	ANA	NB	EUCLID	OPP	CRIS
182	ANA	NB	EUCLID	FS	CERRITOS
183	ANA	NB	EUCLID	FS	PALAIS
184	ANA	NB	EUCLID	FS	BALL

Bus Stop Maintenance

RFP 1-3408

All Stop Locations

Exhibit A

Attachment 2

OCTA_ID	CITY	DIR	STREET_OF_TRAVEL	LOC	CROSS_STREET
185	ANA	NB	EUCLID	FS	CRONE
186	ANA	NB	EUCLID	OPP	ORANGE
187	ANA	NB	EUCLID	FS	BROADWAY
188	ANA	NB	EUCLID	FS	PAMPAS
189	ANA	NB	EUCLID	FS	LINCOLN
190	ANA	NB	EUCLID	FS	CRESCENT
191	ANA	NB	EUCLID	OPP	GLENOAKS
192	ANA	NB	EUCLID	FS	CATHERINE
193	ANA	NB	EUCLID	FS	LA PALMA
194	ANA	NB	EUCLID	NS	ROMNEYA
195	ANA	NB	EUCLID	OPP	MEDICAL CENTER
196	ANA	SB	EUCLID	NS	MEDICAL CENTER
197	ANA	SB	EUCLID	FS	ROMNEYA
198	ANA	SB	EUCLID	NS	GLEN
199	ANA	SB	EUCLID	FS	LA PALMA
200	ANA	SB	EUCLID	NS	CATHERINE
201	ANA	SB	EUCLID	FS	GLENOAKS
202	ANA	SB	EUCLID	NS	CRESCENT
203	ANA	SB	EUCLID	FS	LINCOLN
204	ANA	SB	EUCLID	FS	BROADWAY
205	ANA	SB	EUCLID	NS	ORANGE
206	ANA	SB	EUCLID	FS	CRONE
207	ANA	SB	EUCLID	FS	BALL
208	ANA	SB	EUCLID	NS	CHALET
209	ANA	SB	EUCLID	NS	CERRITOS
210	ANA	SB	EUCLID	FS	CRIS
211	ANA	SB	EUCLID	FS	SALLIE
212	ANA	NB	HARBOR	FS	CHAPMAN
213	ANA	NB	HARBOR	FS	WILKEN
214	ANA	NB	HARBOR	FS	ORANGEWOOD
215	ANA	NB	HARBOR	FS	CONVENTION
216	ANA	NB	HARBOR	FS	KATELLA
217	ANA	NB	HARBOR	NS	FREEDMAN
218	ANA	NB	HARBOR	OPP	EAST SHUTTLE AREA
219	ANA	NB	HARBOR	FS	BALL
220	ANA	NB	HARBOR	NS	VERMONT
221	ANA	NB	HARBOR	NS	SOUTH
222	ANA	NB	HARBOR	FS	WATER
223	ANA	NB	HARBOR	FS	SANTA ANA
224	ANA	NB	HARBOR	NS	BROADWAY
225	ANA	NB	HARBOR	NS	LINCOLN
226	ANA	NB	HARBOR	FS	CHARTRES
227	ANA	NB	HARBOR	NS	SYCAMORE
228	ANA	NB	HARBOR	FS	WILHELMINA
229	ANA	NB	HARBOR	FS	NORTH
230	ANA	NB	HARBOR	FS	LA VERNE

Bus Stop Maintenance

RFP 1-3408

All Stop Locations

Exhibit A

Attachment 2

OCTA_ID	CITY	DIR	STREET_OF_TRAVEL	LOC	CROSS_STREET
231	ANA	NB	HARBOR	NS	LA PALMA
232	ANA	NB	HARBOR	FS	CARL KARCHER
233	ANA	SB	HARBOR	NS	ROMNEYA
234	ANA	SB	HARBOR	NS	LA PALMA
235	ANA	SB	HARBOR	FS	LA VERNE
236	ANA	SB	HARBOR	NS	NORTH
237	ANA	SB	HARBOR	FS	WILHELMINA
238	ANA	SB	HARBOR	NS	SYCAMORE
239	ANA	SB	HARBOR	FS	CYPRESS
240	ANA	SB	HARBOR	FS	LINCOLN
241	ANA	SB	HARBOR	FS	BROADWAY
242	ANA	SB	HARBOR	NS	SANTA ANA
243	ANA	SB	HARBOR	NS	WATER
244	ANA	SB	HARBOR	FS	SOUTH
245	ANA	SB	HARBOR	FS	VERMONT
246	ANA	SB	HARBOR	NS	BALL
247	ANA	SB	HARBOR	NS	EAST SHUTTLE AREA
248	ANA	SB	HARBOR	FS	BALL
249	ANA	SB	HARBOR	OPP	FREEDMAN
250	ANA	SB	HARBOR	FS	KATELLA
251	ANA	SB	HARBOR	FS	CONVENTION
252	ANA	SB	HARBOR	FS	ORANGEWOOD
253	ANA	SB	HARBOR	FS	WILKEN
254	ANA	NB	HOWELL	FS	KATELLA
255	ANA	EB	HOWELL	VFS	STATE COLLEGE
256	ANA	SB	HOWELL	OPP	SUNKIST
257	ANA	NB	IMPERIAL	FS	SANTA ANA CANYON
258	ANA	NB	IMPERIAL	NS	LA PALMA
259	ANA	SB	IMPERIAL	FS	LA PALMA
260	ANA	SB	IMPERIAL	NS	SANTA ANA CANYON
261	ANA	NB	JEFFERSON	FS	TUSTIN
262	ANA	EB	KATELLA	FS	EUCLID
263	ANA	EB	KATELLA	OPP	CARNELIAN
264	ANA	EB	KATELLA	NS	9TH
265	ANA	EB	KATELLA	NS	CASA VISTA
266	ANA	EB	KATELLA	FS	WEST
267	ANA	EB	KATELLA	NS	CONVENTION CENTER
268	ANA	EB	KATELLA	FS	HARBOR
269	ANA	EB	KATELLA	OPP	CLEMENTINE
270	ANA	EB	KATELLA	FS	HASTER
271	ANA	EB	KATELLA	FS	LEWIS
272	ANA	EB	KATELLA	VNS	STATE COLLEGE
273	ANA	EB	KATELLA	FS	STATE COLLEGE
274	ANA	EB	KATELLA	OPP	HOWELL
275	ANA	EB	KATELLA	FS	DOUGLASS
276	ANA	WB	KATELLA	NS	DOUGLASS

Bus Stop Maintenance

RFP 1-3408

All Stop Locations

Exhibit A

Attachment 2

OCTA_ID	CITY	DIR	STREET_OF_TRAVEL	LOC	CROSS_STREET
277	ANA	WB	KATELLA	FS	HOWELL
278	ANA	WB	KATELLA	FS	STATE COLLEGE
279	ANA	WB	KATELLA	VFS	STATE COLLEGE
280	ANA	WB	KATELLA	FS	LEWIS
281	ANA	WB	KATELLA	FS	ANAHEIM
282	ANA	WB	KATELLA	FS	CLEMENTINE
283	ANA	WB	KATELLA	FS	HARBOR
284	ANA	WB	KATELLA	OPP	CONVENTION CENTER
285	ANA	WB	KATELLA	FS	DISNEYLAND
286	ANA	WB	KATELLA	FS	WALNUT
287	ANA	WB	KATELLA	NS	9TH
288	ANA	WB	KATELLA	FS	EUCLID
289	ANA	WB	KATELLA	FS	HUMOR
290	ANA	WB	KATELLA	NS	NUTWOOD
291	ANA	WB	KATELLA	NS	DALLAS
292	ANA	WB	KATELLA	NS	BROOKHURST
293	ANA	NB	KNOTT	FS	THORNTON
294	ANA	NB	KNOTT	FS	BALL
295	ANA	NB	KNOTT	NS	ROME
296	ANA	NB	KNOTT	FS	ORANGE
297	ANA	NB	KNOTT	FS	DANBROOK
298	ANA	NB	KNOTT	FS	DEL MONTE
299	ANA	SB	KNOTT	FS	LINCOLN
300	ANA	SB	KNOTT	FS	DEL MONTE
301	ANA	SB	KNOTT	OPP	OLINDA
302	ANA	SB	KNOTT	FS	ORANGE
303	ANA	SB	KNOTT	FS	SAVANNA
304	ANA	SB	KNOTT	NS	BALL
305	ANA	SB	KNOTT	OPP	THORNTON
306	ANA	NB	KRAEMER	NS	FRONTERA
307	ANA	NB	KRAEMER	FS	LA PALMA
308	ANA	NB	KRAEMER	FS	CORONADO
309	ANA	NB	KRAEMER	FS	MIRALOMA
310	ANA	NB	KRAEMER	OPP	LA JOLLA
311	ANA	NB	KRAEMER	FS	ORANGETHORPE
312	ANA	NB	KRAEMER	NS	CROWTHER
313	ANA	SB	KRAEMER	FS	CROWTHER
314	PLAC	SB	KRAEMER	FS	ORANGETHORPE
315	ANA	SB	KRAEMER	FS	LA JOLLA
316	ANA	SB	KRAEMER	FS	MIRALOMA
317	ANA	SB	KRAEMER	FS	CORONADO
318	ANA	SB	KRAEMER	NS	LA PALMA
319	ANA	SB	KRAEMER	FS	FRONTERA
320	ANA	NB	KRAEMER PLACE	FS	LA PALMA
321	ANA	EB	LA PALMA	FS	MAGNOLIA
322	ANA	EB	LA PALMA	FS	MAYFLOWER

Bus Stop Maintenance

RFP 1-3408

All Stop Locations

Exhibit A

Attachment 2

OCTA_ID	CITY	DIR	STREET_OF_TRAVEL	LOC	CROSS_STREET
323	ANA	EB	LA PALMA	FS	GILBERT
324	ANA	EB	LA PALMA	FS	BROOKHURST
325	ANA	EB	LA PALMA	NS	FAIRVIEW
326	ANA	EB	LA PALMA	VFS	FAIRVIEW
327	ANA	EB	LA PALMA	NS	ONONDAGA
328	ANA	EB	LA PALMA	FS	EUCLID
329	ANA	EB	LA PALMA	FS	LAGUNA
330	ANA	EB	LA PALMA	FS	WEST
331	ANA	EB	LA PALMA	FS	CITRON
332	ANA	EB	LA PALMA	FS	HARBOR
333	ANA	EB	LA PALMA	FS	LEMON
334	ANA	EB	LA PALMA	NS	CLAUDINA
335	ANA	EB	LA PALMA	FS	OLIVE
336	ANA	EB	LA PALMA	NS	PAULINE
337	ANA	EB	LA PALMA	VNS	EAST
338	ANA	EB	LA PALMA	FS	EAST
339	ANA	EB	LA PALMA	NS	BUTTONWOOD
340	ANA	EB	LA PALMA	FS	ANNA
341	ANA	EB	LA PALMA	OPP	BAXTER
342	ANA	EB	LA PALMA	FS	STATE COLLEGE
343	ANA	EB	LA PALMA	NS	WHITTIER
344	ANA	EB	LA PALMA	FS	SUNKIST
345	ANA	EB	LA PALMA	NS	CHANTILLY
346	ANA	EB	LA PALMA	FS	BLUE GUM
347	ANA	EB	LA PALMA	OPP	RED GUM
348	ANA	EB	LA PALMA	FS	KRAEMER
349	ANA	EB	LA PALMA	VFS	KRAEMER
350	ANA	EB	LA PALMA	VFS	SHEPARD
351	ANA	EB	LA PALMA	FS	3RD
352	ANA	EB	LA PALMA	OPP	MILLER
353	ANA	EB	LA PALMA	NS	GROVE
354	ANA	EB	LA PALMA	FS	PACIFIC CENTER
355	ANA	EB	LA PALMA	FS	TUSTIN
356	ANA	EB	LA PALMA	OPP	HAWK
357	ANA	EB	LA PALMA	OPP	VAN BUREN
358	ANA	EB	LA PALMA	NS	RICHFIELD
359	ANA	EB	LA PALMA	FS	FEE ANA
360	ANA	EB	LA PALMA	FS	LAKEVIEW
361	ANA	EB	LA PALMA	OPP	MANASSERO
362	ANA	EB	LA PALMA	OPP	KELLOGG
363	ANA	EB	LA PALMA	OPP	BRASHER
364	ANA	EB	LA PALMA	OPP	CANYON CORPORATE CENTER
365	ANA	EB	LA PALMA	FS	IMPERIAL
366	ANA	EB	LA PALMA	OPP	EMOGENE
367	ANA	EB	LA PALMA	OPP	POTOMAC
368	ANA	EB	LA PALMA	OPP	MOSSWOOD

Bus Stop Maintenance

RFP 1-3408

All Stop Locations

Exhibit A

Attachment 2

OCTA_ID	CITY	DIR	STREET_OF_TRAVEL	LOC	CROSS_STREET
369	ANA	EB	LA PALMA	OPP	LYNWOOD
370	ANA	WB	LA PALMA	FS	YORBA LINDA
371	ANA	WB	LA PALMA	FS	JENIFER
372	ANA	WB	LA PALMA	NS	MOSSWOOD
373	ANA	WB	LA PALMA	FS	MARK
374	ANA	WB	LA PALMA	FS	POTOMAC
375	ANA	WB	LA PALMA	FS	EMOGENE
376	ANA	WB	LA PALMA	NS	HONDO
377	ANA	WB	LA PALMA	FS	ENT 5815 FRIENDLY VILLAGE
378	ANA	WB	LA PALMA	FS	IMPERIAL
379	ANA	WB	LA PALMA	FS	CANYON CORPORATE CENTER
380	ANA	WB	LA PALMA	FS	BRASHER
381	ANA	WB	LA PALMA	FS	KELLOGG
382	ANA	WB	LA PALMA	FS	MANASSERO
383	ANA	WB	LA PALMA	FS	LAKEVIEW
384	ANA	WB	LA PALMA	NS	FEE ANA
385	ANA	WB	LA PALMA	FS	RICHFIELD
386	ANA	WB	LA PALMA	FS	VAN BUREN
387	ANA	WB	LA PALMA	NS	HAWK
388	ANA	WB	LA PALMA	FS	TUSTIN
389	ANA	WB	LA PALMA	FS	FOUNTAIN
390	ANA	WB	LA PALMA	FS	MILLER
391	ANA	WB	LA PALMA	NS	OCEAN
392	ANA	WB	LA PALMA	OPP	SHEPARD
393	ANA	WB	LA PALMA	FS	KRAEMER
394	ANA	WB	LA PALMA	NS	ARMANDO
395	ANA	WB	LA PALMA	FS	RED GUM
396	ANA	WB	LA PALMA	NS	BLUE GUM
397	ANA	WB	LA PALMA	OPP	CHANTILLY
398	ANA	WB	LA PALMA	NS	MIRALOMA
399	ANA	WB	LA PALMA	FS	PARADISE
400	ANA	WB	LA PALMA	FS	WHITTIER
401	ANA	WB	LA PALMA	NS	STATE COLLEGE
402	ANA	WB	LA PALMA	FS	STATE COLLEGE
403	ANA	WB	LA PALMA	FS	BAXTER
404	ANA	WB	LA PALMA	FS	ACACIA
405	ANA	WB	LA PALMA	NS	LIBERTY
406	ANA	WB	LA PALMA	FS	EAST
407	ANA	WB	LA PALMA	NS	PAULINE
408	ANA	WB	LA PALMA	FS	OLIVE
409	ANA	WB	LA PALMA	NS	ANAHEIM
410	ANA	WB	LA PALMA	OPP	ANAHEIM
411	ANA	WB	LA PALMA	FS	LEMON
412	ANA	WB	LA PALMA	NS	HARBOR
413	ANA	WB	LA PALMA	NS	CITRON
414	ANA	WB	LA PALMA	FS	WEST

Bus Stop Maintenance

RFP 1-3408

All Stop Locations

Exhibit A

Attachment 2

OCTA_ID	CITY	DIR	STREET_OF_TRAVEL	LOC	CROSS_STREET
415	ANA	WB	LA PALMA	OPP	LIDO
416	ANA	WB	LA PALMA	FS	ARBOR
417	ANA	WB	LA PALMA	FS	EUCLID
418	ANA	WB	LA PALMA	FS	ONONDAGA
419	ANA	WB	LA PALMA	FS	ROMNEYA
420	ANA	WB	LA PALMA	NS	BROOKHURST
421	ANA	WB	LA PALMA	FS	GILBERT
422	ANA	WB	LA PALMA	OPP	MAYFLOWER
423	ANA	WB	LA PALMA	FS	MAGNOLIA
424	ANA	WB	LA PALMA	FS	WOODLAND
425	ANA	NB	LAKEVIEW	FS	MCKINNON
426	ANA	SB	LAKEVIEW	NS	LA PALMA
427	ANA	NB	LEMON	OPP	CARL KARCHER
428	ANA	NB	LEMON	FS	COMMERCIAL
429	ANA	NB	LEMON	OPP	ORANGEFAIR
430	ANA	NB	LEMON	NS	ORANGETHORPE
431	ANA	NB	LEMON	NS	FREEDOM
432	ANA	SB	LEMON	OPP	COMMERCIAL
433	ANA	SB	LEMON	FS	CARL KARCHER
434	ANA	NB	LEWIS	OPP	TILLER
435	ANA	NB	LEWIS	FS	KATELLA
436	ANA	NB	LEWIS	FS	HOWELL
437	ANA	NB	LEWIS	FS	CERRITOS
438	ANA	NB	LEWIS	VNS	BALL
439	ANA	NB	LEWIS	NS	BALL
440	ANA	SB	LEWIS	FS	BALL
441	ANA	SB	LEWIS	VFS	BALL
442	ANA	SB	LEWIS	NS	CERRITOS
443	ANA	SB	LEWIS	OPP	HOWELL
444	ANA	SB	LEWIS	FS	ORANGEWOOD
445	ANA	EB	LINCOLN	FS	KNOTT
446	ANA	EB	LINCOLN	FS	WESTCHESTER
447	ANA	EB	LINCOLN	FS	WESTERN
448	ANA	EB	LINCOLN	FS	GRAND
449	ANA	EB	LINCOLN	FS	BEACH
450	ANA	EB	LINCOLN	OPP	BEL AIR
451	ANA	EB	LINCOLN	FS	DALE
452	ANA	EB	LINCOLN	NS	STINSON
453	ANA	EB	LINCOLN	FS	MAGNOLIA
454	ANA	EB	LINCOLN	FS	GAIN
455	ANA	EB	LINCOLN	NS	GILBERT
456	ANA	EB	LINCOLN	OPP	BELINDA
457	ANA	EB	LINCOLN	FS	BROOKHURST
458	ANA	EB	LINCOLN	FS	EMPIRE
459	ANA	EB	LINCOLN	OPP	MULLER
460	ANA	EB	LINCOLN	OPP	CRESCENT

Bus Stop Maintenance

RFP 1-3408

All Stop Locations

Exhibit A

Attachment 2

OCTA_ID	CITY	DIR	STREET_OF_TRAVEL	LOC	CROSS_STREET
461	ANA	EB	LINCOLN	FS	EUCLID
462	ANA	EB	LINCOLN	FS	LOARA
463	ANA	EB	LINCOLN	FS	MANCHESTER
464	ANA	EB	LINCOLN	FS	VILLA
465	ANA	EB	LINCOLN	FS	WEST
466	ANA	EB	LINCOLN	NS	OHIO ST
467	ANA	EB	LINCOLN	NS	CITRON
468	ANA	EB	LINCOLN	FS	HARBOR
469	ANA	EB	LINCOLN	FS	CLEMENTINE
470	ANA	EB	LINCOLN	NS	ANAHEIM
471	ANA	EB	LINCOLN	FS	CLAUDINA
472	ANA	EB	LINCOLN	FS	OLIVE
473	ANA	EB	LINCOLN	FS	EAST
474	ANA	EB	LINCOLN	OPP	LA PLAZA
475	ANA	EB	LINCOLN	OPP	EVERGREEN
476	ANA	EB	LINCOLN	FS	STATE COLLEGE
477	ANA	EB	LINCOLN	FS	PEREGRINE
478	ANA	EB	LINCOLN	FS	SUNKIST
479	ANA	EB	LINCOLN	FS	RIO VISTA
480	ANA	EB	LINCOLN	NS	KINGSLEY
481	ANA	WB	LINCOLN	FS	KINGSLEY
482	ANA	WB	LINCOLN	FS	JEANINE
483	ANA	WB	LINCOLN	NS	RIO VISTA
484	ANA	WB	LINCOLN	NS	SUNKIST
485	ANA	WB	LINCOLN	OPP	PEREGRINE
486	ANA	WB	LINCOLN	FS	STATE COLLEGE
487	ANA	WB	LINCOLN	FS	EVERGREEN
488	ANA	WB	LINCOLN	FS	LA PLAZA
489	ANA	WB	LINCOLN	FS	EAST
490	ANA	WB	LINCOLN	FS	OLIVE
491	ANA	WB	LINCOLN	VNS	ANAHEIM
492	ANA	WB	LINCOLN	FS	ANAHEIM
493	ANA	WB	LINCOLN	FS	LEMON
494	ANA	WB	LINCOLN	NS	HARBOR
495	ANA	WB	LINCOLN	NS	JANSS
496	ANA	WB	LINCOLN	FS	CITRON
497	ANA	WB	LINCOLN	FS	WEST
498	ANA	WB	LINCOLN	NS	WILSHIRE
499	ANA	WB	LINCOLN	FS	MANCHESTER
500	ANA	WB	LINCOLN	FS	LOARA
501	ANA	WB	LINCOLN	FS	EUCLID
502	ANA	WB	LINCOLN	FS	CRESCENT
503	ANA	WB	LINCOLN	FS	MULLER
504	ANA	WB	LINCOLN	FS	ALADDIN
505	ANA	WB	LINCOLN	FS	BROOKHURST
506	ANA	WB	LINCOLN	VNS	BELINDA

Bus Stop Maintenance**All Stop Locations**

RFP 1-3408

Exhibit A

Attachment 2

OCTA_ID	CITY	DIR	STREET_OF_TRAVEL	LOC	CROSS_STREET
507	ANA	WB	LINCOLN	FS	GILBERT
508	ANA	WB	LINCOLN	OPP	GAIN
509	ANA	WB	LINCOLN	FS	MAGNOLIA
510	ANA	WB	LINCOLN	FS	LA REINA
511	ANA	WB	LINCOLN	FS	DALE
512	ANA	WB	LINCOLN	NS	BEL AIR
513	ANA	WB	LINCOLN	FS	BEACH
514	ANA	WB	LINCOLN	FS	GRAND
515	ANA	WB	LINCOLN	FS	WESTERN
516	ANA	WB	LINCOLN	OPP	WESTCHESTER
517	ANA	NB	MAGNOLIA	FS	WINSTON
518	ANA	NB	MAGNOLIA	NS	BALL
519	ANA	NB	MAGNOLIA	OPP	STONYBROOK
520	ANA	NB	MAGNOLIA	NS	ORANGE
521	ANA	NB	MAGNOLIA	FS	BROADWAY
522	ANA	NB	MAGNOLIA	FS	LINCOLN
523	ANA	NB	MAGNOLIA	OPP	ENT 425 COMMON
524	ANA	NB	MAGNOLIA	NS	CRESCENT
525	ANA	NB	MAGNOLIA	FS	GREENLEAF
526	ANA	NB	MAGNOLIA	NS	LA PALMA
527	ANA	NB	MAGNOLIA	FS	WOODLAND
528	ANA	NB	MAGNOLIA	FS	ENT WICKES
529	ANA	SB	MAGNOLIA	FS	ENT 1201 DELCO BATTERY CO
530	ANA	SB	MAGNOLIA	NS	WOODLAND
531	ANA	SB	MAGNOLIA	FS	LA PALMA
532	ANA	SB	MAGNOLIA	FS	GREENLEAF
533	ANA	SB	MAGNOLIA	NS	CRESCENT
534	ANA	SB	MAGNOLIA	NS	ENT 425 COMMON
535	ANA	SB	MAGNOLIA	NS	LINCOLN
536	ANA	SB	MAGNOLIA	FS	BROADWAY
537	ANA	SB	MAGNOLIA	FS	ORANGE
538	ANA	SB	MAGNOLIA	NS	STONYBROOK
539	ANA	SB	MAGNOLIA	FS	BALL
540	ANA	SB	MAGNOLIA	FS	WINSTON
541	ANA	WB	MANCHESTER	VNS	HARBOR
542	ANA	NB	MILLER	FS	LA PALMA
543	ANA	NB	MILLER	NS	ENT 1230 BOEING SPACE
544	ANA	NB	MILLER	NS	MIRALOMA
545	ANA	NB	MILLER	FS	MIRALOMA
546	ANA	NB	MILLER	OPP	ENT 1371 DATATECH
547	ANA	NB	MILLER	NS	ORANGETHORPE
548	ANA	SB	MILLER	FS	ORANGETHORPE
549	ANA	SB	MILLER	FS	ENT 1371 DATATECH
550	ANA	SB	MILLER	VFS	MIRALOMA
551	ANA	SB	MILLER	FS	ENT 1231 ANAHEIM
552	ANA	EB	MIRALOMA	FS	KRAEMER

Bus Stop Maintenance

RFP 1-3408

All Stop Locations

Exhibit A

Attachment 2

OCTA_ID	CITY	DIR	STREET_OF_TRAVEL	LOC	CROSS_STREET
553	ANA	EB	MIRALOMA	NS	8TH
554	ANA	EB	MIRALOMA	OPP	DYNAMICS
555	ANA	WB	MIRALOMA	FS	TUSTIN
556	ANA	WB	MIRALOMA	FS	MILLER
557	ANA	WB	MIRALOMA	FS	DYNAMICS
558	ANA	WB	MIRALOMA	OPP	8TH
559	ANA	EB	ORANGE	OPP	VIA VICO
560	ANA	EB	ORANGE	FS	VENADA
561	ANA	WB	ORANGE	FS	KNOTT
562	ANA	EB	ORANGETHORPE	FS	LEMON
563	ANA	EB	ORANGETHORPE	FS	ENT 400 RSI HOME
564	ANA	EB	ORANGETHORPE	OPP	ORANGETHORPE PARK
565	ANA	EB	ORANGETHORPE	FS	STATE COLLEGE
566	ANA	EB	ORANGETHORPE	NS	PLACENTIA
567	ANA	EB	ORANGETHORPE	FS	KRAEMER
568	ANA	EB	ORANGETHORPE	OPP	THAMES
569	ANA	EB	ORANGETHORPE	NS	MILLER
570	ANA	EB	ORANGETHORPE	OPP	CHAPMAN
571	ANA	EB	ORANGETHORPE	OPP	TRAUB
572	ANA	EB	ORANGETHORPE	NS	TUSTIN
573	ANA	EB	ORANGETHORPE	FS	LAKEVIEW
574	ANA	EB	ORANGETHORPE	OPP	GLENVIEW
575	ANA	EB	ORANGETHORPE	OPP	KELLOGG
576	ANA	EB	ORANGETHORPE	OPP	POST
577	ANA	EB	ORANGETHORPE	OPP	CONCERTO
578	ANA	EB	ORANGETHORPE	OPP	WILLOW WOODS
579	ANA	EB	ORANGETHORPE	NS	IMPERIAL
580	ANA	WB	ORANGETHORPE	FS	IMPERIAL
581	ANA	WB	ORANGETHORPE	VFS	VIA BREVE
582	ANA	WB	ORANGETHORPE	FS	WILLOW WOODS
583	ANA	WB	ORANGETHORPE	FS	CONCERTO
584	ANA	WB	ORANGETHORPE	NS	POST
585	ANA	WB	ORANGETHORPE	FS	KELLOGG
586	ANA	WB	ORANGETHORPE	NS	GLENVIEW
587	ANA	WB	ORANGETHORPE	FS	CROWTHER
588	ANA	WB	ORANGETHORPE	VFS	CROWTHER
589	ANA	WB	ORANGETHORPE	FS	THAMES
590	ANA	WB	ORANGETHORPE	FS	KRAEMER
591	ANA	WB	ORANGETHORPE	FS	COMMUNITY
592	ANA	WB	ORANGETHORPE	FS	RAYMOND
593	ANA	WB	ORANGETHORPE	FS	ORANGETHORPE PARK
594	ANA	WB	ORANGETHORPE	FS	ENT 301 EMPI
595	ANA	EB	ORANGEWOOD	FS	HARBOR
596	ANA	EB	ORANGEWOOD	FS	HASTER
597	ANA	EB	ORANGEWOOD	FS	MOUNTAIN VIEW
598	ANA	EB	ORANGEWOOD	FS	STATE COLLEGE

Bus Stop Maintenance

RFP 1-3408

All Stop Locations

Exhibit A

Attachment 2

OCTA_ID	CITY	DIR	STREET_OF_TRAVEL	LOC	CROSS_STREET
599	ANA	WB	ORANGEWOOD	OPP	LEWIS
600	ANA	WB	ORANGEWOOD	FS	JETTY
601	ANA	WB	ORANGEWOOD	NS	HASTER
602	ANA	WB	ORANGEWOOD	FS	HASTER
603	ANA	WB	ORANGEWOOD	FS	HARBOR
604	ANA	SB	PLACENTIA	FS	ORANGETHORPE
605	ANA	SB	RAYMOND	FS	ORANGETHORPE
606	ANA	SB	RAYMOND	FS	ORANGEFAIR
607	ANA	EB	RIVERDALE	FS	FINCH
608	ANA	EB	RIVERDALE	FS	REDROCK
609	ANA	EB	RIVERDALE	OPP	TORRENS
610	ANA	EB	RIVERDALE	FS	DEERFIELD
611	ANA	EB	RIVERDALE	NS	LAKEVIEW
612	ANA	WB	RIVERDALE	FS	LAKEVIEW
613	ANA	WB	RIVERDALE	FS	DEERFIELD
614	ANA	WB	RIVERDALE	NS	TORRENS
615	ANA	WB	RIVERDALE	OPP	REDROCK
616	ANA	WB	RIVERDALE	FS	FINCH
617	ANA	SB	ROOSEVELT	FS	SANTA ANA CANYON
618	ANA	EB	SANTA ANA CANYON	FS	LAKEVIEW
619	ANA	EB	SANTA ANA CANYON	FS	ROYAL OAK
620	ANA	EB	SANTA ANA CANYON	OPP	MAUDE
621	ANA	EB	SANTA ANA CANYON	FS	AVD MARGARITA
622	ANA	EB	SANTA ANA CANYON	FS	VIA CORTEZ
623	ANA	EB	SANTA ANA CANYON	FS	ANAHEIM HILLS
624	ANA	EB	SANTA ANA CANYON	FS	FAIRMONT
625	ANA	EB	SANTA ANA CANYON	FS	MOHLER
626	ANA	EB	SANTA ANA CANYON	NS	EUCALYPTUS
627	ANA	EB	SANTA ANA CANYON	FS	FESTIVAL CENTER
628	ANA	EB	SANTA ANA CANYON	FS	FESTIVAL
629	ANA	EB	SANTA ANA CANYON	FS	ROOSEVELT
630	ANA	WB	SANTA ANA CANYON	FS	WEIR CANYON
631	ANA	WB	SANTA ANA CANYON	FS	ROOSEVELT
632	ANA	WB	SANTA ANA CANYON	NS	EUCALYPTUS
633	ANA	WB	SANTA ANA CANYON	FS	MOHLER
634	ANA	WB	SANTA ANA CANYON	FS	FAIRMONT
635	ANA	WB	SANTA ANA CANYON	FS	ANAHEIM HILLS
636	ANA	WB	SANTA ANA CANYON	FS	VIA CORTEZ
637	ANA	WB	SANTA ANA CANYON	FS	IMPERIAL
638	ANA	WB	SANTA ANA CANYON	FS	AVD MARGARITA
639	ANA	WB	SANTA ANA CANYON	FS	MAUDE
640	ANA	WB	SANTA ANA CANYON	FS	PINNEY
641	ANA	WB	SANTA ANA CANYON	FS	WASATCH
642	ANA	NB	STADIUM VIEW	NS	SUNKIST
643	ANA	NB	STATE COLLEGE	FS	ORANGEWOOD
644	ANA	NB	STATE COLLEGE	FS	GENE AUTRY

Bus Stop Maintenance

RFP 1-3408

All Stop Locations

Exhibit A

Attachment 2

OCTA_ID	CITY	DIR	STREET_OF_TRAVEL	LOC	CROSS_STREET
645	ANA	NB	STATE COLLEGE	FS	KATELLA
646	ANA	NB	STATE COLLEGE	NS	HOWELL
647	ANA	NB	STATE COLLEGE	FS	CERRITOS
648	ANA	NB	STATE COLLEGE	NS	WINSTON
649	ANA	NB	STATE COLLEGE	FS	BALL
650	ANA	NB	STATE COLLEGE	FS	CLIFPARK
651	ANA	NB	STATE COLLEGE	FS	TURIN
652	ANA	NB	STATE COLLEGE	FS	WAGNER
653	ANA	NB	STATE COLLEGE	FS	VERMONT
654	ANA	NB	STATE COLLEGE	NS	VIKING
655	ANA	NB	STATE COLLEGE	FS	SOUTH
656	ANA	NB	STATE COLLEGE	NS	VIRGINIA
657	ANA	NB	STATE COLLEGE	FS	WESTPORT
658	ANA	NB	STATE COLLEGE	FS	LINCOLN
659	ANA	NB	STATE COLLEGE	FS	UNDERHILL
660	ANA	NB	STATE COLLEGE	OPP	REDWOOD
661	ANA	NB	STATE COLLEGE	FS	LA PALMA
662	ANA	NB	STATE COLLEGE	FS	PLACENTIA
663	ANA	NB	STATE COLLEGE	FS	VIA BURTON
664	ANA	NB	STATE COLLEGE	NS	ORANGETHORPE
665	ANA	SB	STATE COLLEGE	NS	VIA BURTON
666	ANA	SB	STATE COLLEGE	FS	ROMNEYA
667	ANA	SB	STATE COLLEGE	FS	LA PALMA
668	ANA	SB	STATE COLLEGE	FS	REDWOOD
669	ANA	SB	STATE COLLEGE	OPP	UNDERHILL
670	ANA	SB	STATE COLLEGE	FS	LINCOLN
671	ANA	SB	STATE COLLEGE	NS	SANTA ANA
672	ANA	SB	STATE COLLEGE	NS	CHELSEA
673	ANA	SB	STATE COLLEGE	FS	SOUTH
674	ANA	SB	STATE COLLEGE	NS	MORAVA
675	ANA	SB	STATE COLLEGE	FS	VERMONT
676	ANA	SB	STATE COLLEGE	FS	CORTNEY
677	ANA	SB	STATE COLLEGE	NS	CLIFPARK
678	ANA	SB	STATE COLLEGE	FS	BALL
679	ANA	SB	STATE COLLEGE	FS	WINSTON
680	ANA	SB	STATE COLLEGE	FS	CERRITOS
681	ANA	SB	STATE COLLEGE	OPP	HOWELL
682	ANA	SB	STATE COLLEGE	FS	KATELLA
683	ANA	SB	STATE COLLEGE	FS	GENE AUTRY
684	ANA	SB	STATE COLLEGE	NS	ORANGEWOOD
685	ANA	NB	TUSTIN	FS	SANTA ANA CANYON
686	ANA	NB	TUSTIN	NS	VALLEY FORGE
687	ANA	NB	TUSTIN	FS	LA PALMA
688	ANA	NB	TUSTIN	FS	JEFFERSON
689	ANA	NB	TUSTIN	FS	MIRALOMA
690	ANA	SB	TUSTIN	NS	MIRALOMA

Bus Stop Maintenance

All Stop Locations

RFP 1-3408

Exhibit A

Attachment 2

OCTA_ID	CITY	DIR	STREET_OF_TRAVEL	LOC	CROSS_STREET
691	ANA	SB	TUSTIN	NS	ENTERPRISE
692	ANA	SB	TUSTIN	NS	LA PALMA
693	ANA	SB	TUSTIN	FS	PACIFIC CENTER
694	ANA	SB	TUSTIN	FS	RIVERDALE
695	ANA	SB	TUSTIN	NS	SANTA ANA CANYON
696	ANA	NB	WALNUT	FS	KATELLA
697	ANA	NB	WALNUT	OPP	AUDRE
698	ANA	NB	WALNUT	OPP	CERRITOS
699	ANA	NB	WALNUT	OPP	GOODHUE
700	ANA	SB	WALNUT	FS	GOODHUE
701	ANA	SB	WALNUT	NS	ENT PEPPERWOOD
702	ANA	SB	WALNUT	FS	CERRITOS
703	ANA	SB	WALNUT	FS	AUDRE
704	ANA	SB	WALNUT	FS	KIMBERLY
705	ANA	NB	WEST	FS	ORANGEWOOD
706	ANA	NB	WEST	OPP	ELEANOR
707	ANA	NB	WEST	FS	KATELLA
708	ANA	NB	WEST	NS	EXIT DISNEYLAND
709	ANA	NB	WEST	OPP	CERRITOS
710	ANA	NB	WEST	FS	WINSTON
711	ANA	SB	WEST	FS	BALL
712	ANA	SB	WEST	OPP	WINSTON
713	ANA	SB	WEST	NS	CERRITOS
714	ANA	SB	WEST	FS	ENT DISNEYLAND HOTEL
715	ANA	SB	WEST	FS	KATELLA
716	ANA	SB	WEST	NS	ELEANOR
717	ANA	SB	WEIR CANYON	FS	LA PALMA
718	ANA	WB	AAS	@	MAIN ENTRANCE
719	ANA	WB	ACS	@	DOCK 1
720	ANA	WB	INTERIOR	@	DOCK 2
721	ANA	SB	INTERIOR	@	DOCK 3
722	ANA	WB	BOEING	@	BUILDING 201
723	ANA	WB	ENTRANCE	@	EMPLOYEE ENTRANCE
724	ANA	NB	INTERIOR	@	TEAM DISNEY
725	ANA	WB	INTERIOR	@	MAIN GATE
726	ANA	EB	EXPERIAN	@	MAIN ENTRANCE
727	ANA	SB	ENTRANCE	FS	MIRALOMA
728	ANA	WB	ENTRANCE	FS	LAKEVIEW
729	ANA	NB	OC SOCIAL SERVICES	@	EMPLOYEES ENTRANCE
730	ANA	EB	INTERIOR	@	FLAG POLE
731	ANA	NB	INTERIOR	@	PARKING LOT
732	ART	SB	PIONEER	FS	SOUTH
733	ART	EB	SOUTH	OPP	JERSEY
734	ART	EB	SOUTH	OPP	ELAINE
735	ART	EB	SOUTH	NS	NORWALK
736	ART	WB	SOUTH	FS	NORWALK

Bus Stop Maintenance

RFP 1-3408

All Stop Locations

Exhibit A

Attachment 2

OCTA_ID	CITY	DIR	STREET_OF_TRAVEL	LOC	CROSS_STREET
737	ART	WB	SOUTH	FS	ELAINE
738	ART	WB	SOUTH	NS	JERSEY
739	BP	EB	ARTESIA	FS	AUTO CENTER
740	BP	EB	ARTESIA	OPP	ROSTRATA
741	BP	EB	ARTESIA	FS	WESTERN
742	BP	EB	ARTESIA	NS	BEACH
743	BP	WB	ARTESIA	VFS	BEACH
744	BP	WB	ARTESIA	NS	WESTERN
745	BP	WB	ARTESIA	OPP	BOTRYOIDES
746	BP	EB	BALL	FS	VALLEY VIEW
747	BP	EB	BALL	OPP	JUANITA
748	BP	EB	BALL	FS	HOLDER
749	BP	WB	BALL	FS	YOSEMITE
750	BP	NB	BEACH	FS	COMMONWEALTH
751	BP	NB	BEACH	FS	STANTON
752	BP	NB	BEACH	FS	CRESCENT
753	BP	NB	BEACH	VFS	CRESCENT
754	BP	NB	BEACH	FS	LA PALMA
755	BP	NB	BEACH	OPP	EL CAPITAN
756	BP	NB	BEACH	FS	ORANGETHORPE
757	BP	NB	BEACH	FS	MELROSE
758	BP	NB	BEACH	FS	PINCHOT
759	BP	NB	BEACH	OPP	9TH
760	BP	NB	BEACH	FS	AUTO CENTER
761	BP	NB	BEACH	FS	ARTESIA
762	BP	NB	BEACH	FS	FRANKLIN
763	BP	NB	BEACH	FS	CASCADE
764	BP	NB	BEACH	FS	MALVERN
765	BP	NB	BEACH	NS	CAMERON
766	BP	NB	BEACH	NS	ARGYLE
767	BP	NB	BEACH	OPP	DURANGO
768	BP	SB	BEACH	FS	DURANGO
769	BP	SB	BEACH	FS	DURANGO
770	BP	SB	BEACH	NS	DURANGO
771	BP	SB	BEACH	FS	LA MIRADA
772	BP	SB	BEACH	NS	STAGE
773	BP	SB	BEACH	NS	FRANKLIN
774	BP	SB	BEACH	NS	ARTESIA
775	BP	SB	BEACH	FS	COMMONWEALTH
776	BP	SB	BEACH	FS	AUTO CENTER
777	BP	SB	BEACH	FS	9TH
778	BP	SB	BEACH	FS	10TH
779	BP	SB	BEACH	FS	MELROSE
780	BP	SB	BEACH	NS	ORANGETHORPE
781	BP	SB	BEACH	NS	EL CAPITAN
782	BP	SB	BEACH	VFS	EL CAPITAN

Bus Stop Maintenance

RFP 1-3408

All Stop Locations

Exhibit A

Attachment 2

OCTA_ID	CITY	DIR	STREET_OF_TRAVEL	LOC	CROSS_STREET
783	BP	SB	BEACH	NS	LA PALMA
784	BP	SB	BEACH	VNS	CRESCENT
785	BP	SB	BEACH	NS	CRESCENT
786	BP	SB	BEACH	OPP	STANTON
787	BP	WB	CABALLERO	NS	DESCANSO
788	BP	WB	CABALLERO	NS	VALLEY VIEW
789	BP	EB	COMMONWEALTH	FS	BEACH
790	BP	EB	COMMONWEALTH	FS	STANTON
791	BP	EB	COMMONWEALTH	FS	LOS ROBLES
792	BP	EB	COMMONWEALTH	FS	INDIANA
793	BP	EB	COMMONWEALTH	FS	DALE
794	BP	WB	COMMONWEALTH	FS	DALE
795	BP	WB	COMMONWEALTH	FS	INDIANA
796	BP	WB	COMMONWEALTH	OPP	LOS ROBLES
797	BP	WB	COMMONWEALTH	NS	MARSHALL
798	BP	WB	COMMONWEALTH	NS	HOMEWOOD
799	BP	EB	CRESCENT	FS	BEACH
800	BP	EB	CRESCENT	FS	STANTON
801	BP	EB	CRESCENT	FS	LOCUST
802	BP	WB	CRESCENT	FS	DALE
803	BP	WB	CRESCENT	FS	MERCURY
804	BP	WB	CRESCENT	NS	STANTON
805	BP	SB	DALE	NS	EAST ENT BUENA PARK
806	BP	NB	DESCANSO	OPP	DESCANSO CIRCLE
807	BP	SB	HOMEWOOD	FS	ARTESIA
808	BP	NB	KNOTT	FS	LINCOLN
809	BP	NB	KNOTT	NS	MONROE
810	BP	NB	KNOTT	FS	CRESCENT
811	BP	NB	KNOTT	OPP	HOLDER
812	BP	NB	KNOTT	FS	LA PALMA
813	BP	NB	KNOTT	OPP	THELMA
814	BP	NB	KNOTT	FS	EL VERANO
815	BP	NB	KNOTT	FS	ORANGETHORPE
816	BP	NB	KNOTT	OPP	CABALLERO
817	BP	NB	KNOTT	FS	9TH
818	BP	NB	KNOTT	FS	8TH
819	BP	NB	KNOTT	NS	VILLAGE
820	BP	NB	KNOTT	NS	ARTESIA
821	BP	SB	KNOTT	VFS	ARTESIA
822	BP	SB	KNOTT	OPP	VILLAGE
823	BP	SB	KNOTT	FS	8TH
824	BP	SB	KNOTT	OPP	9TH
825	BP	SB	KNOTT	FS	CABALLERO
826	BP	SB	KNOTT	FS	ORANGETHORPE
827	BP	SB	KNOTT	NS	BERRY
828	BP	SB	KNOTT	FS	THELMA

Bus Stop Maintenance

All Stop Locations

RFP 1-3408

Exhibit A

Attachment 2

OCTA_ID	CITY	DIR	STREET_OF_TRAVEL	LOC	CROSS_STREET
829	BP	SB	KNOTT	NS	LA PALMA
830	BP	SB	KNOTT	FS	HOLDER
831	BP	SB	KNOTT	OPP	SANTA MARTA
832	BP	SB	KNOTT	FS	CRESCENT
833	BP	SB	KNOTT	FS	YOUNGER
834	BP	SB	KNOTT	NS	MOUNT WATERMAN
835	BP	EB	LA PALMA	FS	VALLEY VIEW
836	BP	EB	LA PALMA	FS	SAN RAFAEL
837	BP	EB	LA PALMA	FS	SAN MARINO
838	BP	EB	LA PALMA	@	SAN HILARIO
839	BP	EB	LA PALMA	FS	KNOTT
840	BP	EB	LA PALMA	OPP	EL MONTE
841	BP	EB	LA PALMA	FS	WESTERN
842	BP	EB	LA PALMA	FS	BEACH
843	BP	EB	LA PALMA	FS	STANTON
844	BP	EB	LA PALMA	FS	BUENA PARK DOWNTOWN
845	BP	EB	LA PALMA	NS	DALE
846	BP	EB	LA PALMA	NS	TAMARACK
847	BP	EB	LA PALMA	FS	WOODLAND
848	BP	WB	LA PALMA	NS	BELLFLOWER
849	BP	WB	LA PALMA	NS	DALE
850	BP	WB	LA PALMA	OPP	BUENA PARK DOWNTOWN
851	BP	WB	LA PALMA	FS	STANTON
852	BP	WB	LA PALMA	FS	BEACH
853	BP	WB	LA PALMA	NS	WESTERN
854	BP	WB	LA PALMA	FS	EL MONTE
855	BP	WB	LA PALMA	FS	KNOTT
856	BP	WB	LA PALMA	OPP	SAN HILARIO
857	BP	WB	LA PALMA	FS	SAN MARINO
858	BP	WB	LA PALMA	FS	SAN RAFAEL
859	CYP	EB	LINCOLN	FS	VALLEY VIEW
860	CYP	EB	LINCOLN	OPP	HOFFMAN
861	BP	EB	LINCOLN	FS	HOLDER
862	BP	EB	LINCOLN	NS	VIA VISTA
863	BP	WB	LINCOLN	FS	KNOTT
864	BP	WB	LINCOLN	OPP	VIA VISTA
865	BP	WB	LINCOLN	FS	HOLDER
866	BP	WB	LINCOLN	NS	HOFFMAN
867	BP	WB	LINCOLN	FS	VALLEY VIEW
868	BP	WB	LINCOLN	NS	LOS ALTOS
869	FULL	SB	MAGNOLIA	FS	VALENCIA
870	BP	SB	MAGNOLIA	OPP	OLIVE
871	BP	WB	AUTO CENTER	FS	BEACH
872	BP	WB	AUTO CENTER	VFS	BEACH
873	BP	EB	ORANGE	FS	HOLDER
874	BP	WB	ORANGE	FS	VIA VICO

Bus Stop Maintenance

RFP 1-3408

All Stop Locations

Exhibit A

Attachment 2

OCTA_ID	CITY	DIR	STREET_OF_TRAVEL	LOC	CROSS_STREET
875	BP	EB	ORANGETHORPE	FS	VALLEY VIEW
876	BP	EB	ORANGETHORPE	FS	ORIOLE
877	BP	EB	ORANGETHORPE	FS	PELICAN
878	BP	EB	ORANGETHORPE	FS	HOLDER
879	BP	EB	ORANGETHORPE	OPP	SANDBURG
880	BP	EB	ORANGETHORPE	VNS	KNOTT
881	BP	EB	ORANGETHORPE	FS	KNOTT
882	BP	EB	ORANGETHORPE	NS	MCNEIL
883	BP	EB	ORANGETHORPE	FS	WESTERN
884	BP	EB	ORANGETHORPE	FS	BEACH
885	BP	EB	ORANGETHORPE	FS	STANTON
886	BP	EB	ORANGETHORPE	NS	THOMAS
887	BP	WB	ORANGETHORPE	FS	MAGNOLIA
888	BP	WB	ORANGETHORPE	NS	AUTO CENTER
889	BP	WB	ORANGETHORPE	FS	INDIANA
890	BP	WB	ORANGETHORPE	FS	STANTON
891	BP	WB	ORANGETHORPE	FS	BEACH
892	BP	WB	ORANGETHORPE	FS	WESTERN
893	BP	WB	ORANGETHORPE	OPP	MCNEIL
894	BP	WB	ORANGETHORPE	NS	KNOTT
895	BP	WB	ORANGETHORPE	VFS	KNOTT
896	BP	WB	ORANGETHORPE	FS	SANDBURG
897	BP	WB	ORANGETHORPE	NS	ARAGON
898	BP	WB	ORANGETHORPE	FS	HERMOSA
899	BP	WB	ORANGETHORPE	NS	VALLEY VIEW
900	BP	SB	REGIO	FS	ALTURA
901	BP	SB	REGIO	NS	ENT 6363 KOMATSU
902	BP	SB	STANTON	VFS	CRESCENT
903	BP	NB	VALLEY VIEW	FS	CERRITOS
904	BP	NB	VALLEY VIEW	FS	MARIAN
905	BP	NB	VALLEY VIEW	FS	BELLE
906	BP	NB	VALLEY VIEW	FS	LINCOLN
907	BP	NB	VALLEY VIEW	OPP	LOS RANCHOS
908	BP	NB	VALLEY VIEW	FS	SAN REMO
909	BP	NB	VALLEY VIEW	FS	SAN RAFAEL
910	BP	NB	VALLEY VIEW	FS	LA PALMA
911	BP	NB	VALLEY VIEW	FS	ORANGETHORPE
912	BP	NB	VALLEY VIEW	OPP	CENTERPOINTE
913	BP	NB	VALLEY VIEW	NS	CABALLERO
914	BP	SB	VALLEY VIEW	FS	ORANGETHORPE
915	LP	SB	VALLEY VIEW	OPP	LA CANADA
916	BP	SB	VALLEY VIEW	FS	CRESCENT
917	BP	SB	VALLEY VIEW	FS	LOS RANCHOS
918	BP	SB	VALLEY VIEW	NS	LINCOLN
919	BREA	NB	ASSOCIATED	FS	IMPERIAL
920	BREA	NB	ASSOCIATED	FS	GREENBRIAR

Bus Stop Maintenance
All Stop Locations

RFP 1-3408
Exhibit A
Attachment 2

OCTA_ID	CITY	DIR	STREET_OF_TRAVEL	LOC	CROSS_STREET
921	BREA	NB	ASSOCIATED	NS	EUCALYPTUS
922	BREA	SB	ASSOCIATED	FS	BIRCH
923	BREA	SB	ASSOCIATED	NS	GREENBRIAR
924	BREA	EB	BIRCH	FS	BREA
925	BREA	EB	BIRCH	FS	FLOWER
926	BREA	EB	BIRCH	FS	POPLAR
927	BREA	EB	BIRCH	FS	RANDOLPH
928	BREA	EB	BIRCH	FS	BREA MALL
929	BREA	EB	BIRCH	FS	STATE COLLEGE
930	BREA	EB	BIRCH	FS	REDBAY
931	BREA	EB	BIRCH	FS	ASSOCIATED
932	BREA	EB	BIRCH	OPP	ASSOCIATED
933	BREA	EB	BIRCH	NS	KRAEMER
934	BREA	EB	BIRCH	FS	RANGER
935	BREA	EB	BIRCH	OPP	FLOWER HILL
936	BREA	EB	BIRCH	FS	VOYAGER
937	BREA	EB	BIRCH	NS	VALENCIA
938	BREA	WB	BIRCH	FS	VALENCIA
939	BREA	WB	BIRCH	NS	FLOWER HILL
940	BREA	WB	BIRCH	FS	STARFLOWER
941	BREA	WB	BIRCH	FS	KRAEMER
942	BREA	WB	BIRCH	NS	ASSOCIATED
943	BREA	WB	BIRCH	OPP	ASSOCIATED
944	BREA	WB	BIRCH	OPP	REDBAY
945	BREA	WB	BIRCH	FS	STATE COLLEGE
946	BREA	WB	BIRCH	FS	MARKET PLACE
947	BREA	WB	BIRCH	NS	RANDOLPH
948	BREA	WB	BIRCH	FS	POPLAR
949	BREA	WB	BIRCH	FS	FLOWER
950	BREA	NB	BREA	FS	FIR
951	BREA	NB	BREA	NS	ELM
952	BREA	NB	BREA	FS	IMPERIAL
953	BREA	NB	BREA	FS	BIRCH
954	BREA	NB	BREA	FS	ASH
955	BREA	NB	BREA	NS	CYPRESS
956	BREA	NB	BREA	FS	LAMBERT
957	BREA	NB	BREA	OPP	PEPPER TREE
958	BREA	NB	BREA	VNS	STATE COLLEGE
959	BREA	SB	BREA	FS	CENTRAL
960	BREA	SB	BREA	FS	PEPPER TREE
961	BREA	SB	BREA	FS	LAMBERT
962	BREA	SB	BREA	FS	BRACKEN
963	BREA	SB	BREA	FS	BIRCH
964	BREA	SB	BREA	FS	IMPERIAL
965	BREA	SB	BREA	FS	ELM
966	BREA	SB	BREA	FS	FIR

Bus Stop Maintenance

RFP 1-3408

All Stop Locations

Exhibit A

Attachment 2

OCTA_ID	CITY	DIR	STREET_OF_TRAVEL	LOC	CROSS_STREET
967	BREA	SB	BREA	NS	JUNIPER
968	BREA	EB	CENTRAL	NS	PALM
969	BREA	EB	CENTRAL	FS	ROSCOE
970	BREA	EB	CENTRAL	OPP	DEJUR
971	BREA	EB	CENTRAL	FS	PUENTE
972	BREA	EB	CENTRAL	OPP	STEELE
973	BREA	EB	CENTRAL	FS	BERRY
974	BREA	EB	CENTRAL	OPP	SITE
975	BREA	EB	CENTRAL	FS	TAMARACK
976	BREA	EB	CENTRAL	VNS	BREA
977	BREA	WB	CENTRAL	FS	BREA
978	BREA	WB	CENTRAL	FS	TAMARACK
979	BREA	WB	CENTRAL	NS	SITE
980	BREA	WB	CENTRAL	FS	BERRY
981	BREA	WB	CENTRAL	FS	STEELE
982	BREA	WB	CENTRAL	FS	PUENTE
983	BREA	WB	CENTRAL	FS	DEJUR
984	FULL	EB	IMPERIAL	NS	PUENTE
985	BREA	EB	IMPERIAL	FS	AROVISTA
986	BREA	EB	IMPERIAL	FS	JASMINE
987	BREA	EB	IMPERIAL	FS	BREA
988	BREA	EB	IMPERIAL	OPP	POPLAR
989	BREA	EB	IMPERIAL	NS	RANDOLPH
990	BREA	WB	IMPERIAL	FS	RANDOLPH
991	BREA	WB	IMPERIAL	FS	LAUREL
992	BREA	WB	IMPERIAL	FS	BREA
993	BREA	WB	IMPERIAL	FS	BERRY
994	BREA	WB	IMPERIAL	FS	AROVISTA
995	BREA	WB	IMPERIAL	FS	PUENTE
996	BREA	WB	IMPERIAL	NS	GEMINI
997	BREA	NB	KRAEMER	FS	SATURN
998	BREA	NB	KRAEMER	FS	IMPERIAL
999	BREA	NB	KRAEMER	NS	ORBITER
1000	BREA	NB	KRAEMER	VNS	BIRCH
1001	BREA	SB	KRAEMER	FS	BIRCH
1002	BREA	SB	KRAEMER	OPP	ORBITER
1003	BREA	SB	KRAEMER	FS	IMPERIAL
1004	BREA	SB	KRAEMER	FS	BUTTONWOOD
1005	BREA	WB	ORBITER	OPP	ENT 2830 PENNYSAVER
1006	BREA	NB	SATURN	FS	IMPERIAL
1007	BREA	NB	RANDOLPH	FS	BREA MALL
1008	BREA	SB	RANDOLPH	FS	BIRCH
1009	BREA	SB	RANDOLPH	NS	BREA MALL
1010	BREA	NB	STATE COLLEGE	FS	BREA MALL SOUTH
1011	BREA	NB	STATE COLLEGE	OPP	BREA MALL NORTH
1012	BREA	NB	STATE COLLEGE	FS	BIRCH

Bus Stop Maintenance

RFP 1-3408

All Stop Locations

Exhibit A

Attachment 2

OCTA_ID	CITY	DIR	STREET_OF_TRAVEL	LOC	CROSS_STREET
1013	BREA	NB	STATE COLLEGE	NS	AVOCADO
1014	BREA	NB	STATE COLLEGE	NS	LAMBERT
1015	BREA	SB	STATE COLLEGE	FS	LAMBERT
1016	BREA	SB	STATE COLLEGE	FS	AVOCADO
1017	BREA	SB	STATE COLLEGE	FS	BIRCH
1018	BREA	SB	STATE COLLEGE	FS	BREA MALL CENTER
1019	BREA	SB	STATE COLLEGE	NS	BREA MALL SOUTH
1020	BREA	NB	VALENCIA	NS	ELM
1021	BREA	NB	VALENCIA	NS	DATE
1022	BREA	NB	VALENCIA	FS	IMPERIAL
1023	BREA	NB	VALENCIA	FS	ENT 376 UNION OIL CO
1024	BREA	NB	VALENCIA	NS	ENT 3202 OLINDA NURSERY
1025	BREA	SB	VALENCIA	OPP	ENT 3202 OLINDA NURSERY
1026	BREA	SB	VALENCIA	FS	NASA
1027	BREA	SB	VALENCIA	NS	IMPERIAL
1028	BREA	SB	VALENCIA	FS	IMPERIAL
1029	BREA	NB	RING	NS	BREA MALL NORTH
1030	BREA	SB	RING	OPP	BREA MALL NORTH
1031	CERR	EB	183RD	NS	LOS CERRITOS CENTER
1032	CERR	EB	183RD	FS	LOS CERRITOS CENTER
1033	CERR	WB	DEL AMO	FS	MAMMOTH
1034	CERR	WB	DEL AMO	FS	BLOOMFIELD
1035	CERR	WB	DEL AMO	FS	CLARETTA
1036	CERR	WB	DEL AMO	FS	NORWALK
1037	CERR	WB	DEL AMO	FS	AVD PAMPLONA
1038	CERR	WB	DEL AMO	FS	CABRILLO
1039	CERR	NB	GRIDLEY	FS	SOUTH
1040	CERR	SB	GRIDLEY	OPP	187TH
1041	CERR	NB	PIONEER	FS	DEL AMO
1042	CERR	NB	PIONEER	FS	EBERLE
1043	CERR	NB	PIONEER	FS	195TH
1044	CERR	NB	PIONEER	NS	SOUTH
1045	CERR	SB	PIONEER	NS	195TH
1046	CERR	EB	SOUTH	FS	GRIDLEY
1047	CERR	EB	SOUTH	FS	PIONEER
1048	CERR	EB	SOUTH	FS	ELY
1049	CERR	EB	SOUTH	FS	STEFANI
1050	CERR	EB	SOUTH	FS	BLOOMFIELD
1051	CERR	EB	SOUTH	FS	ALPHINGTON
1052	CERR	EB	SOUTH	FS	VICKIE
1053	CERR	EB	SOUTH	FS	PIRES
1054	LP	EB	SOUTH	FS	CARMENITA
1055	CERR	WB	SOUTH	FS	CARMENITA
1056	CERR	WB	SOUTH	OPP	PIRES
1057	CERR	WB	SOUTH	FS	VICKIE
1058	CERR	WB	SOUTH	FS	ALFRED

Bus Stop Maintenance
All Stop Locations

RFP 1-3408
 Exhibit A
 Attachment 2

OCTA_ID	CITY	DIR	STREET_OF_TRAVEL	LOC	CROSS_STREET
1059	CERR	WB	SOUTH	FS	BLOOMFIELD
1060	CERR	WB	SOUTH	FS	STEFANI
1061	CERR	WB	SOUTH	OPP	ELY
1062	CERR	WB	SOUTH	FS	PIONEER
1063	CERR	WB	SOUTH	VNS	GRIDLEY
1064	CERR	SB	CENTER	@	ROBINSONS-MAY
1065	CERR	SB	CENTER	@	LAYOVER ZONE
1066	CM	EB	16TH	FS	PLACENTIA
1067	CM	EB	17TH	FS	PLACENTIA
1068	CM	EB	17TH	FS	POMONA
1069	CM	EB	17TH	FS	SUPERIOR
1070	CM	EB	17TH	FS	NEWPORT
1071	CM	EB	17TH	FS	ORANGE
1072	CM	EB	17TH	FS	SANTA ANA
1073	CM	EB	17TH	FS	TUSTIN
1074	CM	EB	17TH	NS	IRVINE
1075	CM	WB	17TH	FS	IRVINE
1076	CM	WB	17TH	FS	TUSTIN
1077	CM	WB	17TH	FS	SANTA ANA
1078	CM	WB	17TH	NS	ORANGE
1079	CM	WB	17TH	VNS	NEWPORT
1080	CM	WB	17TH	FS	SUPERIOR
1081	CM	WB	17TH	NS	POMONA
1082	CM	EB	18TH	FS	WALLACE
1083	CM	EB	18TH	FS	POMONA
1084	CM	EB	18TH	FS	CRESTMONT
1085	CM	EB	18TH	FS	ANAHEIM
1086	CM	WB	18TH	NS	ANAHEIM
1087	CM	WB	18TH	OPP	CRESTMONT
1088	CM	WB	18TH	FS	POMONA
1089	CM	WB	18TH	NS	WALLACE
1090	CM	EB	19TH	FS	POMONA
1091	CM	EB	19TH	FS	ANAHEIM
1092	CM	EB	19TH	FS	HARBOR
1093	CM	EB	19TH	FS	NEWPORT
1094	CM	EB	19TH	NS	ORANGE
1095	CM	WB	19TH	FS	FULLERTON
1096	CM	WB	19TH	FS	NEWPORT
1097	CM	WB	19TH	FS	HARBOR
1098	CM	WB	19TH	FS	MAPLE
1099	CM	WB	19TH	FS	MEYER
1100	CM	WB	19TH	VNS	POMONA
1101	CM	WB	19TH	FS	POMONA
1102	CM	EB	ADAMS	FS	ALBATROSS
1103	CM	EB	ADAMS	FS	PLACENTIA
1104	CM	EB	ADAMS	FS	MESA VERDE

Bus Stop Maintenance

RFP 1-3408

All Stop Locations

Exhibit A

Attachment 2

OCTA_ID	CITY	DIR	STREET_OF_TRAVEL	LOC	CROSS_STREET
1105	CM	EB	ADAMS	OPP	ROYAL PALM
1106	CM	EB	ADAMS	FS	HARBOR
1107	CM	EB	ADAMS	NS	PINECREEK
1108	CM	WB	ADAMS	FS	FAIRVIEW
1109	CM	WB	ADAMS	VFS	FAIRVIEW
1110	CM	WB	ADAMS	FS	PINECREEK
1111	CM	WB	ADAMS	NS	HARBOR
1112	CM	WB	ADAMS	FS	ROYAL PALM
1113	CM	WB	ADAMS	NS	MESA VERDE
1114	CM	WB	ADAMS	FS	MESA VERDE
1115	CM	WB	ADAMS	NS	SHANTAR
1116	CM	EB	ANTON	FS	PARK CENTER
1117	CM	WB	ANTON	FS	SAKIOKA
1118	CM	WB	ANTON	FS	AVE OF THE ARTS
1119	CM	WB	ANTON	FS	PARK CENTER
1120	CM	EB	ANTON	FS	AVE OF THE ARTS
1121	CM	SB	AVE OF THE ARTS	FS	SUNFLOWER
1122	CM	EB	BAKER	OPP	COOLIDGE
1123	CM	EB	BAKER	FS	MENDOZA
1124	CM	EB	BAKER	OPP	HYDE
1125	CM	EB	BAKER	FS	BEAR
1126	CM	EB	BAKER	NS	CENTURY
1127	CM	EB	BAKER	FS	BRISTOL
1128	CM	EB	BAKER	OPP	ENTERPRISE
1129	CM	EB	BAKER	FS	PULLMAN
1130	CM	WB	BAKER	FS	RED HILL
1131	CM	WB	BAKER	NS	ENTERPRISE
1132	CM	WB	BAKER	VFS	BRISTOL
1133	CM	WB	BAKER	NS	JEFFREY
1134	CM	WB	BAKER	FS	BEAR
1135	CM	WB	BAKER	FS	POWELL
1136	CM	WB	BAKER	NS	GRANT
1137	CM	WB	BAKER	VNS	FAIRVIEW
1138	CM	NB	BRISTOL	FS	RED HILL
1139	CM	NB	BRISTOL	NS	RANDOLPH
1140	CM	NB	BRISTOL	FS	BAKER
1141	CM	NB	BRISTOL	FS	PAULARINO
1142	CM	NB	BRISTOL	FS	ANTON
1143	CM	SB	BRISTOL	OPP	TOWN CENTER
1144	CM	SB	BRISTOL	FS	PAULARINO
1145	CM	SB	BRISTOL	NS	BAKER
1146	CM	SB	BRISTOL	FS	BAKER
1147	CM	SB	BRISTOL	FS	RANDOLPH
1148	CM	SB	BRISTOL	VFS	BEAR
1149	CM	SB	BRISTOL	FS	SOUTH ENT 1262 ACAPULCO
1150	CM	SB	COLLEGE	FS	WILSON

Bus Stop Maintenance

All Stop Locations

RFP 1-3408

Exhibit A

Attachment 2

OCTA_ID	CITY	DIR	STREET_OF_TRAVEL	LOC	CROSS_STREET
1151	CM	EB	FAIR	OPP	COLBY
1152	CM	EB	FAIR	@	VASSAR
1153	CM	EB	FAIR	@	ANDOVER
1154	CM	EB	FAIR	@	LITTLETON
1155	CM	EB	FAIR	FS	FAIRVIEW
1156	CM	EB	FAIR	NS	ENT VANGUARD
1157	CM	EB	DEL MAR	FS	NEWPORT
1158	CM	EB	DEL MAR	NS	ORANGE
1159	CM	EB	DEL MAR	NS	SANTA ANA
1160	CM	WB	DEL MAR	FS	SANTA ANA
1161	CM	WB	DEL MAR	NS	ORANGE
1162	CM	WB	DEL MAR	NS	NEWPORT
1163	CM	WB	FAIR	FS	ENT 88 ORANGE COUNTY
1164	CM	WB	FAIR	FS	FAIRVIEW
1165	CM	WB	FAIR	FS	LOYOLA
1166	CM	WB	FAIR	NS	FORDHAM
1167	CM	WB	FAIR	FS	CARNEGIE
1168	CM	NB	FAIRVIEW	FS	WILSON
1169	CM	NB	FAIRVIEW	OPP	WAKEFOREST
1170	CM	NB	FAIRVIEW	FS	YORKTOWN
1171	CM	NB	FAIRVIEW	FS	FAIR
1172	CM	NB	FAIRVIEW	OPP	MERRIMAC
1173	CM	NB	FAIRVIEW	VFS	ARLINGTON
1174	CM	NB	FAIRVIEW	NS	EL CAMINO
1175	CM	NB	FAIRVIEW	NS	BAKER
1176	CM	NB	FAIRVIEW	FS	PAULARINO
1177	CM	NB	FAIRVIEW	FS	AUGUSTA
1178	CM	NB	FAIRVIEW	FS	SOUTH COAST
1179	CM	SB	FAIRVIEW	FS	SUNFLOWER
1180	CM	SB	FAIRVIEW	VNS	SOUTH COAST
1181	CM	SB	FAIRVIEW	NS	SOUTH COAST
1182	CM	SB	FAIRVIEW	FS	BELFAST
1183	CM	SB	FAIRVIEW	OPP	PAULARINO
1184	CM	SB	FAIRVIEW	FS	BAKER
1185	CM	SB	FAIRVIEW	FS	ADAMS
1186	CM	SB	FAIRVIEW	VNS	ARLINGTON
1187	CM	SB	FAIRVIEW	NS	MERRIMAC
1188	CM	SB	FAIRVIEW	FS	FAIR
1189	CM	SB	FAIRVIEW	FS	LOYOLA
1190	CM	SB	FAIRVIEW	NS	WAKEFOREST
1191	CM	SB	FAIRVIEW	NS	WILSON
1192	CM	NB	HARBOR	NS	BERNARD
1193	CM	NB	HARBOR	NS	FORD
1194	CM	NB	HARBOR	FS	BAY
1195	CM	NB	HARBOR	FS	VICTORIA
1196	CM	NB	HARBOR	VFS	WILSON

Bus Stop Maintenance

RFP 1-3408

All Stop Locations

Exhibit A

Attachment 2

OCTA_ID	CITY	DIR	STREET_OF_TRAVEL	LOC	CROSS_STREET
1197	CM	NB	HARBOR	VFS	HARBOR CENTER
1198	CM	NB	HARBOR	NS	FAIR
1199	CM	NB	HARBOR	NS	MERRIMAC
1200	CM	NB	HARBOR	NS	PETERSON
1201	CM	NB	HARBOR	NS	ADAMS
1202	CM	NB	HARBOR	OPP	PONDEROSA
1203	CM	NB	HARBOR	NS	BAKER
1204	CM	NB	HARBOR	OPP	NUTMEG
1205	CM	NB	HARBOR	NS	GISLER
1206	CM	NB	HARBOR	FS	SOUTH COAST
1207	CM	SB	HARBOR	FS	MACARTHUR
1208	CM	SB	HARBOR	FS	SCENIC
1209	CM	SB	HARBOR	NS	SUNFLOWER
1210	CM	SB	HARBOR	FS	LAW COURT
1211	CM	SB	HARBOR	VFS	GISLER
1212	CM	SB	HARBOR	FS	NUTMEG
1213	CM	SB	HARBOR	VFS	BAKER
1214	CM	SB	HARBOR	NS	PONDEROSA
1215	CM	SB	HARBOR	FS	ADAMS
1216	CM	SB	HARBOR	NS	MESA VERDE EAST
1217	CM	SB	HARBOR	FS	MERRIMAC
1218	CM	SB	HARBOR	FS	FAIR
1219	CM	SB	HARBOR	OPP	HARBOR CENTER
1220	CM	SB	HARBOR	FS	WILSON
1221	CM	SB	HARBOR	NS	VICTORIA
1222	CM	SB	HARBOR	OPP	BAY
1223	CM	SB	HARBOR	OPP	FORD
1224	CM	SB	HARBOR	FS	19TH
1225	CM	NB	HYLAND	FS	SUNFLOWER
1226	CM	NB	HYLAND	FS	SCENIC
1227	CM	SB	HYLAND	FS	SCENIC
1228	CM	SB	HYLAND	FS	SUNFLOWER
1229	CM	SB	HYLAND	FS	ENT 3333 STATE FARM
1230	CM	EB	MACARTHUR	VNS	HYLAND
1231	CM	EB	MACARTHUR	FS	HYLAND
1232	CM	EB	MACARTHUR	OPP	CRODDY
1233	CM	SB	MAIN	FS	SUNFLOWER
1234	CM	NB	NEWPORT	FS	17TH
1235	CM	NB	NEWPORT	NS	ROCHESTER
1236	CM	NB	NEWPORT	FS	BROADWAY
1237	CM	NB	NEWPORT	FS	19TH
1238	CM	NB	NEWPORT	FS	WALNUT
1239	CM	NB	NEWPORT	NS	BAY
1240	CM	NB	NEWPORT	FS	21ST
1241	CM	NB	NEWPORT	NS	22ND
1242	CM	NB	NEWPORT	NS	23RD

Bus Stop Maintenance

RFP 1-3408

All Stop Locations

Exhibit A

Attachment 2

OCTA_ID	CITY	DIR	STREET_OF_TRAVEL	LOC	CROSS_STREET
1243	CM	NB	NEWPORT	FS	WILSON
1244	CM	NB	NEWPORT	FS	MONTE VISTA
1245	CM	SB	NEWPORT	FS	FAIR
1246	CM	SB	NEWPORT	FS	VANGUARD
1247	CM	SB	NEWPORT	FS	FAIRVIEW
1248	CM	SB	NEWPORT	FS	VICTORIA
1249	CM	SB	NEWPORT	NS	BAY
1250	CM	SB	NEWPORT	FS	FORD
1251	CM	SB	NEWPORT	FS	19TH
1252	CM	SB	NEWPORT	NS	18TH
1253	CM	NB	ORANGE	FS	15TH
1254	CM	NB	ORANGE	NS	16TH
1255	CM	NB	ORANGE	FS	OGLE
1256	CM	NB	ORANGE	NS	17TH
1257	CM	NB	ORANGE	NS	CABRILLO
1258	CM	NB	ORANGE	NS	18TH
1259	CM	NB	ORANGE	NS	BROADWAY
1260	CM	NB	ORANGE	NS	19TH
1261	CM	NB	ORANGE	NS	20TH
1262	CM	NB	ORANGE	FS	SIERKS
1263	CM	NB	ORANGE	NS	21ST
1264	CM	NB	ORANGE	NS	22ND
1265	CM	NB	ORANGE	FS	23RD
1266	CM	NB	ORANGE	FS	SANTA ISABEL
1267	CM	NB	ORANGE	FS	MONTE VISTA
1268	CM	NB	ORANGE	NS	DEL MAR
1269	CM	SB	ORANGE	NS	MONTE VISTA
1270	CM	SB	ORANGE	FS	SANTA ISABEL
1271	CM	SB	ORANGE	NS	23RD
1272	CM	SB	ORANGE	NS	22ND
1273	CM	SB	ORANGE	NS	21ST
1274	CM	SB	ORANGE	FS	BAY
1275	CM	SB	ORANGE	FS	20TH
1276	CM	SB	ORANGE	NS	19TH
1277	CM	SB	ORANGE	NS	BROADWAY
1278	CM	SB	ORANGE	FS	18TH
1279	CM	SB	ORANGE	NS	ROCHESTER
1280	CM	SB	ORANGE	FS	CABRILLO
1281	CM	SB	ORANGE	FS	17TH
1282	CM	SB	ORANGE	NS	16TH
1283	CM	SB	ORANGE	NS	15TH
1284	CM	NB	PARK	FS	18TH
1285	CM	NB	PARK	VNS	19TH
1286	CM	SB	PARK	VFS	19TH
1287	CM	EB	PAULARINO	FS	BRISTOL
1288	CM	EB	PAULARINO	FS	ENTERPRISE

Bus Stop Maintenance

RFP 1-3408

All Stop Locations

Exhibit A

Attachment 2

OCTA_ID	CITY	DIR	STREET_OF_TRAVEL	LOC	CROSS_STREET
1289	CM	WB	PAULARINO	OPP	ENTERPRISE
1290	CM	NB	PLACENTIA	FS	16TH
1291	CM	NB	PLACENTIA	FS	17TH
1292	CM	NB	PLACENTIA	NS	18TH
1293	CM	NB	PLACENTIA	NS	19TH
1294	CM	NB	PLACENTIA	NS	20TH
1295	CM	NB	PLACENTIA	NS	VICTORIA
1296	CM	SB	PLACENTIA	FS	WILSON
1297	CM	SB	PLACENTIA	FS	VICTORIA
1298	CM	SB	PLACENTIA	OPP	20TH
1299	CM	SB	PLACENTIA	FS	19TH
1300	CM	SB	PLACENTIA	FS	18TH
1301	CM	SB	PLACENTIA	FS	17TH
1302	NB	SB	PLACENTIA	FS	16TH
1303	CM	NB	POMONA	NS	17TH
1304	CM	NB	POMONA	FS	18TH
1305	CM	NB	POMONA	NS	19TH
1306	CM	NB	POMONA	OPP	20TH
1307	CM	NB	POMONA	NS	HAMILTON
1308	CM	NB	POMONA	NS	CENTER
1309	CM	SB	POMONA	FS	VICTORIA
1310	CM	SB	POMONA	FS	HAMILTON
1311	CM	SB	POMONA	FS	20TH
1312	CM	SB	POMONA	FS	19TH
1313	CM	SB	POMONA	NS	JAMES
1314	CM	NB	RED HILL	FS	BRISTOL
1315	CM	NB	RED HILL	FS	CLINTON
1316	CM	NB	RED HILL	FS	KALMUS
1317	CM	NB	RED HILL	NS	FISCHER
1318	CM	NB	RED HILL	FS	BAKER
1319	CM	NB	RED HILL	NS	PAULARINO
1320	CM	NB	RED HILL	FS	MCCORMICK
1321	CM	NB	RED HILL	FS	AIRPORT LOOP
1322	CM	SB	RED HILL	FS	PULLMAN
1323	CM	SB	RED HILL	FS	MCCORMICK
1324	CM	SB	RED HILL	FS	PAULARINO
1325	CM	SB	RED HILL	FS	BAKER
1326	CM	SB	RED HILL	FS	FISCHER
1327	CM	SB	RED HILL	FS	KALMUS
1328	CM	SB	RED HILL	OPP	CLINTON
1329	CM	SB	SANTA ANA	FS	BRISTOL
1330	CM	EB	SUNFLOWER	FS	HARBOR
1331	CM	EB	SUNFLOWER	FS	ENT 1375 LOS ANGELES
1332	CM	EB	SUNFLOWER	NS	SUSAN
1333	CM	EB	SUNFLOWER	VNS	FAIRVIEW
1334	CM	EB	SUNFLOWER	FS	FAIRVIEW

Bus Stop Maintenance

RFP 1-3408

All Stop Locations

Exhibit A

Attachment 2

OCTA_ID	CITY	DIR	STREET_OF_TRAVEL	LOC	CROSS_STREET
1335	CM	EB	SUNFLOWER	FS	WIMBLEDON
1336	CM	EB	SUNFLOWER	FS	SMALLEY
1337	CM	EB	SUNFLOWER	FS	FUCHSIA
1338	CM	EB	SUNFLOWER	NS	BEAR
1339	CM	EB	SUNFLOWER	OPP	PLAZA
1340	CM	EB	SUNFLOWER	NS	PARK CENTER
1341	CM	EB	SUNFLOWER	FS	AVE OF THE ARTS
1342	CM	EB	SUNFLOWER	FS	SAKIOKA
1343	CM	EB	SUNFLOWER	OPP	ROSS
1344	CM	EB	SUNFLOWER	OPP	TIMBER
1345	CM	WB	SUNFLOWER	FS	HARBOR
1346	CM	WB	SUNFLOWER	FS	HARBOR GATEWAY
1347	CM	SB	SUPERIOR	FS	17TH
1348	CM	EB	VICTORIA	NS	CANYON
1349	CM	EB	VICTORIA	OPP	AMERICAN
1350	CM	EB	VICTORIA	FS	NATIONAL
1351	CM	EB	VICTORIA	FS	PLACENTIA
1352	CM	EB	VICTORIA	FS	POMONA
1353	CM	EB	VICTORIA	OPP	MAPLE
1354	CM	EB	VICTORIA	FS	HARBOR
1355	CM	EB	VICTORIA	FS	THURIN
1356	CM	EB	VICTORIA	VNS	NEWPORT
1357	CM	WB	VICTORIA	FS	NEWPORT
1358	CM	WB	VICTORIA	OPP	DOCTORS
1359	CM	WB	VICTORIA	FS	COLLEGE
1360	CM	WB	VICTORIA	FS	HARBOR
1361	CM	WB	VICTORIA	NS	MAPLE
1362	CM	WB	VICTORIA	FS	POMONA
1363	CM	WB	VICTORIA	FS	PLACENTIA
1364	CM	WB	VICTORIA	FS	NATIONAL
1365	CM	WB	VICTORIA	NS	AMERICAN
1366	CM	WB	VICTORIA	FS	PACIFIC
1367	CM	EB	WILSON	FS	PLACENTIA
1368	CM	EB	WILSON	OPP	POMONA
1369	CM	EB	WILSON	FS	ANAHEIM
1370	CM	EB	WILSON	VNS	HARBOR
1371	CM	EB	WILSON	VFS	HARBOR
1372	CM	EB	WILSON	OPP	FORDHAM
1373	CM	EB	WILSON	OPP	COLGATE
1374	CM	WB	WILSON	FS	AVALON
1375	CM	WB	WILSON	FS	FORDHAM
1376	CM	WB	WILSON	OPP	COLLEGE
1377	CM	WB	WILSON	FS	HARBOR
1378	CM	WB	WILSON	NS	MAPLE
1379	CM	WB	WILSON	NS	MEYER
1380	CM	WB	WILSON	NS	POMONA

Bus Stop Maintenance

RFP 1-3408

All Stop Locations

Exhibit A

Attachment 2

OCTA_ID	CITY	DIR	STREET_OF_TRAVEL	LOC	CROSS_STREET
1381	CM	EB	ANTON	FS	SAKIOKA
1382	CM	EB	SOUTH COAST PLAZA	FS	BEAR
1383	COR	EB	GRAND	NS	MAIN
1384	COR	WB	GRAND	FS	MAIN
1385	CYP	EB	BALL	FS	BLOOMFIELD
1386	CYP	EB	BALL	FS	DELANO
1387	CYP	EB	BALL	FS	DENNI
1388	CYP	EB	BALL	FS	LARWIN
1389	CYP	EB	BALL	FS	MOODY
1390	CYP	EB	BALL	FS	SAINT CHARLES
1391	CYP	EB	BALL	FS	WALKER
1392	CYP	EB	BALL	NS	MYRA
1393	CYP	WB	BALL	FS	HOLDER
1394	CYP	WB	BALL	FS	JUANITA
1395	CYP	WB	BALL	FS	VALLEY VIEW
1396	CYP	WB	BALL	FS	CABRILLO
1397	CYP	WB	BALL	FS	WALKER
1398	CYP	WB	BALL	FS	GRINDLAY
1399	CYP	WB	BALL	FS	MOODY
1400	CYP	WB	BALL	OPP	LARWIN
1401	CYP	WB	BALL	FS	SORRENTO
1402	CYP	WB	BALL	FS	DENNI
1403	CYP	WB	BALL	NS	VIA LARGO
1404	CYP	NB	BLOOMFIELD	FS	BALL
1405	CYP	NB	BLOOMFIELD	FS	VIA INGRESSO
1406	CYP	NB	BLOOMFIELD	FS	ORANGE
1407	CYP	NB	BLOOMFIELD	FS	CARDIFF
1408	CYP	NB	BLOOMFIELD	NS	LINCOLN
1409	CYP	SB	BLOOMFIELD	FS	LINCOLN
1410	CYP	SB	HOLDER	VFS	LINCOLN
1411	CYP	SB	HOLDER	FS	LAKESHORE
1412	CYP	EB	KATELLA	FS	WARLAND
1413	CYP	EB	KATELLA	FS	VALLEY VIEW
1414	CYP	EB	KATELLA	FS	HOPE
1415	CYP	EB	KATELLA	FS	HOLDER
1416	CYP	EB	KATELLA	OPP	MERIDIAN
1417	CYP	WB	KATELLA	FS	KNOTT
1418	CYP	WB	KATELLA	FS	MERIDIAN
1419	CYP	WB	KATELLA	FS	HOLDER
1420	CYP	WB	KATELLA	FS	HOPE
1421	CYP	WB	KATELLA	FS	VALLEY VIEW
1422	CYP	WB	KATELLA	NS	DOUGLAS
1423	CYP	WB	KATELLA	FS	WALKER
1424	CYP	WB	KATELLA	NS	WINNERS CIRCLE
1425	CYP	WB	KATELLA	OPP	SIBONEY
1426	CYP	WB	KATELLA	OPP	ENTERPRISE

Bus Stop Maintenance

RFP 1-3408

All Stop Locations

Exhibit A

Attachment 2

OCTA_ID	CITY	DIR	STREET_OF_TRAVEL	LOC	CROSS_STREET
1427	CYP	SB	KNOTT	FS	CERRITOS
1428	CYP	SB	KNOTT	FS	JONATHON
1429	CYP	SB	KNOTT	FS	KATELLA
1430	CYP	SB	KNOTT	OPP	LONGFORD
1431	CYP	SB	KNOTT	FS	ORANGEWOOD
1432	CYP	SB	KNOTT	FS	LEILANI
1433	CYP	EB	LINCOLN	FS	BLOOMFIELD
1434	CYP	EB	LINCOLN	FS	LINCOLN PLAZA
1435	CYP	EB	LINCOLN	NS	DENNI
1436	CYP	EB	LINCOLN	OPP	SUMNER
1437	CYP	EB	LINCOLN	NS	MOODY
1438	CYP	EB	LINCOLN	NS	GRINDLAY
1439	CYP	EB	LINCOLN	NS	WALKER
1440	CYP	EB	LINCOLN	NS	HOME DEPOT
1441	CYP	WB	LINCOLN	FS	LOS ALTOS
1442	CYP	WB	LINCOLN	FS	WALKER
1443	CYP	WB	LINCOLN	OPP	GRINDLAY
1444	CYP	WB	LINCOLN	FS	MOODY
1445	CYP	WB	LINCOLN	FS	SUMNER
1446	CYP	WB	LINCOLN	OPP	DENNI
1447	CYP	WB	LINCOLN	OPP	LINCOLN PLAZA
1448	CYP	WB	LINCOLN	OPP	BLOOMFIELD
1449	CYP	EB	ORANGE	FS	VALLEY VIEW
1450	CYP	EB	ORANGE	FS	JUANITA
1451	CYP	WB	ORANGE	FS	HOLDER
1452	CYP	WB	ORANGE	OPP	JUANITA
1453	CYP	NB	VALLEY VIEW	FS	NOUMEA
1454	CYP	NB	VALLEY VIEW	FS	ORANGEWOOD
1455	CYP	NB	VALLEY VIEW	NS	PHYLISS
1456	CYP	NB	VALLEY VIEW	FS	KATELLA
1457	CYP	NB	VALLEY VIEW	FS	CHIP
1458	CYP	NB	VALLEY VIEW	FS	BALL
1459	CYP	NB	VALLEY VIEW	FS	FRED
1460	CYP	NB	VALLEY VIEW	FS	ORANGE
1461	CYP	NB	VALLEY VIEW	FS	LAKESHORE
1462	CYP	SB	VALLEY VIEW	FS	LAKESHORE
1463	CYP	SB	VALLEY VIEW	FS	ORANGE
1464	CYP	SB	VALLEY VIEW	OPP	FRED
1465	CYP	SB	VALLEY VIEW	FS	BALL
1466	CYP	SB	VALLEY VIEW	OPP	BELLE
1467	CYP	SB	VALLEY VIEW	NS	CATHY
1468	CYP	SB	VALLEY VIEW	NS	CERRITOS
1469	CYP	SB	VALLEY VIEW	FS	KATELLA
1470	CYP	SB	VALLEY VIEW	NS	ORANGEWOOD
1471	CYP	SB	VALLEY VIEW	FS	NOUMEA
1472	DB	NB	DIAMOND BAR	FS	PARK-N-RIDE ENTRANCE

Bus Stop Maintenance

RFP 1-3408

All Stop Locations

Exhibit A

Attachment 2

OCTA_ID	CITY	DIR	STREET_OF_TRAVEL	LOC	CROSS_STREET
1473	DB	EB	PATHFINDER	NS	BREA CANYON
1474	DB	WB	PATHFINDER	FS	FERN HOLLOW
1475	DB	NB	BREA CANYON	FS	DIAMOND BAR
1476	DB	NB	BREA CANYON	FS	COOL SPRINGS
1477	DB	NB	BREA CANYON	NS	COLD SPRINGS
1478	DB	NB	BREA CANYON	FS	FOUNTAIN SPRINGS
1479	DB	SB	BREA CANYON	OPP	FOUNTAIN SPRINGS
1480	DB	SB	BREA CANYON	NS	COLD SPRINGS
1481	DB	SB	BREA CANYON	OPP	COOL SPRINGS
1482	DB	SB	BREA CANYON	FS	DIAMOND BAR
1483	DB	WB	DIAMOND BAR	FS	BREA CANYON
1484	DP	SB	CAMINO CAPISTRANO	FS	CALLE ANEJO
1485	DP	EB	CAMINO CAPISTRANO	FS	VIA VERDE
1486	DP	EB	CAMINO CAPISTRANO	OPP	VIA CALIFORNIA
1487	DP	EB	CAMINO CAPISTRANO	OPP	VIA CATALINA
1488	DP	EB	CAMINO CAPISTRANO	NS	PALISADE
1489	DP	EB	CAMINO CAPISTRANO	FS	DOHENY
1490	DP	EB	CAMINO CAPISTRANO	OPP	CALLE HERMOSA
1491	DP	WB	CAMINO CAPISTRANO	FS	CALLE FORTUNA
1492	DP	WB	CAMINO CAPISTRANO	OPP	DOHENY
1493	DP	WB	CAMINO CAPISTRANO	NS	PALISADE
1494	DP	WB	CAMINO CAPISTRANO	FS	VIA CATALINA
1495	DP	WB	CAMINO CAPISTRANO	FS	VIA CALIFORNIA
1496	DP	WB	CAMINO CAPISTRANO	NS	VIA VERDE
1497	DP	NB	CAMINO MIRA COSTA	FS	CAPISTRANO BLUFFS
1498	DP	SB	CAMINO DE ESTRELLA	NS	AVD LAS PALMAS
1499	DP	SB	CAMINO DE ESTRELLA	FS	CALLE VERANO
1500	DP	NB	PACIFIC COAST	FS	PALISADES
1501	DP	NB	PACIFIC COAST	VNS	DEL OBISPO
1502	DP	NB	PACIFIC COAST	FS	DEL OBISPO
1503	DP	NB	PACIFIC COAST	NS	ALCAZAR
1504	DP	NB	PACIFIC COAST	NS	COLEGIO
1505	DP	NB	PACIFIC COAST	NS	VIOLET LANTERN
1506	DP	NB	PACIFIC COAST	FS	AMBER LANTERN
1507	DP	NB	PACIFIC COAST	FS	RUBY LANTERN
1508	DP	NB	PACIFIC COAST	NS	SELVA
1509	DP	NB	PACIFIC COAST	FS	NIGUEL
1510	DP	NB	PACIFIC COAST	FS	MONARCH BAY PLAZA
1511	DP	NB	PACIFIC COAST	FS	CROWN VALLEY
1512	DP	NB	PACIFIC COAST	FS	VIA MENTONE
1513	DP	SB	PACIFIC COAST	FS	MONARCH BAY
1514	DP	SB	PACIFIC COAST	FS	RITZ-CARLTON
1515	DP	SB	PACIFIC COAST	FS	RITZ-CARLTON
1516	DP	SB	PACIFIC COAST	FS	SELVA
1517	DP	SB	PACIFIC COAST	FS	BINNACLE LANTERN
1518	DP	SB	PACIFIC COAST	FS	DANA POINT HARBOR

Bus Stop Maintenance

RFP 1-3408

All Stop Locations

Exhibit A

Attachment 2

OCTA_ID	CITY	DIR	STREET_OF_TRAVEL	LOC	CROSS_STREET
1519	DP	SB	PACIFIC COAST	NS	BEACH
1520	DP	NB	CROWN VALLEY	OPP	SEVEN SEAS
1521	DP	NB	CROWN VALLEY	OPP	SEA ISLAND
1522	DP	NB	CROWN VALLEY	FS	ENT 32400 THE BLUFFS
1523	DP	SB	CROWN VALLEY	FS	PACIFIC ISLAND
1524	DP	SB	CROWN VALLEY	FS	SEA ISLAND
1525	DP	SB	CROWN VALLEY	NS	SEVEN SEAS
1526	DP	EB	DANA POINT HARBOR	FS	GOLDEN LANTERN
1527	DP	EB	DANA POINT HARBOR	NS	PARK LANTERN
1528	DP	WB	DANA POINT HARBOR	FS	PACIFIC COAST
1529	DP	NB	DEL OBISPO	FS	PACIFIC COAST
1530	DP	NB	DEL OBISPO	OPP	VILLAGE
1531	DP	NB	DEL OBISPO	VFS	QUAIL RUN
1532	DP	NB	DEL OBISPO	FS	LIGHTHOUSE
1533	DP	NB	DEL OBISPO	NS	STONEHILL
1534	DP	NB	DEL OBISPO	FS	GOLDEN SPRING
1535	DP	NB	DEL OBISPO	FS	BLUE SAIL
1536	DP	SB	DEL OBISPO	FS	WESTBORNE
1537	DP	SB	DEL OBISPO	FS	BLUE FIN
1538	DP	SB	DEL OBISPO	OPP	GOLDEN SPRING
1539	DP	SB	DEL OBISPO	FS	STONEHILL
1540	DP	SB	DEL OBISPO	OPP	LIGHTHOUSE
1541	DP	SB	DEL OBISPO	FS	VILLAGE
1542	DP	SB	DEL PRADO	NS	RUBY LANTERN
1543	DP	SB	DEL PRADO	FS	AMBER LANTERN
1544	DP	SB	DEL PRADO	FS	VIOLET LANTERN
1545	DP	SB	DEL PRADO	FS	GOLDEN LANTERN
1546	DP	SB	DEL PRADO	OPP	COPPER LANTERN
1547	DP	NB	DOHENY PARK	FS	DOMINGO
1548	DP	NB	DOHENY PARK	NS	CAMINO CAPISTRANO
1549	DP	SB	DOHENY PARK	FS	DOMINGO
1550	DP	EB	DOMINGO	FS	DOHENY PARK
1551	DP	NB	GOLDEN LANTERN	FS	DANA POINT HARBOR
1552	DP	NB	GOLDEN LANTERN	FS	PACIFIC COAST
1553	DP	NB	GOLDEN LANTERN	NS	LA CRESTA
1554	DP	NB	GOLDEN LANTERN	FS	LA PAZ
1555	DP	NB	GOLDEN LANTERN	FS	SELVA
1556	DP	NB	GOLDEN LANTERN	FS	MERIDIAN
1557	DP	NB	GOLDEN LANTERN	FS	ACAPULCO
1558	DP	NB	GOLDEN LANTERN	FS	OCEAN SPRAY
1559	DP	NB	GOLDEN LANTERN	FS	DANA WOODS
1560	DP	NB	GOLDEN LANTERN	OPP	SEABROOK
1561	DP	SB	GOLDEN LANTERN	FS	CAMINO DEL AVION
1562	DP	SB	GOLDEN LANTERN	FS	SEABROOK
1563	DP	SB	GOLDEN LANTERN	OPP	DANA WOODS
1564	DP	SB	GOLDEN LANTERN	FS	PRISCILLA

Bus Stop Maintenance**All Stop Locations**

RFP 1-3408

Exhibit A

Attachment 2

OCTA_ID	CITY	DIR	STREET_OF_TRAVEL	LOC	CROSS_STREET
1565	DP	SB	GOLDEN LANTERN	FS	ACAPULCO
1566	DP	SB	GOLDEN LANTERN	FS	STONEHILL
1567	DP	SB	GOLDEN LANTERN	NS	SELVA
1568	DP	SB	GOLDEN LANTERN	FS	LA CRESTA
1569	DP	SB	GOLDEN LANTERN	NS	SAN JUAN
1570	DP	SB	GOLDEN LANTERN	FS	DEL PRADO
1571	DP	NB	NIGUEL	FS	STONEHILL
1572	DP	NB	NIGUEL	FS	MONARCH BEACH RESORT
1573	DP	NB	NIGUEL	FS	MONARCH BEACH
1574	DP	SB	NIGUEL	FS	CAMINO DEL AVION
1575	DP	SB	NIGUEL	OPP	MONARCH BEACH
1576	DP	EB	SELVA	FS	PACIFIC COAST
1577	DP	EB	SELVA	FS	GARIBALDI
1578	DP	EB	SELVA	NS	CHULA VISTA
1579	DP	EB	SELVA	NS	GRANADA
1580	DP	EB	SELVA	FS	ROBLES
1581	DP	EB	SELVA	NS	OLINDA
1582	DP	EB	SELVA	NS	GOLDEN LANTERN
1583	DP	WB	SELVA	FS	DISCOVERY
1584	DP	WB	SELVA	OPP	GRANADA
1585	DP	WB	SELVA	FS	CHULA VISTA
1586	DP	WB	SELVA	OPP	GARIBALDI
1587	DP	WB	SELVA	NS	PACIFIC COAST
1588	DP	EB	STONEHILL	FS	NIGUEL
1589	DP	EB	STONEHILL	FS	BLUE LANTERN
1590	DP	EB	STONEHILL	FS	GOLDEN LANTERN
1591	DP	EB	STONEHILL	OPP	OCEAN HILL
1592	DP	EB	STONEHILL	NS	DEL OBISPO
1593	DP	WB	STONEHILL	FS	DEL OBISPO
1594	DP	WB	STONEHILL	FS	OCEAN HILL
1595	DP	WB	STONEHILL	NS	GOLDEN LANTERN
1596	DP	WB	STONEHILL	FS	INTERA
1597	DP	WB	STONEHILL	FS	MONARCH BEACH
1598	DP	EB	VICTORIA	FS	SEPULVEDA
1599	DP	WB	VICTORIA	NS	SANTA ROSA
1600	FULL	NB	ASSOCIATED	FS	YORBA LINDA
1601	FULL	NB	ASSOCIATED	NS	MILTON
1602	FULL	NB	ASSOCIATED	FS	BASTANCHURY
1603	FULL	NB	ASSOCIATED	FS	ENT 2610 CAMDEN PARKSIDE
1604	FULL	NB	ASSOCIATED	OPP	PARK VISTA
1605	FULL	NB	ASSOCIATED	FS	ROLLING HILLS
1606	FULL	NB	ASSOCIATED	FS	GINGERWOOD
1607	FULL	SB	ASSOCIATED	FS	IMPERIAL
1608	FULL	SB	ASSOCIATED	OPP	GINGERWOOD
1609	FULL	SB	ASSOCIATED	FS	PARK VISTA
1610	FULL	SB	ASSOCIATED	FS	CRAIG

Bus Stop Maintenance

RFP 1-3408

All Stop Locations

Exhibit A

Attachment 2

OCTA_ID	CITY	DIR	STREET_OF_TRAVEL	LOC	CROSS_STREET
1611	FULL	SB	ASSOCIATED	OPP	ENT 2610 CAMDEN PARKSIDE
1612	FULL	SB	ASSOCIATED	FS	BASTANCHURY
1613	FULL	SB	ASSOCIATED	FS	NORTH CREEK
1614	FULL	SB	ASSOCIATED	NS	YORBA LINDA
1615	FULL	EB	BASTANCHURY	NS	SILVER PINE
1616	FULL	EB	BASTANCHURY	FS	MORNINGSIDE
1617	FULL	EB	BASTANCHURY	FS	BREA
1618	FULL	EB	BASTANCHURY	FS	MASTERS
1619	FULL	WB	BASTANCHURY	FS	STATE COLLEGE
1620	FULL	WB	BASTANCHURY	FS	ASHWOOD
1621	FULL	WB	BASTANCHURY	FS	VISTA GRANDE
1622	FULL	WB	BASTANCHURY	FS	PUENTE
1623	FULL	WB	BASTANCHURY	FS	FAIRWAY ISLE
1624	FULL	SB	BRADFORD	FS	YORBA LINDA
1625	FULL	SB	BRADFORD	FS	TOPAZ
1626	FULL	NB	BREA	NS	LEMON
1627	FULL	NB	BREA	FS	LONGVIEW
1628	FULL	NB	BREA	FS	PANORAMA
1629	FULL	NB	BREA	FS	BASTANCHURY
1630	FULL	NB	BREA	FS	ROLLING HILLS
1631	FULL	NB	BREA	FS	EVERGREEN
1632	FULL	SB	BREA	NS	ROLLING HILLS
1633	FULL	SB	BREA	OPP	BEECHWOOD
1634	FULL	SB	BREA	FS	BASTANCHURY
1635	FULL	SB	BREA	FS	PANORAMA
1636	FULL	SB	BREA	OPP	LONGVIEW
1637	FULL	SB	BREA	FS	MARION
1638	FULL	NB	BROOKHURST	FS	ROBERTA
1639	FULL	NB	BROOKHURST	FS	ORANGETHORPE
1640	FULL	NB	BROOKHURST	NS	SOUTHGATE
1641	FULL	NB	BROOKHURST	FS	OAK
1642	FULL	NB	BROOKHURST	FS	VALENCIA
1643	FULL	NB	BROOKHURST	VNS	COMMONWEALTH
1644	FULL	SB	BROOKHURST	FS	COMMONWEALTH
1645	FULL	SB	BROOKHURST	FS	VALENCIA
1646	FULL	SB	BROOKHURST	FS	OAK
1647	FULL	SB	BROOKHURST	FS	SOUTHGATE
1648	FULL	SB	BROOKHURST	FS	ORANGETHORPE
1649	FULL	SB	BROOKHURST	FS	PAGE
1650	FULL	EB	MALVERN	FS	GILBERT
1651	FULL	EB	MALVERN	NS	BRIDGEPORT
1652	FULL	EB	MALVERN	OPP	ADLENA
1653	FULL	EB	MALVERN	NS	BASQUE
1654	FULL	EB	MALVERN	NS	EUCLID
1655	FULL	EB	CHAPMAN	FS	WOODS
1656	FULL	EB	CHAPMAN	NS	RICHMAN

Bus Stop Maintenance
All Stop Locations

RFP 1-3408
Exhibit A
Attachment 2

OCTA_ID	CITY	DIR	STREET_OF_TRAVEL	LOC	CROSS_STREET
1657	FULL	EB	CHAPMAN	FS	FORD
1658	FULL	EB	CHAPMAN	NS	HIGHLAND
1659	FULL	EB	CHAPMAN	NS	MALDEN
1660	FULL	EB	CHAPMAN	FS	HARBOR
1661	FULL	EB	CHAPMAN	FS	POMONA
1662	FULL	EB	CHAPMAN	FS	LEMON
1663	FULL	EB	CHAPMAN	VFS	LEMON
1664	FULL	EB	CHAPMAN	FS	BERKELEY
1665	FULL	EB	CHAPMAN	FS	YALE
1666	FULL	EB	CHAPMAN	FS	CORNELL
1667	FULL	EB	CHAPMAN	FS	RAYMOND
1668	FULL	EB	CHAPMAN	OPP	VICTORIA
1669	FULL	EB	CHAPMAN	FS	ANNIN
1670	FULL	EB	CHAPMAN	FS	ACACIA
1671	FULL	EB	CHAPMAN	FS	MOUNTAIN VIEW
1672	FULL	EB	CHAPMAN	OPP	LADERA VISTA
1673	FULL	EB	CHAPMAN	FS	STATE COLLEGE
1674	FULL	EB	CHAPMAN	NS	CLARKE
1675	FULL	EB	CHAPMAN	NS	COMMONWEALTH
1676	FULL	WB	CHAPMAN	FS	PLACENTIA
1677	FULL	WB	CHAPMAN	NS	ENT 2751 LAGURA
1678	FULL	WB	CHAPMAN	FS	STATE COLLEGE
1679	FULL	WB	CHAPMAN	FS	LADERA VISTA
1680	FULL	WB	CHAPMAN	FS	MOUNTAIN VIEW
1681	FULL	WB	CHAPMAN	FS	ACACIA
1682	FULL	WB	CHAPMAN	NS	HART
1683	FULL	WB	CHAPMAN	FS	VICTORIA
1684	FULL	WB	CHAPMAN	FS	RAYMOND
1685	FULL	WB	CHAPMAN	FS	CORNELL
1686	FULL	WB	CHAPMAN	FS	BERKELEY
1687	FULL	WB	CHAPMAN	VNS	LEMON
1688	FULL	WB	CHAPMAN	NS	LEMON
1689	FULL	WB	CHAPMAN	FS	POMONA
1690	FULL	WB	CHAPMAN	FS	HARBOR
1691	FULL	WB	CHAPMAN	NS	MALDEN
1692	FULL	WB	CHAPMAN	FS	HIGHLAND
1693	FULL	WB	CHAPMAN	FS	FORD
1694	FULL	WB	CHAPMAN	NS	RICHMAN
1695	FULL	WB	MALVERN	FS	WOODS
1696	FULL	WB	MALVERN	NS	EUCLID
1697	FULL	WB	MALVERN	FS	BUENA VISTA
1698	FULL	WB	MALVERN	NS	BEVERLY
1699	FULL	WB	MALVERN	FS	CARHART
1700	FULL	WB	MALVERN	NS	ADLENA
1701	FULL	WB	MALVERN	FS	BASTANCHURY
1702	FULL	WB	MALVERN	FS	TARGET

Bus Stop Maintenance

RFP 1-3408

All Stop Locations

Exhibit A

Attachment 2

OCTA_ID	CITY	DIR	STREET_OF_TRAVEL	LOC	CROSS_STREET
1703	FULL	EB	COMMONWEALTH	FS	TURNER
1704	FULL	EB	COMMONWEALTH	FS	MAGNOLIA
1705	FULL	EB	COMMONWEALTH	NS	PRITCHARD
1706	FULL	EB	COMMONWEALTH	NS	JENSEN
1707	FULL	EB	COMMONWEALTH	FS	GILBERT
1708	FULL	EB	COMMONWEALTH	FS	LLOYD
1709	FULL	EB	COMMONWEALTH	FS	BROOKHURST
1710	FULL	EB	COMMONWEALTH	FS	BASQUE
1711	FULL	EB	COMMONWEALTH	FS	CITRUS
1712	FULL	EB	COMMONWEALTH	FS	EUCLID
1713	FULL	EB	COMMONWEALTH	FS	WOODS
1714	FULL	EB	COMMONWEALTH	FS	RICHMAN
1715	FULL	EB	COMMONWEALTH	VNS	HIGHLAND
1716	FULL	EB	COMMONWEALTH	FS	HIGHLAND
1717	FULL	EB	COMMONWEALTH	FS	MALDEN
1718	FULL	EB	COMMONWEALTH	FS	LEMON
1719	FULL	EB	COMMONWEALTH	FS	LAWRENCE
1720	FULL	EB	COMMONWEALTH	FS	BALCOM
1721	FULL	EB	COMMONWEALTH	FS	YALE
1722	FULL	EB	COMMONWEALTH	FS	CORNELL
1723	FULL	EB	COMMONWEALTH	FS	RAYMOND
1724	FULL	EB	COMMONWEALTH	FS	ANNIN
1725	FULL	EB	COMMONWEALTH	NS	ACACIA
1726	FULL	EB	COMMONWEALTH	NS	MOUNTAIN VIEW
1727	FULL	EB	COMMONWEALTH	NS	LILLIE
1728	FULL	EB	COMMONWEALTH	NS	STATE COLLEGE
1729	FULL	NB	COMMONWEALTH	FS	SAN CARLOS
1730	FULL	NB	COMMONWEALTH	FS	CHAPMAN
1731	FULL	NB	COMMONWEALTH	NS	NUTWOOD
1732	FULL	SB	COMMONWEALTH	FS	NUTWOOD
1733	FULL	SB	COMMONWEALTH	NS	COLLEGE
1734	FULL	SB	COMMONWEALTH	NS	CHAPMAN
1735	FULL	SB	COMMONWEALTH	FS	SAN CARLOS
1736	FULL	WB	COMMONWEALTH	NS	MISSION
1737	FULL	WB	COMMONWEALTH	FS	STATE COLLEGE
1738	FULL	WB	COMMONWEALTH	FS	LADERA VISTA
1739	FULL	WB	COMMONWEALTH	OPP	MOUNTAIN VIEW
1740	FULL	WB	COMMONWEALTH	FS	ACACIA
1741	FULL	WB	COMMONWEALTH	FS	ANNIN
1742	FULL	WB	COMMONWEALTH	FS	MONTAGUE
1743	FULL	WB	COMMONWEALTH	NS	RAYMOND
1744	FULL	WB	COMMONWEALTH	NS	YALE
1745	FULL	WB	COMMONWEALTH	FS	PRINCETON
1746	FULL	WB	COMMONWEALTH	FS	BALCOM
1747	FULL	WB	COMMONWEALTH	FS	LAWRENCE
1748	FULL	WB	COMMONWEALTH	NS	LEMON

Bus Stop Maintenance

RFP 1-3408

All Stop Locations

Exhibit A

Attachment 2

OCTA_ID	CITY	DIR	STREET_OF_TRAVEL	LOC	CROSS_STREET
1749	FULL	WB	COMMONWEALTH	NS	MALDEN
1750	FULL	WB	COMMONWEALTH	FS	HIGHLAND
1751	FULL	WB	COMMONWEALTH	NS	SHORT
1752	FULL	WB	COMMONWEALTH	FS	RICHMAN
1753	FULL	WB	COMMONWEALTH	FS	DRAKE
1754	FULL	WB	COMMONWEALTH	FS	WOODS
1755	FULL	WB	COMMONWEALTH	FS	EUCLID
1756	FULL	WB	COMMONWEALTH	OPP	CITRUS
1757	FULL	WB	COMMONWEALTH	NS	BASQUE
1758	FULL	WB	COMMONWEALTH	FS	ALBERTA
1759	FULL	WB	COMMONWEALTH	FS	BROOKHURST
1760	FULL	WB	COMMONWEALTH	OPP	LLOYD
1761	FULL	WB	COMMONWEALTH	FS	GILBERT
1762	FULL	WB	COMMONWEALTH	OPP	JENSEN
1763	FULL	WB	COMMONWEALTH	FS	PRITCHARD
1764	FULL	WB	COMMONWEALTH	NS	MAGNOLIA
1765	FULL	WB	COMMONWEALTH	OPP	EDWARD
1766	FULL	NB	EUCLID	NS	BAKER
1767	FULL	NB	EUCLID	NS	ORANGETHORPE
1768	FULL	NB	EUCLID	NS	SOUTHGATE
1769	FULL	NB	EUCLID	OPP	ASH
1770	FULL	NB	EUCLID	NS	VALENCIA
1771	FULL	NB	EUCLID	FS	COMMONWEALTH
1772	FULL	NB	EUCLID	NS	CHAPMAN
1773	FULL	NB	EUCLID	NS	MALVERN
1774	FULL	NB	EUCLID	NS	FERN
1775	FULL	NB	EUCLID	FS	VALENCIA MESA
1776	FULL	NB	EUCLID	FS	BASTANCHURY
1777	FULL	NB	EUCLID	FS	PASEO DORADO
1778	FULL	NB	EUCLID	OPP	ROSECRANS
1779	FULL	NB	EUCLID	OPP	LAGUNA TERRACE
1780	FULL	NB	EUCLID	NS	LAGUNA
1781	FULL	NB	EUCLID	FS	LAKEVIEW
1782	FULL	NB	EUCLID	FS	LA SENDA
1783	FULL	SB	EUCLID	FS	COUNTRY HILLS
1784	FULL	SB	EUCLID	OPP	LAGUNA
1785	FULL	SB	EUCLID	NS	LAGUNA TERRACE
1786	FULL	SB	EUCLID	FS	ROSECRANS
1787	FULL	SB	EUCLID	NS	PASEO DORADO
1788	FULL	SB	EUCLID	NS	BASTANCHURY
1789	FULL	SB	EUCLID	FS	VALENCIA MESA
1790	FULL	SB	EUCLID	FS	ARROYO
1791	FULL	SB	EUCLID	FS	CHAPMAN
1792	FULL	SB	EUCLID	NS	COMMONWEALTH
1793	FULL	SB	EUCLID	FS	VALENCIA
1794	FULL	SB	EUCLID	NS	ASH

Bus Stop Maintenance

RFP 1-3408

All Stop Locations

Exhibit A

Attachment 2

OCTA_ID	CITY	DIR	STREET_OF_TRAVEL	LOC	CROSS_STREET
1795	FULL	SB	EUCLID	NS	HILL
1796	FULL	SB	EUCLID	FS	ORANGETHORPE
1797	FULL	SB	EUCLID	FS	BAKER
1798	FULL	NB	GILBERT	FS	COMMONWEALTH
1799	FULL	NB	GILBERT	NS	RAYMER
1800	FULL	NB	GILBERT	NS	MOORE
1801	FULL	SB	GILBERT	FS	MALVERN
1802	FULL	SB	GILBERT	FS	MOORE
1803	FULL	SB	GILBERT	FS	RAYMER
1804	FULL	NB	HARBOR	FS	ORANGEFAIR
1805	FULL	NB	HARBOR	FS	ORANGETHORPE
1806	FULL	NB	HARBOR	FS	COSTCO
1807	FULL	NB	HARBOR	NS	VALENCIA
1808	FULL	NB	HARBOR	FS	COMMONWEALTH
1809	FULL	NB	HARBOR	NS	CHAPMAN
1810	FULL	NB	HARBOR	FS	ELLIS
1811	FULL	NB	HARBOR	FS	UNION
1812	FULL	NB	HARBOR	FS	BERKELEY
1813	FULL	NB	HARBOR	FS	BREA
1814	FULL	NB	HARBOR	NS	ENT BREA DAM
1815	FULL	NB	HARBOR	FS	VALENCIA MESA
1816	FULL	NB	HARBOR	FS	BASTANCHURY
1817	FULL	NB	HARBOR	FS	ENT 2700 FULLERTON
1818	FULL	NB	HARBOR	NS	ENT 2800 SUNBRIDGE
1819	FULL	NB	HARBOR	FS	LA ENTRADA
1820	FULL	NB	HARBOR	NS	HERMOSA
1821	FULL	NB	HARBOR	FS	IMPERIAL
1822	FULL	NB	HARBOR	NS	BECKMAN
1823	FULL	SB	HARBOR	OPP	LAS RIENDAS
1824	FULL	SB	HARBOR	FS	LAS PALMAS
1825	FULL	SB	HARBOR	FS	HERMOSA
1826	FULL	SB	HARBOR	FS	LA ENTRADA
1827	FULL	SB	HARBOR	FS	BASTANCHURY
1828	FULL	SB	HARBOR	NS	VALENCIA MESA
1829	FULL	SB	HARBOR	FS	WEST VALLEY VIEW
1830	FULL	SB	HARBOR	NS	BERKELEY
1831	FULL	SB	HARBOR	NS	UNION
1832	FULL	SB	HARBOR	FS	CHAPMAN
1833	FULL	SB	HARBOR	NS	SANTA FE
1834	FULL	SB	HARBOR	FS	ASH
1835	FULL	SB	HARBOR	NS	SOUTHGATE
1836	FULL	SB	HARBOR	FS	ORANGETHORPE
1837	FULL	SB	HARBOR	OPP	ORANGEFAIR
1838	FULL	EB	IMPERIAL	FS	HARBOR
1839	FULL	EB	IMPERIAL	FS	PALM
1840	FULL	EB	IMPERIAL	OPP	GEMINI

Bus Stop Maintenance

RFP 1-3408

All Stop Locations

Exhibit A

Attachment 2

OCTA_ID	CITY	DIR	STREET_OF_TRAVEL	LOC	CROSS_STREET
1841	FULL	WB	IMPERIAL	FS	PALM
1842	FULL	WB	IMPERIAL	NS	HARBOR
1843	FULL	NB	LEMON	NS	VALENCIA
1844	FULL	NB	LEMON	FS	COMMONWEALTH
1845	FULL	NB	LEMON	FS	WILSHIRE
1846	FULL	SB	LEMON	FS	CHAPMAN
1847	FULL	SB	LEMON	FS	WILSHIRE
1848	FULL	SB	LEMON	NS	COMMONWEALTH
1849	FULL	SB	LEMON	FS	VALENCIA
1850	FULL	SB	LEMON	OPP	FREEDOM
1851	FULL	SB	LEMON	FS	ORANGETHORPE
1852	FULL	SB	LEMON	FS	ORANGEFAIR
1853	FULL	NB	MAGNOLIA	NS	PORTER
1854	FULL	NB	MAGNOLIA	NS	OLIVE
1855	FULL	NB	MAGNOLIA	FS	OAK
1856	FULL	NB	MAGNOLIA	NS	VALENCIA
1857	FULL	SB	MAGNOLIA	FS	COMMONWEALTH
1858	FULL	SB	MAGNOLIA	NS	ORANGETHORPE
1859	FULL	EB	NUTWOOD	FS	STATE COLLEGE
1860	FULL	EB	NUTWOOD	FS	COMMONWEALTH
1861	FULL	EB	NUTWOOD	FS	LANGSDORF
1862	FULL	WB	NUTWOOD	FS	PLACENTIA
1863	FULL	WB	NUTWOOD	OPP	LANGSDORF
1864	FULL	WB	NUTWOOD	OPP	COMMONWEALTH
1865	FULL	WB	NUTWOOD	OPP	TITAN
1866	FULL	EB	ORANGETHORPE	OPP	AUTO CENTER
1867	FULL	EB	ORANGETHORPE	FS	EXIT PARK-N-RIDE
1868	FULL	EB	ORANGETHORPE	FS	MAGNOLIA
1869	FULL	EB	ORANGETHORPE	FS	VINE
1870	FULL	EB	ORANGETHORPE	NS	PECKHAM
1871	FULL	EB	ORANGETHORPE	FS	GILBERT
1872	FULL	EB	ORANGETHORPE	OPP	COURTNEY
1873	FULL	EB	ORANGETHORPE	FS	BROOKHURST
1874	FULL	EB	ORANGETHORPE	NS	PACIFIC
1875	FULL	EB	ORANGETHORPE	FS	EADINGTON
1876	FULL	EB	ORANGETHORPE	FS	BASQUE
1877	FULL	EB	ORANGETHORPE	FS	ORCHARD
1878	FULL	EB	ORANGETHORPE	FS	EUCLID
1879	FULL	EB	ORANGETHORPE	FS	WOODS
1880	FULL	EB	ORANGETHORPE	FS	RICHMAN
1881	FULL	EB	ORANGETHORPE	FS	HIGHLAND
1882	FULL	EB	ORANGETHORPE	FS	HARBOR
1883	FULL	EB	ORANGETHORPE	FS	RAYMOND
1884	FULL	EB	ORANGETHORPE	NS	MANHATTAN
1885	FULL	EB	ORANGETHORPE	NS	ACACIA
1886	FULL	EB	ORANGETHORPE	NS	ENT 2150 VISTA PAINT

Bus Stop Maintenance

RFP 1-3408

All Stop Locations

Exhibit A

Attachment 2

OCTA_ID	CITY	DIR	STREET_OF_TRAVEL	LOC	CROSS_STREET
1887	FULL	WB	ORANGETHORPE	FS	PLACENTIA
1888	FULL	WB	ORANGETHORPE	FS	STATE COLLEGE
1889	FULL	WB	ORANGETHORPE	OPP	ENT 2100 COLT
1890	FULL	WB	ORANGETHORPE	FS	ACACIA
1891	FULL	WB	ORANGETHORPE	OPP	MANHATTAN
1892	FULL	WB	ORANGETHORPE	FS	LEMON
1893	FULL	WB	ORANGETHORPE	NS	HARBOR
1894	FULL	WB	ORANGETHORPE	FS	HIGHLAND
1895	FULL	WB	ORANGETHORPE	FS	RICHMAN
1896	FULL	WB	ORANGETHORPE	FS	WOODS
1897	FULL	WB	ORANGETHORPE	FS	EUCLID
1898	FULL	WB	ORANGETHORPE	FS	ORCHARD
1899	FULL	WB	ORANGETHORPE	FS	BASQUE
1900	FULL	WB	ORANGETHORPE	OPP	EADINGTON
1901	FULL	WB	ORANGETHORPE	FS	PACIFIC
1902	FULL	WB	ORANGETHORPE	FS	BROOKHURST
1903	FULL	WB	ORANGETHORPE	FS	COURTNEY
1904	FULL	WB	ORANGETHORPE	NS	GILBERT
1905	FULL	WB	ORANGETHORPE	OPP	PECKHAM
1906	FULL	WB	ORANGETHORPE	OPP	VINE
1907	FULL	NB	PLACENTIA	NS	MADISON
1908	FULL	NB	PLACENTIA	FS	QUARTZ
1909	FULL	NB	PLACENTIA	FS	GARNET
1910	FULL	SB	PLACENTIA	FS	YORBA LINDA
1911	FULL	SB	PLACENTIA	FS	GARNET
1912	FULL	SB	PLACENTIA	OPP	QUARTZ
1913	FULL	SB	PLACENTIA	FS	MADISON
1914	FULL	SB	PLACENTIA	FS	RUBY
1915	FULL	SB	PLACENTIA	FS	NUTWOOD
1916	FULL	SB	PLACENTIA	OPP	HARMONY
1917	FULL	SB	POMONA	FS	CHAPMAN
1918	FULL	NB	RAYMOND	OPP	ORANGEFAIR
1919	FULL	NB	RAYMOND	FS	ORANGETHORPE
1920	FULL	NB	RAYMOND	OPP	ELM
1921	FULL	NB	RAYMOND	NS	VALENCIA
1922	FULL	NB	RAYMOND	FS	COMMONWEALTH
1923	FULL	SB	RAYMOND	NS	WHITING
1924	FULL	SB	RAYMOND	FS	SUDENE
1925	FULL	SB	RAYMOND	FS	TRUSLOW
1926	FULL	SB	RAYMOND	FS	ELM
1927	FULL	NB	STATE COLLEGE	FS	CYPRESS
1928	FULL	NB	STATE COLLEGE	NS	ENT 660 ROPAK
1929	FULL	NB	STATE COLLEGE	NS	FENDER
1930	FULL	NB	STATE COLLEGE	FS	COMMONWEALTH
1931	FULL	NB	STATE COLLEGE	FS	CHAPMAN
1932	FULL	NB	STATE COLLEGE	FS	NUTWOOD

Bus Stop Maintenance

All Stop Locations

RFP 1-3408

Exhibit A

Attachment 2

OCTA_ID	CITY	DIR	STREET_OF_TRAVEL	LOC	CROSS_STREET
1933	FULL	NB	STATE COLLEGE	FS	CAMPUS
1934	FULL	NB	STATE COLLEGE	FS	CORPORATION
1935	FULL	NB	STATE COLLEGE	VFS	YORBA LINDA
1936	FULL	NB	STATE COLLEGE	FS	VISTA DEL SOL
1937	FULL	NB	STATE COLLEGE	NS	MOUNTAIN RIDGE
1938	FULL	SB	STATE COLLEGE	FS	DELICATA
1939	FULL	SB	STATE COLLEGE	FS	BASTANCHURY
1940	FULL	SB	STATE COLLEGE	FS	PALMETTO TERRACE
1941	FULL	SB	STATE COLLEGE	FS	MENDOCINO
1942	FULL	SB	STATE COLLEGE	FS	YORBA LINDA
1943	FULL	SB	STATE COLLEGE	FS	RANCH
1944	FULL	SB	STATE COLLEGE	FS	DOROTHY
1945	FULL	SB	STATE COLLEGE	FS	NUTWOOD
1946	FULL	SB	STATE COLLEGE	FS	CHAPMAN
1947	FULL	SB	STATE COLLEGE	FS	COMMONWEALTH
1948	FULL	SB	STATE COLLEGE	NS	VALENCIA
1949	FULL	SB	STATE COLLEGE	NS	KIMBERLY
1950	FULL	SB	STATE COLLEGE	FS	ORANGETHORPE
1951	FULL	EB	YORBA LINDA	FS	STATE COLLEGE
1952	FULL	EB	YORBA LINDA	FS	PLACENTIA
1953	FULL	EB	YORBA LINDA	FS	SAPPHIRE
1954	FULL	EB	YORBA LINDA	NS	BRADFORD
1955	FULL	WB	YORBA LINDA	FS	BRADFORD
1956	FULL	WB	YORBA LINDA	OPP	SAPPHIRE
1957	FULL	WB	YORBA LINDA	FS	ALMIRA
1958	FULL	SB	FULLERTON AMTACK STATION	FS	SANTA FE
1959	FULL	WB	WALNUT	@	BOARDING DOCK
1960	FULL	SB	FTC	NS	SANTA FE
1961	FULL	WB	FTC	FS	POMONA
1962	FULL	EB	FTC	NS	POMONA
1963	FULL	NB	FTC	FS	SANTA FE
1964	FULL	WB	FULLERTON PNR	@	DOCK 0
1965	FULL	WB	FULLERTON PNR	@	DOCK 1
1966	FULL	WB	FULLERTON PNR	@	DOCK 2
1967	FULL	WB	FULLERTON PNR	@	DOCK 3
1968	FULL	WB	FULLERTON PNR	@	DOCK 4
1969	FULL	WB	FULLERTON PNR	@	DOCK 5
1970	FULL	WB	FULLERTON PNR	@	DOCK 6
1971	FULL	WB	FULLERTON PNR	@	DOCK 7
1972	FULL	WB	FULLERTON PNR	@	DOCK 8
1973	FULL	WB	FULLERTON PNR	@	DOCK 9
1974	FULL	WB	FULLERTON PNR	@	DOCK 10
1975	FULL	WB	FULLERTON PNR	@	DOCK 11
1976	FULL	WB	FULLERTON PNR	@	DOCK 12
1977	FULL	WB	FULLERTON PNR	@	DOCK 13
1978	FULL	WB	FULLERTON PNR	@	DOCK 14

Bus Stop Maintenance

RFP 1-3408

All Stop Locations

Exhibit A

Attachment 2

OCTA_ID	CITY	DIR	STREET_OF_TRAVEL	LOC	CROSS_STREET
1979	FULL	NB	INTERIOR	@	BLDG 676
1980	FULL	WB	INTERIOR	@	BLDG 617
1981	FV	NB	BROOKHURST	FS	GARFIELD
1982	FV	NB	BROOKHURST	OPP	NIAGARA RIVER
1983	FV	NB	BROOKHURST	NS	ENT 18650 CHATEAU
1984	FV	NB	BROOKHURST	FS	ELLIS
1985	FV	NB	BROOKHURST	FS	QUAIL
1986	FV	NB	BROOKHURST	NS	STONE FIELD
1987	FV	NB	BROOKHURST	FS	TALBERT
1988	FV	NB	BROOKHURST	FS	SLATER
1989	FV	NB	BROOKHURST	NS	LA ALAMEDA
1990	FV	NB	BROOKHURST	FS	WARNER
1991	FV	NB	BROOKHURST	OPP	PETUNIA
1992	FV	NB	BROOKHURST	OPP	HEIL
1993	FV	NB	BROOKHURST	OPP	THISTLE
1994	FV	NB	BROOKHURST	FS	EDINGER
1995	FV	SB	BROOKHURST	FS	EDINGER
1996	FV	SB	BROOKHURST	FS	THISTLE
1997	FV	SB	BROOKHURST	FS	HEIL
1998	FV	SB	BROOKHURST	FS	PETUNIA
1999	FV	SB	BROOKHURST	FS	WARNER
2000	FV	SB	BROOKHURST	FS	LA ALAMEDA
2001	FV	SB	BROOKHURST	FS	SLATER
2002	FV	SB	BROOKHURST	FS	TALBERT
2003	FV	SB	BROOKHURST	FS	PHILLIPS
2004	FV	SB	BROOKHURST	FS	ELLIS
2005	FV	SB	BROOKHURST	NS	NIAGARA RIVER
2006	FV	EB	EDINGER	FS	MAGNOLIA
2007	FV	EB	EDINGER	FS	SWEETLEAF
2008	FV	EB	EDINGER	FS	BUSHARD
2009	FV	EB	EDINGER	FS	BASIL
2010	FV	EB	EDINGER	OPP	LAS FLORES
2011	FV	EB	EDINGER	FS	WARD
2012	FV	EB	EDINGER	OPP	LOS GATOS
2013	FV	EB	EDINGER	FS	EUCLID
2014	FV	EB	EDINGER	NS	MOUNT HICKS
2015	FV	EB	EDINGER	FS	NEWHOPE
2016	FV	EB	EDINGER	OPP	RICHARDSON
2017	FV	EB	EDINGER	FS	IRIS
2018	FV	WB	EDINGER	FS	HARBOR
2019	FV	WB	EDINGER	VFS	HARBOR
2020	FV	WB	EDINGER	FS	MOUNT OLANCHA
2021	FV	WB	EDINGER	FS	RICHARDSON
2022	FV	WB	EDINGER	FS	EUCLID
2023	FV	WB	EDINGER	FS	LOS GATOS
2024	FV	WB	EDINGER	FS	WARD

Bus Stop Maintenance

All Stop Locations

RFP 1-3408

Exhibit A

Attachment 2

OCTA_ID	CITY	DIR	STREET_OF_TRAVEL	LOC	CROSS_STREET
2025	FV	WB	EDINGER	FS	LAS FLORES
2026	FV	WB	EDINGER	FS	BROOKHURST
2027	FV	WB	EDINGER	FS	HIRAM
2028	FV	EB	ELLIS	FS	BROOKHURST
2029	FV	EB	ELLIS	FS	LAS FLORES
2030	FV	EB	ELLIS	FS	WARD
2031	FV	WB	ELLIS	NS	PACIFIC
2032	FV	WB	ELLIS	NS	BANDILIER
2033	FV	WB	ELLIS	FS	MOUNT LANGLEY
2034	FV	WB	ELLIS	FS	WARD
2035	FV	WB	ELLIS	OPP	LAS FLORES
2036	FV	NB	EUCLID	OPP	405 FRWY OFF-RAMP
2037	FV	NB	EUCLID	FS	CONDOR
2038	FV	NB	EUCLID	FS	TALBERT
2039	FV	NB	EUCLID	FS	SOUTHPARK
2040	FV	NB	EUCLID	FS	SLATER
2041	FV	NB	EUCLID	FS	ENT 17300 VALLEY PARK
2042	FV	NB	EUCLID	VNS	WARNER
2043	FV	NB	EUCLID	FS	WARNER
2044	FV	NB	EUCLID	FS	CAMELLIA
2045	FV	NB	EUCLID	FS	LAVENDER
2046	FV	NB	EUCLID	FS	BLUE ALLIUM
2047	FV	NB	EUCLID	FS	BELFLOWER
2048	FV	NB	EUCLID	FS	EDINGER
2049	FV	NB	EUCLID	VFS	EDINGER
2050	FV	SB	EUCLID	NS	EDINGER
2051	FV	SB	EUCLID	OPP	BELFLOWER
2052	FV	SB	EUCLID	OPP	BLUE ALLIUM
2053	FV	SB	EUCLID	OPP	LAVENDER
2054	FV	SB	EUCLID	OPP	CAMELLIA
2055	FV	SB	EUCLID	FS	WARNER
2056	FV	SB	EUCLID	OPP	ENT 17300 VALLEY PARK
2057	FV	SB	EUCLID	FS	SLATER
2058	FV	SB	EUCLID	OPP	SOUTHPARK
2059	FV	SB	EUCLID	NS	TALBERT
2060	FV	SB	EUCLID	NS	KALAMA RIVER
2061	FV	SB	EUCLID	FS	CONDOR
2062	FV	WB	GARFIELD	FS	BROOKHURST
2063	FV	WB	GARFIELD	FS	PERSIMMON
2064	FV	WB	GARFIELD	FS	BUSHARD
2065	FV	WB	GARFIELD	FS	PAULINE
2066	FV	WB	GARFIELD	FS	ACACIA
2067	FV	WB	GARFIELD	FS	MAGNOLIA
2068	FV	WB	GARFIELD	NS	SANTA CATHERINE
2069	FV	WB	GARFIELD	NS	DAKOTA
2070	FV	NB	HARBOR	OPP	HEIL

Bus Stop Maintenance

All Stop Locations

RFP 1-3408

Exhibit A

Attachment 2

OCTA_ID	CITY	DIR	STREET_OF_TRAVEL	LOC	CROSS_STREET
2071	FV	NB	HARBOR	FS	EDINGER
2072	FV	NB	HARBOR	FS	LILAC
2073	FV	SB	HARBOR	FS	LILAC
2074	FV	SB	HARBOR	VFS	LILAC
2075	FV	SB	HARBOR	NS	EDINGER
2076	FV	SB	HARBOR	FS	HEIL
2077	FV	NB	MAGNOLIA	FS	GARFIELD
2078	FV	NB	MAGNOLIA	FS	JAY
2079	FV	NB	MAGNOLIA	NS	ELLIS
2080	FV	NB	MAGNOLIA	OPP	NILE RIVER
2081	FV	NB	MAGNOLIA	FS	HELM
2082	FV	NB	MAGNOLIA	FS	TALBERT
2083	FV	NB	MAGNOLIA	FS	WINDSOR
2084	FV	NB	MAGNOLIA	FS	SLATER
2085	FV	NB	MAGNOLIA	FS	LA STELLA
2086	FV	NB	MAGNOLIA	NS	LA PALOMA
2087	FV	NB	MAGNOLIA	FS	WARNER
2088	FV	NB	MAGNOLIA	FS	HEIL
2089	FV	NB	MAGNOLIA	NS	FOXGLOVE
2090	FV	NB	MAGNOLIA	FS	MINT
2091	FV	SB	MAGNOLIA	FS	WARNER
2092	FV	SB	MAGNOLIA	OPP	LA PALOMA
2093	FV	SB	MAGNOLIA	FS	LA STELLA
2094	FV	SB	MAGNOLIA	FS	SLATER
2095	FV	SB	MAGNOLIA	FS	EL PRESIDENTE
2096	FV	SB	MAGNOLIA	FS	LA ROCA
2097	FV	SB	MAGNOLIA	FS	TALBERT
2098	FV	SB	MAGNOLIA	FS	RHINE RIVER
2099	FV	SB	MAGNOLIA	NS	NILE RIVER
2100	FV	SB	MAGNOLIA	FS	ELLIS
2101	FV	SB	MAGNOLIA	FS	NIGHTINGALE
2102	FV	NB	NEWHOPE	FS	SLATER
2103	FV	NB	NEWHOPE	FS	COLEY RIVER
2104	FV	NB	NEWHOPE	OPP	ENT 17195 WARNER
2105	FV	NB	NEWHOPE	FS	WARNER
2106	FV	NB	NEWHOPE	OPP	CORIENDER
2107	FV	NB	NEWHOPE	FS	HEIL
2108	FV	NB	NEWHOPE	NS	HOLLY
2109	FV	NB	NEWHOPE	NS	ORCHID
2110	FV	NB	NEWHOPE	NS	EDINGER
2111	FV	SB	NEWHOPE	FS	EDINGER
2112	FV	SB	NEWHOPE	NS	PRIMROSE
2113	FV	SB	NEWHOPE	NS	OPAL
2114	FV	SB	NEWHOPE	FS	HEIL
2115	FV	SB	NEWHOPE	FS	CORIENDER
2116	FV	SB	NEWHOPE	NS	WARNER

Bus Stop Maintenance

RFP 1-3408

All Stop Locations

Exhibit A

Attachment 2

OCTA_ID	CITY	DIR	STREET_OF_TRAVEL	LOC	CROSS_STREET
2117	FV	SB	NEWHOPE	VFS	WARNER
2118	FV	SB	NEWHOPE	OPP	COLEY RIVER
2119	FV	SB	NEWHOPE	FS	SOUTHPARK
2120	FV	EB	SLATER	FS	EUCLID
2121	FV	EB	SLATER	NS	NEWHOPE
2122	FV	WB	SLATER	FS	NEWHOPE
2123	FV	WB	SLATER	FS	MOUNT HERRMANN
2124	FV	EB	TALBERT	FS	NEWLAND
2125	FV	EB	TALBERT	FS	SANTA CECILIA
2126	FV	EB	TALBERT	FS	MAGNOLIA
2127	FV	EB	TALBERT	FS	2ND
2128	FV	EB	TALBERT	OPP	OAK
2129	FV	EB	TALBERT	FS	BUSHARD
2130	FV	EB	TALBERT	FS	LEMON
2131	FV	EB	TALBERT	NS	BROOKHURST
2132	FV	EB	TALBERT	NS	WARD
2133	FV	EB	TALBERT	NS	MOUNT SHAY
2134	FV	EB	TALBERT	FS	EUCLID
2135	FV	EB	TALBERT	FS	MOUNT WASHINGTON
2136	FV	WB	TALBERT	OPP	MOUNT WASHINGTON
2137	FV	WB	TALBERT	FS	EUCLID
2138	FV	WB	TALBERT	FS	LOS TIEMPOS
2139	FV	WB	TALBERT	FS	WARD
2140	FV	WB	TALBERT	FS	BROOKHURST
2141	FV	WB	TALBERT	NS	CASHEW
2142	FV	WB	TALBERT	NS	CYPRESS
2143	FV	WB	TALBERT	FS	BUSHARD
2144	FV	WB	TALBERT	FS	OAK
2145	FV	WB	TALBERT	FS	MAGNOLIA
2146	FV	WB	TALBERT	FS	SANTA MARIANA
2147	FV	WB	TALBERT	NS	NEWLAND
2148	FV	NB	WARD	FS	ELLIS
2149	FV	NB	WARD	FS	LAWSON RIVER
2150	FV	NB	WARD	OPP	APACHE RIVER
2151	FV	SB	WARD	FS	TALBERT
2152	FV	SB	WARD	FS	APACHE RIVER
2153	FV	EB	WARNER	FS	NEWLAND
2154	FV	EB	WARNER	FS	ROSS
2155	FV	EB	WARNER	NS	MAGNOLIA
2156	FV	EB	WARNER	FS	BUSHARD
2157	FV	EB	WARNER	FS	GREENLEAF
2158	FV	EB	WARNER	FS	NECTARINE
2159	FV	EB	WARNER	FS	BROOKHURST
2160	FV	EB	WARNER	NS	SAN BRUNO
2161	FV	EB	WARNER	FS	WARD
2162	FV	EB	WARNER	FS	LOS JARDINES WEST

Bus Stop Maintenance

RFP 1-3408

All Stop Locations

Exhibit A

Attachment 2

OCTA_ID	CITY	DIR	STREET_OF_TRAVEL	LOC	CROSS_STREET
2163	FV	EB	WARNER	FS	EUCLID
2164	FV	EB	WARNER	FS	MOUNT HOPE
2165	FV	EB	WARNER	FS	NEWHOPE
2166	FV	EB	WARNER	OPP	WINTERBURG
2167	FV	WB	WARNER	FS	WINTERBURG
2168	FV	WB	WARNER	FS	NEWHOPE
2169	FV	WB	WARNER	NS	MOUNT MARCUS
2170	FV	WB	WARNER	FS	EUCLID
2171	FV	WB	WARNER	OPP	LOS JARDINES WEST
2172	FV	WB	WARNER	OPP	SAN BRUNO
2173	FV	WB	WARNER	FS	BROOKHURST
2174	FV	WB	WARNER	OPP	GREENLEAF
2175	FV	WB	WARNER	VNS	BUSHARD
2176	FV	NB	BUSHARD	FS	EDINGER
2177	GG	SB	BEACH	NS	GARDEN GROVE
2178	GG	WB	BELGRAVE	FS	VALLEY VIEW
2179	GG	NB	BAILEY	OPP	LAURELTON
2180	GG	NB	BAILEY	NS	CHAPMAN
2181	GG	EB	BOLSA	NS	STARBOARD
2182	GG	WB	BOLSA	NS	WARD
2183	GG	NB	BROOKHURST	FS	HAZARD
2184	GG	NB	BROOKHURST	FS	JENNRICH
2185	GG	NB	BROOKHURST	FS	WESTMINSTER
2186	GG	NB	BROOKHURST	NS	TRAYLOR
2187	GG	NB	BROOKHURST	FS	TRASK
2188	GG	NB	BROOKHURST	FS	CENTRAL
2189	GG	NB	BROOKHURST	VFS	GARDEN GROVE
2190	GG	NB	BROOKHURST	NS	STANFORD
2191	GG	NB	BROOKHURST	FS	LAMPSON
2192	GG	NB	BROOKHURST	OPP	BIXBY
2193	GG	NB	BROOKHURST	OPP	PAVILION PLAZA
2194	GG	NB	BROOKHURST	FS	CHAPMAN
2195	GG	NB	BROOKHURST	FS	MCMICHAEL
2196	GG	NB	BROOKHURST	NS	ORANGEWOOD
2197	GG	NB	BROOKHURST	FS	BROOKSIDE
2198	GG	SB	BROOKHURST	FS	KATELLA
2199	GG	SB	BROOKHURST	FS	DEWEY
2200	GG	SB	BROOKHURST	FS	ORANGEWOOD
2201	GG	SB	BROOKHURST	FS	SKYLARK
2202	GG	SB	BROOKHURST	FS	CHAPMAN
2203	GG	SB	BROOKHURST	FS	BIXBY
2204	GG	SB	BROOKHURST	NS	LAMPSON
2205	GG	SB	BROOKHURST	FS	STANFORD
2206	GG	SB	BROOKHURST	FS	GARDEN GROVE
2207	GG	SB	BROOKHURST	NS	CENTRAL
2208	GG	SB	BROOKHURST	FS	TRASK

Bus Stop Maintenance

RFP 1-3408

All Stop Locations

Exhibit A

Attachment 2

OCTA_ID	CITY	DIR	STREET_OF_TRAVEL	LOC	CROSS_STREET
2209	GG	SB	BROOKHURST	FS	WOODBURY
2210	GG	SB	BROOKHURST	FS	WESTMINSTER
2211	GG	SB	BROOKHURST	FS	13TH
2212	GG	EB	CHAPMAN	FS	VALLEY VIEW
2213	GG	EB	CHAPMAN	FS	JASPER
2214	GG	EB	CHAPMAN	FS	SPRINGDALE
2215	GG	EB	CHAPMAN	FS	LAMPLIGHTER
2216	GG	EB	CHAPMAN	FS	KNOTT
2217	GG	EB	CHAPMAN	FS	INDUSTRY
2218	GG	EB	CHAPMAN	NS	MONARCH
2219	GG	EB	CHAPMAN	NS	WESTERN
2220	GG	EB	CHAPMAN	FS	SANTA ROSALIA
2221	GG	EB	CHAPMAN	OPP	MACNAB
2222	GG	EB	CHAPMAN	FS	MAGNOLIA
2223	GG	EB	CHAPMAN	NS	LORALEEN
2224	GG	EB	CHAPMAN	FS	GILBERT
2225	GG	EB	CHAPMAN	OPP	ENT GARDEN GROVE
2226	GG	EB	CHAPMAN	NS	BROOKHURST
2227	GG	EB	CHAPMAN	NS	BROOKHAVEN
2228	GG	EB	CHAPMAN	FS	PARK
2229	GG	EB	CHAPMAN	FS	MORRIE
2230	GG	EB	CHAPMAN	FS	NUTWOOD
2231	GG	EB	CHAPMAN	NS	NELSON
2232	GG	EB	CHAPMAN	FS	EUCLID
2233	GG	EB	CHAPMAN	OPP	LOARA
2234	GG	EB	CHAPMAN	FS	9TH
2235	GG	EB	CHAPMAN	@	JANETTE
2236	GG	EB	CHAPMAN	OPP	JACALENE
2237	GG	EB	CHAPMAN	FS	WEST
2238	GG	EB	CHAPMAN	FS	BUARO
2239	GG	EB	CHAPMAN	FS	HARBOR
2240	GG	EB	CHAPMAN	OPP	SOMERSET
2241	GG	EB	CHAPMAN	FS	HASTER
2242	GG	EB	CHAPMAN	OPP	JETTY
2243	GG	WB	CHAPMAN	FS	HASTER
2244	GG	WB	CHAPMAN	FS	HARBOR
2245	GG	WB	CHAPMAN	OPP	BUARO
2246	GG	WB	CHAPMAN	FS	WEST
2247	GG	WB	CHAPMAN	FS	JACALENE
2248	GG	WB	CHAPMAN	@	JANETTE
2249	GG	WB	CHAPMAN	FS	9TH
2250	GG	WB	CHAPMAN	FS	LOARA
2251	GG	WB	CHAPMAN	FS	EUCLID
2252	GG	WB	CHAPMAN	NS	MEDINA
2253	GG	WB	CHAPMAN	FS	NUTWOOD
2254	GG	WB	CHAPMAN	FS	SEACREST

Bus Stop Maintenance

RFP 1-3408

All Stop Locations

Exhibit A

Attachment 2

OCTA_ID	CITY	DIR	STREET_OF_TRAVEL	LOC	CROSS_STREET
2255	GG	WB	CHAPMAN	NS	BROOKHAVEN
2256	GG	WB	CHAPMAN	FS	BROOKHURST
2257	GG	WB	CHAPMAN	NS	ENT GARDEN GROVE
2258	GG	WB	CHAPMAN	NS	GILBERT
2259	GG	WB	CHAPMAN	FS	LORALEEN
2260	GG	WB	CHAPMAN	FS	MAGNOLIA
2261	GG	WB	CHAPMAN	FS	MACNAB
2262	GG	WB	CHAPMAN	FS	DALE
2263	GG	WB	CHAPMAN	FS	WESTERN
2264	GG	WB	CHAPMAN	FS	MONARCH
2265	GG	WB	CHAPMAN	OPP	INDUSTRY
2266	GG	WB	CHAPMAN	FS	KNOTT
2267	GG	WB	CHAPMAN	FS	LAMPLIGHTER
2268	GG	WB	CHAPMAN	FS	SPRINGDALE
2269	GG	WB	CHAPMAN	FS	ONYX
2270	GG	WB	CHAPMAN	FS	EMERALD
2271	GG	NB	EUCLID	FS	WESTMINSTER
2272	GG	NB	EUCLID	NS	WOODBURY
2273	GG	NB	EUCLID	FS	TRASK
2274	GG	NB	EUCLID	OPP	CENTURY
2275	GG	NB	EUCLID	NS	SHERMAN
2276	GG	NB	EUCLID	FS	GARDEN GROVE
2277	GG	NB	EUCLID	FS	ACACIA
2278	GG	NB	EUCLID	FS	STANFORD
2279	GG	NB	EUCLID	NS	COLLEGE
2280	GG	NB	EUCLID	FS	LAMPSON
2281	GG	NB	EUCLID	NS	JERRY
2282	GG	NB	EUCLID	OPP	MARIAN
2283	GG	NB	EUCLID	FS	CHAPMAN
2284	GG	NB	EUCLID	FS	WAKEFIELD
2285	GG	SB	EUCLID	FS	KATELLA
2286	GG	SB	EUCLID	FS	PALMA VISTA
2287	GG	SB	EUCLID	NS	ORANGEWOOD
2288	GG	SB	EUCLID	FS	PATRICIA
2289	GG	SB	EUCLID	FS	CHAPMAN
2290	GG	SB	EUCLID	FS	MARIAN
2291	GG	SB	EUCLID	FS	LAMPSON
2292	GG	SB	EUCLID	FS	MAIN
2293	GG	SB	EUCLID	OPP	STANFORD
2294	GG	SB	EUCLID	FS	ACACIA
2295	GG	SB	EUCLID	FS	GARDEN GROVE
2296	GG	SB	EUCLID	OPP	SHERMAN
2297	GG	SB	EUCLID	FS	CENTURY
2298	GG	SB	EUCLID	FS	TRASK
2299	GG	SB	EUCLID	NS	BLAKE
2300	GG	SB	EUCLID	FS	WESTMINSTER

Bus Stop Maintenance

RFP 1-3408

All Stop Locations

Exhibit A

Attachment 2

OCTA_ID	CITY	DIR	STREET_OF_TRAVEL	LOC	CROSS_STREET
2301	GG	SB	EUCLID	NS	BUSINESS CENTER
2302	GG	SB	EUCLID	NS	HAZARD
2303	GG	SB	FAIRVIEW	FS	GARDEN GROVE
2304	GG	SB	FAIRVIEW	NS	DOWNIE
2305	GG	SB	FAIRVIEW	FS	TRASK
2306	GG	EB	GARDEN GROVE	FS	BEACH
2307	GG	EB	GARDEN GROVE	FS	COAST
2308	GG	EB	GARDEN GROVE	NS	MONROE
2309	GG	EB	GARDEN GROVE	FS	WILSON
2310	GG	EB	GARDEN GROVE	OPP	JOSEPHINE
2311	GG	EB	GARDEN GROVE	NS	YOCKEY
2312	GG	EB	GARDEN GROVE	NS	MAGNOLIA
2313	GG	EB	GARDEN GROVE	FS	CANNERY
2314	GG	EB	GARDEN GROVE	FS	CASA LINDA
2315	GG	EB	GARDEN GROVE	FS	GILBERT
2316	GG	EB	GARDEN GROVE	FS	GALWAY
2317	GG	EB	GARDEN GROVE	FS	BROOKHURST
2318	GG	EB	GARDEN GROVE	FS	BROOKHURST
2319	GG	EB	GARDEN GROVE	OPP	NUTWOOD
2320	GG	EB	GARDEN GROVE	NS	CENTURY
2321	GG	EB	GARDEN GROVE	FS	MAIN
2322	GG	EB	GARDEN GROVE	FS	EUCLID
2323	GG	EB	GARDEN GROVE	OPP	CIVIC CENTER
2324	GG	EB	GARDEN GROVE	NS	NINA
2325	GG	EB	GARDEN GROVE	FS	NEWHOPE
2326	GG	EB	GARDEN GROVE	FS	LEMONWOOD
2327	GG	EB	GARDEN GROVE	NS	WEST
2328	GG	EB	GARDEN GROVE	FS	HARBOR
2329	GG	EB	GARDEN GROVE	FS	RAINBOW
2330	GG	EB	GARDEN GROVE	NS	BLACKBIRD
2331	GG	EB	GARDEN GROVE	FS	PARTRIDGE
2332	GG	EB	GARDEN GROVE	OPP	HASTER
2333	GG	EB	GARDEN GROVE	FS	FAIRVIEW
2334	GG	EB	GARDEN GROVE	FS	LAIRD
2335	GG	EB	GARDEN GROVE	FS	LEWIS
2336	GG	EB	GARDEN GROVE	NS	SIEMON
2337	GG	WB	GARDEN GROVE	FS	LEWIS
2338	GG	WB	GARDEN GROVE	OPP	FAIRVIEW
2339	GG	WB	GARDEN GROVE	FS	HASTER
2340	GG	WB	GARDEN GROVE	OPP	PARTRIDGE
2341	GG	WB	GARDEN GROVE	NS	PALM
2342	GG	WB	GARDEN GROVE	NS	HARBOR
2343	GG	WB	GARDEN GROVE	FS	WEST
2344	GG	WB	GARDEN GROVE	FS	LEMONWOOD
2345	GG	WB	GARDEN GROVE	FS	NEWHOPE
2346	GG	WB	GARDEN GROVE	FS	9TH

Bus Stop Maintenance

RFP 1-3408

All Stop Locations

Exhibit A

Attachment 2

OCTA_ID	CITY	DIR	STREET_OF_TRAVEL	LOC	CROSS_STREET
2347	GG	WB	GARDEN GROVE	FS	CIVIC CENTER
2348	GG	WB	GARDEN GROVE	FS	EUCLID
2349	GG	WB	GARDEN GROVE	NS	GROVE
2350	GG	WB	GARDEN GROVE	FS	NELSON
2351	GG	WB	GARDEN GROVE	FS	NUTWOOD
2352	GG	WB	GARDEN GROVE	FS	BROOKHURST
2353	GG	WB	GARDEN GROVE	NS	BROOKHURST
2354	GG	WB	GARDEN GROVE	NS	GALWAY
2355	GG	WB	GARDEN GROVE	FS	GILBERT
2356	GG	WB	GARDEN GROVE	OPP	CASA LINDA
2357	GG	WB	GARDEN GROVE	FS	LUCILLE
2358	GG	WB	GARDEN GROVE	FS	MAGNOLIA
2359	GG	WB	GARDEN GROVE	NS	JOSEPHINE
2360	GG	WB	GARDEN GROVE	FS	DALE
2361	GG	WB	GARDEN GROVE	NS	FERN
2362	GG	WB	GARDEN GROVE	FS	BEACH
2363	GG	WB	GARDEN GROVE	NS	HOOVER
2364	GG	WB	GARDEN GROVE	FS	WESTERN
2365	GG	WB	GARDEN GROVE	FS	EAGLE
2366	GG	WB	GARDEN GROVE	VFS	GOLDEN WEST
2367	GG	NB	HARBOR	OPP	WOODBURY
2368	GG	NB	HARBOR	VNS	TRASK
2369	GG	NB	HARBOR	OPP	BANNER
2370	GG	NB	HARBOR	FS	HARBOR PLACE CENTER
2371	GG	NB	HARBOR	VFS	GARDEN GROVE
2372	GG	NB	HARBOR	NS	PALM
2373	GG	NB	HARBOR	NS	LAMPSON
2374	GG	NB	HARBOR	FS	TWINTREE
2375	GG	NB	HARBOR	NS	TARGET CENTER
2376	GG	SB	HARBOR	FS	CHAPMAN
2377	GG	SB	HARBOR	FS	TWINTREE
2378	GG	SB	HARBOR	FS	LAMPSON
2379	GG	SB	HARBOR	OPP	PALM
2380	GG	SB	HARBOR	NS	BUARO
2381	GG	SB	HARBOR	FS	GARDEN GROVE
2382	GG	SB	HARBOR	NS	BANNER
2383	GG	SB	HARBOR	FS	TRASK
2384	GG	SB	HARBOR	FS	WOODBURY
2385	GG	NB	HASTER	FS	GARDEN GROVE
2386	GG	NB	HASTER	NS	BLUE SPRUCE
2387	GG	NB	HASTER	NS	LAMPSON
2388	GG	NB	HASTER	FS	ALLARD
2389	GG	NB	HASTER	FS	CHAPMAN
2390	GG	NB	HASTER	FS	TILLER
2391	GG	SB	HASTER	NS	CHAPMAN
2392	GG	SB	HASTER	FS	LAMPSON

Bus Stop Maintenance

RFP 1-3408

All Stop Locations

Exhibit A

Attachment 2

OCTA_ID	CITY	DIR	STREET_OF_TRAVEL	LOC	CROSS_STREET
2393	GG	SB	HASTER	FS	ASPENWOOD
2394	GG	SB	HASTER	OPP	BLUE SPRUCE
2395	GG	WB	HAZARD	NS	WARD
2396	GG	WB	HAZARD	FS	DEANANN
2397	GG	WB	HAZARD	FS	BROOKHURST
2398	GG	WB	HAZARD	FS	KERRY
2399	GG	EB	KATELLA	FS	DALE
2400	GG	EB	KATELLA	NS	MACMURRAY
2401	GG	EB	KATELLA	FS	MAGNOLIA
2402	GG	EB	KATELLA	OPP	GARZA
2403	GG	EB	KATELLA	FS	GILBERT
2404	GG	EB	KATELLA	FS	BARCLAY
2405	GG	EB	KATELLA	NS	BROOKHURST
2406	GG	EB	KATELLA	NS	DALLAS
2407	GG	EB	KATELLA	OPP	NUTWOOD
2408	GG	EB	KATELLA	FS	DINO
2409	GG	NB	KNOTT	FS	ACACIA
2410	GG	NB	KNOTT	OPP	STANFORD
2411	GG	NB	KNOTT	FS	LAMPSON
2412	GG	NB	KNOTT	NS	BELGRAVE
2413	GG	NB	KNOTT	NS	CHAPMAN
2414	GG	NB	KNOTT	OPP	LEILANI
2415	GG	NB	KNOTT	FS	ORANGEWOOD
2416	GG	NB	KNOTT	FS	PATTERSON
2417	GG	SB	KNOTT	FS	CHAPMAN
2418	GG	SB	KNOTT	FS	BELGRAVE
2419	GG	SB	KNOTT	FS	LAMPSON
2420	GG	SB	KNOTT	FS	STANFORD
2421	GG	SB	KNOTT	OPP	ACACIA
2422	GG	EB	LAMPSON	FS	MANLEY
2423	GG	EB	LAMPSON	FS	BLACKMER
2424	GG	EB	LAMPSON	FS	VALLEY VIEW
2425	GG	EB	LAMPSON	FS	TOPAZ
2426	GG	EB	LAMPSON	FS	SPRINGDALE
2427	GG	EB	LAMPSON	FS	LAMPLIGHTER
2428	GG	EB	LAMPSON	OPP	ENT 6851 PACIFICA
2429	GG	EB	LAMPSON	NS	KNOTT
2430	GG	EB	LAMPSON	NS	INDUSTRY
2431	GG	EB	LAMPSON	FS	MONARCH
2432	GG	EB	LAMPSON	OPP	ENT 13181 GLENHAVEN
2433	GG	EB	LAMPSON	NS	HILTON
2434	GG	WB	LAMPSON	OPP	HILTON
2435	GG	WB	LAMPSON	FS	ENT 13181 GLENHAVEN
2436	GG	WB	LAMPSON	FS	WESTERN
2437	GG	WB	LAMPSON	FS	MONARCH
2438	GG	WB	LAMPSON	FS	INDUSTRY

Bus Stop Maintenance

RFP 1-3408

All Stop Locations

Exhibit A

Attachment 2

OCTA_ID	CITY	DIR	STREET_OF_TRAVEL	LOC	CROSS_STREET
2439	GG	WB	LAMPSON	FS	KNOTT
2440	GG	WB	LAMPSON	NS	ENT 6851 PACIFICA
2441	GG	WB	LAMPSON	FS	LAMPLIGHTER
2442	GG	WB	LAMPSON	FS	SPRINGDALE
2443	GG	WB	LAMPSON	FS	TOPAZ
2444	GG	WB	LAMPSON	FS	VALLEY VIEW
2445	GG	WB	LAMPSON	FS	BLACKMER
2446	GG	WB	LAMPSON	FS	MANLEY
2447	GG	SB	LEWIS	FS	CHAPMAN
2448	GG	SB	LEWIS	OPP	CITY PKWY WEST
2449	GG	SB	LEWIS	FS	LAMPSON
2450	OR	SB	LEWIS	FS	EL PRADO
2451	GG	NB	MAGNOLIA	FS	WESTMINSTER
2452	GG	NB	MAGNOLIA	NS	MAYS
2453	GG	NB	MAGNOLIA	FS	TRASK
2454	GG	NB	MAGNOLIA	NS	IMPERIAL
2455	GG	NB	MAGNOLIA	FS	GARDEN GROVE
2456	GG	NB	MAGNOLIA	FS	STANFORD
2457	GG	NB	MAGNOLIA	FS	LAMPSON
2458	GG	NB	MAGNOLIA	NS	HEALEY
2459	GG	NB	MAGNOLIA	FS	CHAPMAN
2460	GG	NB	MAGNOLIA	NS	TRISTAN
2461	GG	NB	MAGNOLIA	FS	SHELLEY
2462	GG	NB	MAGNOLIA	FS	ORANGEWOOD
2463	GG	NB	MAGNOLIA	NS	ROSANNA
2464	GG	SB	MAGNOLIA	FS	KATELLA
2465	GG	SB	MAGNOLIA	OPP	ROSANNA
2466	GG	SB	MAGNOLIA	FS	ORANGEWOOD
2467	GG	SB	MAGNOLIA	FS	MACALPINE
2468	GG	SB	MAGNOLIA	FS	CHAPMAN
2469	GG	SB	MAGNOLIA	OPP	HEALEY
2470	GG	SB	MAGNOLIA	FS	LAMPSON
2471	GG	SB	MAGNOLIA	OPP	STANFORD
2472	GG	SB	MAGNOLIA	NS	GARDEN GROVE
2473	GG	SB	MAGNOLIA	OPP	IMPERIAL
2474	GG	SB	MAGNOLIA	NS	TRASK
2475	GG	SB	MAGNOLIA	FS	MAYS
2476	GG	EB	MCFADDEN	FS	WARD
2477	GG	NB	NEWHOPE	FS	WESTMINSTER
2478	GG	NB	NEWHOPE	OPP	WOODBURY
2479	GG	NB	NEWHOPE	FS	TRASK
2480	GG	NB	NEWHOPE	NS	PALOMA
2481	GG	NB	NEWHOPE	VNS	STUART
2482	GG	SB	NEWHOPE	FS	GARDEN GROVE
2483	GG	SB	NEWHOPE	NS	PALOMA
2484	GG	SB	NEWHOPE	NS	TRASK

Bus Stop Maintenance

RFP 1-3408

All Stop Locations

Exhibit A

Attachment 2

OCTA_ID	CITY	DIR	STREET_OF_TRAVEL	LOC	CROSS_STREET
2485	GG	SB	NEWHOPE	FS	WOODBURY
2486	GG	NB	VALLEY VIEW	OPP	TIFFANY
2487	GG	NB	VALLEY VIEW	FS	CERULEAN
2488	GG	NB	VALLEY VIEW	FS	LAMPSON
2489	GG	NB	VALLEY VIEW	OPP	BELGRAVE
2490	GG	NB	VALLEY VIEW	FS	CHAPMAN
2491	GG	NB	VALLEY VIEW	FS	SANTA BARBARA
2492	GG	SB	VALLEY VIEW	VNS	CHAPMAN
2493	GG	SB	VALLEY VIEW	FS	CHAPMAN
2494	GG	SB	VALLEY VIEW	FS	BELGRAVE
2495	GG	SB	VALLEY VIEW	FS	LAMPSON
2496	GG	SB	VALLEY VIEW	FS	CERULEAN
2497	GG	SB	VALLEY VIEW	NS	TIFFANY
2498	GG	NB	WEST	FS	GARDEN GROVE
2499	GG	NB	WEST	NS	DUNKLEE
2500	GG	NB	WEST	NS	COLLEGE
2501	GG	NB	WEST	FS	LAMPSON
2502	GG	NB	WEST	OPP	SHETLAND
2503	GG	NB	WEST	FS	CHAPMAN
2504	GG	NB	WEST	FS	REVA
2505	GG	NB	WEST	NS	WILKEN
2506	GG	SB	WEST	NS	ORANGEWOOD
2507	GG	SB	WEST	NS	DANIEL
2508	GG	SB	WEST	NS	DONNA
2509	GG	SB	WEST	NS	CHAPMAN
2510	GG	SB	WEST	NS	SHETLAND
2511	GG	SB	WEST	NS	LAMPSON
2512	GG	SB	WEST	FS	MORGAN
2513	GG	SB	WEST	OPP	DUNKLEE
2514	GG	NB	WESTERN	NS	ANTHONY
2515	GG	NB	WESTERN	FS	ACACIA
2516	GG	NB	WESTERN	VNS	LAMPSON
2517	GG	SB	WESTERN	FS	LAMPSON
2518	GG	SB	WESTERN	NS	ENT SUBARU TECHNICAL
2519	GG	SB	WESTERN	OPP	ACACIA
2520	GG	EB	WESTMINSTER	FS	BUSHARD
2521	GG	EB	WESTMINSTER	OPP	ERIN
2522	GG	EB	WESTMINSTER	FS	KERRY
2523	GG	EB	WESTMINSTER	FS	BROOKHURST
2524	GG	EB	WESTMINSTER	FS	HOPE
2525	GG	EB	WESTMINSTER	FS	BOWEN
2526	GG	EB	WESTMINSTER	FS	LAKE
2527	GG	EB	WESTMINSTER	OPP	TAFT
2528	GG	EB	WESTMINSTER	FS	CLINTON
2529	GG	EB	WESTMINSTER	FS	BUENA
2530	GG	WB	WESTMINSTER	OPP	BUENA

Bus Stop Maintenance

RFP 1-3408

All Stop Locations

Exhibit A

Attachment 2

OCTA_ID	CITY	DIR	STREET_OF_TRAVEL	LOC	CROSS_STREET
2531	GG	WB	WESTMINSTER	NS	ROXEY
2532	GG	WB	WESTMINSTER	FS	CLINTON
2533	GG	WB	WESTMINSTER	NS	HARPER
2534	GG	WB	WESTMINSTER	FS	ENTERPRISE
2535	GG	WB	WESTMINSTER	FS	HARBOR
2536	GG	WB	WESTMINSTER	FS	WEST
2537	GG	WB	WESTMINSTER	NS	A BETTER WAY
2538	GG	WB	WESTMINSTER	FS	NEWHOPE
2539	GG	WB	WESTMINSTER	FS	PARKWOOD
2540	GG	WB	WESTMINSTER	FS	ROSITA
2541	GG	WB	WESTMINSTER	FS	EUCLID
2542	GG	WB	WESTMINSTER	NS	TAFT
2543	GG	WB	WESTMINSTER	OPP	LAKE
2544	GG	WB	WESTMINSTER	FS	BOWEN
2545	GG	WB	WESTMINSTER	FS	DAWSON
2546	GG	WB	WESTMINSTER	FS	BROOKHURST
2547	GG	WB	WESTMINSTER	OPP	KERRY
2548	GG	WB	WESTMINSTER	NS	ERIN
2549	GG	WB	WESTMINSTER	OPP	BUSHARD
2550	GG	WB	WESTMINSTER	FS	ATLANTIS
2551	GG	WB	WESTMINSTER	FS	MAGNOLIA
2552	GG	WB	WESTMINSTER	FS	YOCKEY
2553	HB	NB	17TH	FS	PALM
2554	HB	NB	17TH	OPP	AGUA
2555	HB	NB	17TH	NS	ADAMS
2556	HB	SB	17TH	FS	MAIN
2557	HB	SB	17TH	OPP	ADAMS
2558	HB	SB	17TH	FS	AGUA
2559	HB	SB	17TH	NS	PALM
2560	HB	SB	17TH	FS	PECAN
2561	HB	SB	1ST	FS	ORANGE
2562	HB	EB	ADAMS	FS	MAIN
2563	HB	EB	ADAMS	FS	LAKE
2564	HB	EB	ADAMS	FS	DELAWARE
2565	HB	EB	ADAMS	FS	BEACH
2566	HB	EB	ADAMS	FS	SEABRIDGE
2567	HB	EB	ADAMS	FS	NEW BRITAIN
2568	HB	EB	ADAMS	FS	NEWLAND
2569	HB	EB	ADAMS	FS	CROWN REEF
2570	HB	EB	ADAMS	FS	MAGNOLIA
2571	HB	EB	ADAMS	NS	MARINA
2572	HB	EB	ADAMS	FS	BUSHARD
2573	HB	EB	ADAMS	FS	DERBYSHIRE
2574	HB	EB	ADAMS	NS	BROOKHURST
2575	HB	EB	ADAMS	VFS	BROOKHURST
2576	HB	EB	ADAMS	FS	LAWSON

Bus Stop Maintenance**All Stop Locations**

RFP 1-3408

Exhibit A

Attachment 2

OCTA_ID	CITY	DIR	STREET_OF_TRAVEL	LOC	CROSS_STREET
2577	HB	WB	ADAMS	FS	PICADILLAY
2578	HB	WB	ADAMS	FS	BROOKHURST
2579	HB	WB	ADAMS	FS	SUTTON
2580	HB	WB	ADAMS	FS	DERBYSHIRE
2581	HB	WB	ADAMS	FS	BUSHARD
2582	HB	WB	ADAMS	NS	LOTUS
2583	HB	WB	ADAMS	FS	MAGNOLIA
2584	HB	WB	ADAMS	FS	FELLCLIFF
2585	HB	WB	ADAMS	FS	NEWLAND
2586	HB	WB	ADAMS	FS	ROTHERT
2587	HB	WB	ADAMS	FS	COLDWATER
2588	HB	WB	ADAMS	FS	BEACH
2589	HB	WB	ADAMS	NS	DELAWARE
2590	HB	WB	ADAMS	NS	LAKE
2591	HB	WB	ADAMS	NS	MAIN
2592	HB	NB	ALGONQUIN	OPP	DAVENPORT
2593	HB	NB	ALGONQUIN	FS	PEARCE
2594	HB	NB	ALGONQUIN	NS	HEIL
2595	HB	SB	ALGONQUIN	FS	HEIL
2596	HB	SB	ALGONQUIN	FS	BOARDWALK
2597	HB	EB	ATLANTA	FS	HUNTINGTON
2598	HB	EB	ATLANTA	FS	ADMIRAL
2599	HB	EB	ATLANTA	FS	BEACH
2600	HB	EB	ATLANTA	FS	NEWLAND
2601	HB	EB	ATLANTA	FS	MIRAMAR
2602	HB	WB	ATLANTA	FS	MAGNOLIA
2603	HB	WB	ATLANTA	NS	GREENFIELD
2604	HB	WB	ATLANTA	FS	NEWLAND
2605	HB	WB	ATLANTA	FS	SCHOONER
2606	HB	WB	ATLANTA	FS	BEACH
2607	HB	WB	ATLANTA	NS	DELAWARE
2608	HB	WB	ATLANTA	NS	HUNTINGTON
2609	HB	NB	BEACH	FS	PACIFIC COAST
2610	HB	NB	BEACH	FS	SUNRISE
2611	HB	NB	BEACH	FS	ATLANTA
2612	HB	NB	BEACH	FS	INDIANAPOLIS
2613	HB	NB	BEACH	FS	SEABRIDGE
2614	HB	NB	BEACH	FS	ADAMS
2615	HB	NB	BEACH	FS	UTICA
2616	HB	NB	BEACH	FS	YORKTOWN
2617	HB	NB	BEACH	OPP	CLAY
2618	HB	NB	BEACH	FS	GARFIELD
2619	HB	NB	BEACH	FS	GRAZIADIO
2620	HB	NB	BEACH	FS	ELLIS
2621	HB	NB	BEACH	OPP	TAYLOR
2622	HB	NB	BEACH	FS	TALBERT

Bus Stop Maintenance

RFP 1-3408

All Stop Locations

Exhibit A

Attachment 2

OCTA_ID	CITY	DIR	STREET_OF_TRAVEL	LOC	CROSS_STREET
2623	HB	NB	BEACH	NS	NEWMAN
2624	HB	NB	BEACH	NS	SLATER
2625	HB	NB	BEACH	FS	HOLLAND
2626	HB	NB	BEACH	NS	BLAYLOCK
2627	HB	NB	BEACH	FS	WARNER
2628	HB	NB	BEACH	FS	TERRY
2629	HB	SB	BEACH	NS	STARK
2630	HB	SB	BEACH	NS	MACDONALD
2631	HB	SB	BEACH	FS	HEIL
2632	HB	SB	BEACH	FS	TERRY
2633	HB	SB	BEACH	FS	WARNER
2634	HB	SB	BEACH	FS	CYPRESS
2635	HB	SB	BEACH	OPP	HOLLAND
2636	HB	SB	BEACH	FS	SLATER
2637	HB	SB	BEACH	FS	LIBERTY
2638	HB	SB	BEACH	FS	TALBERT
2639	HB	SB	BEACH	FS	TAYLOR
2640	HB	SB	BEACH	FS	MAIN
2641	HB	SB	BEACH	OPP	CONSTANTINE
2642	HB	SB	BEACH	FS	GARFIELD
2643	HB	SB	BEACH	FS	CLAY
2644	HB	SB	BEACH	FS	YORKTOWN
2645	HB	SB	BEACH	FS	UTICA
2646	HB	SB	BEACH	FS	ADAMS
2647	HB	SB	BEACH	NS	MEMPHIS
2648	HB	SB	BEACH	NS	INDIANAPOLIS
2649	HB	SB	BEACH	OPP	SUNSET
2650	HB	SB	BEACH	FS	ATLANTA
2651	HB	SB	BEACH	NS	SUNRISE
2652	HB	SB	BEACH	FS	PACIFIC COAST
2653	HB	EB	BOLSA	FS	BOLSA CHICA
2654	HB	EB	BOLSA	VFS	BOLSA CHICA
2655	HB	EB	BOLSA	VNS	GRAHAM
2656	HB	EB	BOLSA	NS	GRAHAM
2657	HB	EB	BOLSA	VFS	SPRINGDALE
2658	HB	EB	BOLSA	NS	CAPETOWN
2659	HB	EB	BOLSA	FS	DRAKE
2660	HB	EB	BOLSA	FS	EDWARDS
2661	HB	EB	BOLSA	FS	VICTORIA
2662	HB	EB	BOLSA	NS	GOLDEN WEST
2663	HB	WB	BOLSA	OPP	GRAHAM
2664	HB	WB	BOLSA	NS	ENT 5301 BOEING
2665	HB	WB	BOLSA	VNS	BOLSA CHICA
2666	HB	NB	BOLSA CHICA	FS	WARNER
2667	HB	NB	BOLSA CHICA	FS	PEARCE
2668	HB	NB	BOLSA CHICA	FS	HEIL

Bus Stop Maintenance

RFP 1-3408

All Stop Locations

Exhibit A

Attachment 2

OCTA_ID	CITY	DIR	STREET_OF_TRAVEL	LOC	CROSS_STREET
2669	HB	NB	BOLSA CHICA	FS	SISSON
2670	HB	NB	BOLSA CHICA	NS	EDINGER
2671	HB	NB	BOLSA CHICA	VFS	BOLSA
2672	HB	SB	BOLSA CHICA	FS	EDINGER
2673	HB	SB	BOLSA CHICA	FS	OAHU
2674	HB	SB	BOLSA CHICA	FS	HEIL
2675	HB	SB	BOLSA CHICA	FS	PEARCE
2676	HB	NB	BROOKHURST	OPP	BUSHARD
2677	HB	NB	BROOKHURST	FS	ENT COUNTY SANITATION
2678	HB	NB	BROOKHURST	OPP	BANNING
2679	HB	NB	BROOKHURST	OPP	BAYBREEZE
2680	HB	NB	BROOKHURST	VNS	HAMILTON
2681	HB	NB	BROOKHURST	FS	HAMILTON
2682	HB	NB	BROOKHURST	OPP	VILLA PACIFIC
2683	HB	NB	BROOKHURST	OPP	EFFINGHAM
2684	HB	NB	BROOKHURST	NS	SPRIT
2685	HB	NB	BROOKHURST	FS	ATLANTA
2686	HB	NB	BROOKHURST	FS	CLIFF
2687	HB	NB	BROOKHURST	OPP	INDIANAPOLIS
2688	HB	NB	BROOKHURST	@	STONYBROOK
2689	HB	NB	BROOKHURST	FS	MEREDITH
2690	HB	NB	BROOKHURST	FS	ADAMS
2691	HB	NB	BROOKHURST	FS	CONSTITUTION
2692	HB	NB	BROOKHURST	FS	YORKTOWN
2693	HB	NB	BROOKHURST	NS	KAMUELA
2694	HB	NB	BROOKHURST	FS	KUKUI
2695	HB	SB	BROOKHURST	FS	GARFIELD
2696	HB	SB	BROOKHURST	OPP	KUKUI
2697	HB	SB	BROOKHURST	NS	ENT 19361 RANCHO MOBILE
2698	HB	SB	BROOKHURST	FS	YORKTOWN
2699	HB	SB	BROOKHURST	FS	CONSTITUTION
2700	HB	SB	BROOKHURST	FS	CONTINENTAL
2701	HB	SB	BROOKHURST	VFS	ADAMS
2702	HB	SB	BROOKHURST	FS	PECK
2703	HB	SB	BROOKHURST	FS	INDIANAPOLIS
2704	HB	SB	BROOKHURST	OPP	CLIFF
2705	HB	SB	BROOKHURST	FS	ENDEVER
2706	HB	SB	BROOKHURST	FS	ATLANTA
2707	HB	SB	BROOKHURST	FS	EFFINGHAM
2708	HB	SB	BROOKHURST	NS	VILLA PACIFIC
2709	HB	SB	BROOKHURST	FS	HAMILTON
2710	HB	SB	BROOKHURST	VFS	HAMILTON
2711	HB	SB	BROOKHURST	FS	BAYBREEZE
2712	HB	SB	BROOKHURST	FS	BANNING
2713	HB	SB	BROOKHURST	OPP	ENT COUNTY SANITATION
2714	HB	SB	BROOKHURST	FS	BUSHARD

Bus Stop Maintenance

RFP 1-3408

All Stop Locations

Exhibit A

Attachment 2

OCTA_ID	CITY	DIR	STREET_OF_TRAVEL	LOC	CROSS_STREET
2715	HB	SB	BROOKHURST	FS	PACIFIC COAST
2716	HB	EB	CENTER	FS	GOTHARD
2717	HB	EB	CENTER	NS	BELLA TERRA
2718	HB	EB	CENTER	FS	HUNTINGTON CENTER
2719	HB	WB	CENTER	FS	ONE PACIFIC PLAZA
2720	HB	WB	CENTER	FS	HUNTINGTON VILLAGE
2721	HB	EB	DAVENPORT	FS	COURTNEY
2722	HB	NB	DELAWARE	FS	ATLANTA
2723	HB	NB	DELAWARE	NS	FRANKFORT
2724	HB	NB	DELAWARE	NS	INDIANAPOLIS
2725	HB	NB	DELAWARE	FS	KNOXVILLE
2726	HB	NB	DELAWARE	FS	MEMPHIS
2727	HB	NB	DELAWARE	NS	ADAMS
2728	HB	NB	DELAWARE	VFS	YORKTOWN
2729	HB	NB	DELAWARE	FS	CLAY
2730	HB	NB	DELAWARE	NS	GARFIELD
2731	HB	SB	DELAWARE	VFS	GARFIELD
2732	HB	SB	DELAWARE	NS	17TH
2733	HB	SB	DELAWARE	NS	YORKTOWN
2734	HB	SB	DELAWARE	OPP	OCEAN HILL
2735	HB	SB	DELAWARE	FS	MEMPHIS
2736	HB	SB	DELAWARE	FS	KNOXVILLE
2737	HB	SB	DELAWARE	NS	INDIANAPOLIS
2738	HB	SB	DELAWARE	NS	FRANKFORT
2739	HB	SB	DELAWARE	NS	BAY
2740	HB	EB	EDINGER	FS	BOLSA CHICA
2741	HB	EB	EDINGER	FS	WARREN
2742	HB	EB	EDINGER	NS	GRAHAM
2743	HB	EB	EDINGER	NS	CLUBHOUSE
2744	HB	EB	EDINGER	NS	SPRINGDALE
2745	HB	EB	EDINGER	OPP	PLYMOUTH
2746	HB	EB	EDINGER	OPP	STANDISH
2747	HB	EB	EDINGER	FS	EDWARDS
2748	HB	EB	EDINGER	OPP	BELFAST
2749	HB	EB	EDINGER	FS	MARJAN
2750	HB	EB	EDINGER	FS	GOLDEN WEST
2751	HB	EB	EDINGER	NS	ENT 7222 CALIFORNIA
2752	HB	EB	EDINGER	FS	GOTHARD
2753	HB	EB	EDINGER	FS	ENT 7552 CITICORP SAVINGS
2754	HB	EB	EDINGER	FS	SHER
2755	HB	EB	EDINGER	NS	PARKSIDE
2756	HB	EB	EDINGER	VNS	NEWLAND
2757	HB	WB	EDINGER	FS	BEACH
2758	HB	WB	EDINGER	OPP	SHER
2759	HB	WB	EDINGER	VNS	GOTHARD
2760	HB	WB	EDINGER	FS	GOTHARD

Bus Stop Maintenance

RFP 1-3408

All Stop Locations

Exhibit A

Attachment 2

OCTA_ID	CITY	DIR	STREET_OF_TRAVEL	LOC	CROSS_STREET
2761	HB	WB	EDINGER	VNS	GOLDEN WEST
2762	HB	WB	EDINGER	FS	GOLDEN WEST
2763	HB	WB	EDINGER	FS	SHERBECK
2764	HB	WB	EDINGER	FS	EDWARDS
2765	HB	WB	EDINGER	FS	STANDISH
2766	HB	WB	EDINGER	FS	PLYMOUTH
2767	HB	WB	EDINGER	FS	SPRINGDALE
2768	HB	WB	EDINGER	OPP	CLUBHOUSE
2769	HB	WB	EDINGER	NS	GRAHAM
2770	HB	WB	EDINGER	FS	BOLSA CHICA
2771	HB	WB	EDINGER	OPP	MELODY
2772	HB	WB	EDINGER	OPP	FANTASIA
2773	HB	WB	EDINGER	OPP	MONTEREY
2774	HB	SB	EDWARDS	FS	ROYAL OAK
2775	HB	SB	EDWARDS	NS	ALEXANDRIA
2776	HB	SB	EDWARDS	FS	CORNELL
2777	HB	NB	EDWARDS	FS	MCFADDEN
2778	HB	NB	EDWARDS	OPP	CORNELL
2779	HB	NB	EDWARDS	NS	BOLSA
2780	HB	EB	FRANKFORT	FS	LAKE
2781	HB	EB	FRANKFORT	FS	HUNTINGTON
2782	HB	WB	FRANKFORT	FS	DELAWARE
2783	HB	WB	FRANKFORT	FS	HUNTINGTON
2784	HB	WB	FRANKFORT	NS	LAKE
2785	HB	EB	GARFIELD	FS	GOLDEN WEST
2786	HB	EB	GARFIELD	FS	GOTHARD
2787	HB	EB	GARFIELD	FS	FLORIDA
2788	HB	EB	GARFIELD	VFS	BEACH
2789	HB	EB	GARFIELD	NS	SUMMERFIELD
2790	HB	EB	GARFIELD	NS	NEWLAND
2791	HB	EB	GARFIELD	NS	PLUM TREE
2792	HB	EB	GARFIELD	NS	LINDSAY
2793	HB	EB	GARFIELD	FS	MAGNOLIA
2794	HB	EB	GARFIELD	FS	RANDI
2795	HB	EB	GARFIELD	FS	PAULINE
2796	HB	EB	GARFIELD	FS	BUSHARD
2797	HB	EB	GARFIELD	OPP	PERSIMMON
2798	HB	EB	GARFIELD	OPP	MOUNT WALTON
2799	HB	WB	GARFIELD	FS	NEWLAND
2800	HB	WB	GARFIELD	FS	MORA-KAI
2801	HB	WB	GARFIELD	FS	BEACH
2802	HB	WB	GARFIELD	VNS	DELAWARE
2803	HB	NB	GOLDEN WEST	FS	PALM
2804	HB	NB	GOLDEN WEST	FS	DEEP HARBOR
2805	HB	NB	GOLDEN WEST	FS	YORKTOWN
2806	HB	NB	GOLDEN WEST	FS	SUMMIT

Bus Stop Maintenance

RFP 1-3408

All Stop Locations

Exhibit A

Attachment 2

OCTA_ID	CITY	DIR	STREET_OF_TRAVEL	LOC	CROSS_STREET
2807	HB	NB	GOLDEN WEST	FS	GARFIELD
2808	HB	NB	GOLDEN WEST	FS	ERNEST
2809	HB	NB	GOLDEN WEST	FS	ELLIS
2810	HB	NB	GOLDEN WEST	OPP	ENT 18381 HUNTINGTON
2811	HB	NB	GOLDEN WEST	FS	ENT HUNTINGTON BEACH
2812	HB	NB	GOLDEN WEST	OPP	RIO VISTA
2813	HB	NB	GOLDEN WEST	FS	SLATER
2814	HB	NB	GOLDEN WEST	FS	BETTY
2815	HB	NB	GOLDEN WEST	FS	WARNER
2816	HB	NB	GOLDEN WEST	NS	NORMA
2817	HB	NB	GOLDEN WEST	FS	HEIL
2818	HB	NB	GOLDEN WEST	FS	VALENTINE
2819	HB	NB	GOLDEN WEST	FS	STONEWOOD
2820	HB	NB	GOLDEN WEST	FS	EDINGER
2821	HB	NB	GOLDEN WEST	FS	ENT 15744 GOLDENWEST
2822	HB	SB	GOLDEN WEST	FS	BOLSA
2823	HB	SB	GOLDEN WEST	NS	OXFORD
2824	HB	SB	GOLDEN WEST	NS	BRUNSWICK
2825	HB	SB	GOLDEN WEST	FS	MCFADDEN
2826	HB	SB	GOLDEN WEST	OPP	ENT 15744 GOLDENWEST
2827	HB	SB	GOLDEN WEST	FS	EDINGER
2828	HB	SB	GOLDEN WEST	FS	LAURELHURST
2829	HB	SB	GOLDEN WEST	FS	HEIL
2830	HB	SB	GOLDEN WEST	FS	LYDIA
2831	HB	SB	GOLDEN WEST	FS	WARNER
2832	HB	SB	GOLDEN WEST	FS	TUCANA
2833	HB	SB	GOLDEN WEST	NS	FORD
2834	HB	SB	GOLDEN WEST	FS	SLATER
2835	HB	SB	GOLDEN WEST	FS	RIO VISTA
2836	HB	SB	GOLDEN WEST	OPP	ENT HUNTINGTON BEACH
2837	HB	SB	GOLDEN WEST	FS	ENT 7111 HUNTINGTON
2838	HB	SB	GOLDEN WEST	FS	ELLIS
2839	HB	SB	GOLDEN WEST	OPP	ERNEST
2840	HB	SB	GOLDEN WEST	FS	GARFIELD
2841	HB	SB	GOLDEN WEST	FS	SUMMIT
2842	HB	SB	GOLDEN WEST	OPP	YORKTOWN
2843	HB	SB	GOLDEN WEST	NS	DEEP HARBOR
2844	HB	NB	GOTHARD	FS	TALBERT
2845	HB	NB	GOTHARD	FS	BELVA
2846	HB	NB	GOTHARD	FS	EDINGER
2847	HB	SB	GOTHARD	FS	MCFADDEN
2848	HB	SB	GOTHARD	OPP	CENTER
2849	HB	NB	GRAHAM	FS	EDINGER
2850	HB	NB	GRAHAM	FS	RESEARCH
2851	HB	NB	GRAHAM	FS	MCFADDEN
2852	HB	NB	GRAHAM	OPP	BUSINESS

Bus Stop Maintenance**All Stop Locations**

RFP 1-3408

Exhibit A

Attachment 2

OCTA_ID	CITY	DIR	STREET_OF_TRAVEL	LOC	CROSS_STREET
2853	HB	NB	GRAHAM	OPP	ARGOSY
2854	HB	NB	GRAHAM	FS	SLATER
2855	HB	SB	GRAHAM	FS	OCEANUS
2856	HB	SB	GRAHAM	FS	BUSINESS
2857	HB	SB	GRAHAM	FS	MCFADDEN
2858	HB	SB	GRAHAM	FS	RESEARCH
2859	HB	SB	GRAHAM	NS	EDINGER
2860	HB	SB	GRAHAM	FS	WARNER
2861	HB	EB	HAMILTON	FS	MAGNOLIA
2862	HB	EB	HAMILTON	FS	POLYNESIAN
2863	HB	EB	HAMILTON	FS	LEHUA
2864	HB	EB	HAMILTON	FS	BUSHARD
2865	HB	EB	HAMILTON	OPP	VIA STRAITS
2866	HB	EB	HAMILTON	FS	BROOKHURST
2867	HB	WB	HAMILTON	FS	BROOKHURST
2868	HB	WB	HAMILTON	FS	VIA STRAITS
2869	HB	WB	HAMILTON	FS	BUSHARD
2870	HB	WB	HAMILTON	FS	NORTHSHORE
2871	HB	WB	HAMILTON	OPP	POLYNESIAN
2872	HB	EB	HEIL	FS	LE GRANDE
2873	HB	EB	HEIL	OPP	WATERWAY
2874	HB	WB	HEIL	FS	BOLSA CHICA
2875	HB	WB	HEIL	FS	WATERWAY
2876	HB	WB	HEIL	FS	LA VILLA
2877	HB	NB	HUNTINGTON	FS	PACIFIC COAST
2878	HB	NB	MAGNOLIA	FS	PACIFIC COAST
2879	HB	NB	MAGNOLIA	FS	BANNING
2880	HB	NB	MAGNOLIA	FS	BERMUDA
2881	HB	NB	MAGNOLIA	FS	HAMILTON
2882	HB	NB	MAGNOLIA	OPP	STILWELL
2883	HB	NB	MAGNOLIA	FS	ATLANTA
2884	HB	NB	MAGNOLIA	FS	CARROLLTOWN
2885	HB	NB	MAGNOLIA	NS	ELLSWORTH
2886	HB	NB	MAGNOLIA	FS	INDIANAPOLIS
2887	HB	NB	MAGNOLIA	FS	VILLAGE
2888	HB	NB	MAGNOLIA	NS	MEDITERRANEAN
2889	HB	NB	MAGNOLIA	FS	ADAMS
2890	HB	NB	MAGNOLIA	FS	PIONEER
2891	HB	NB	MAGNOLIA	NS	MADELINE
2892	HB	NB	MAGNOLIA	FS	YORKTOWN
2893	HB	NB	MAGNOLIA	NS	MOORPARK
2894	HB	NB	MAGNOLIA	NS	HYDE PARK
2895	HB	SB	MAGNOLIA	FS	GARFIELD
2896	HB	SB	MAGNOLIA	OPP	HYDE PARK
2897	HB	SB	MAGNOLIA	NS	SEAHURST
2898	HB	SB	MAGNOLIA	FS	YORKTOWN

Bus Stop Maintenance**All Stop Locations**

RFP 1-3408

Exhibit A

Attachment 2

OCTA_ID	CITY	DIR	STREET_OF_TRAVEL	LOC	CROSS_STREET
2899	HB	SB	MAGNOLIA	OPP	MADELINE
2900	HB	SB	MAGNOLIA	OPP	PIONEER
2901	HB	SB	MAGNOLIA	FS	ADAMS
2902	HB	SB	MAGNOLIA	FS	MEDITERRANEAN
2903	HB	SB	MAGNOLIA	NS	BEDEL
2904	HB	SB	MAGNOLIA	FS	INDIANAPOLIS
2905	HB	SB	MAGNOLIA	OPP	CARROLLTOWN
2906	HB	SB	MAGNOLIA	FS	ATLANTA
2907	HB	SB	MAGNOLIA	NS	STILWELL
2908	HB	SB	MAGNOLIA	VNS	HAMILTON
2909	HB	SB	MAGNOLIA	NS	HAMILTON
2910	HB	SB	MAGNOLIA	OPP	BERMUDA
2911	HB	SB	MAGNOLIA	OPP	BANNING
2912	HB	SB	MAGNOLIA	FS	PACIFIC COAST
2913	HB	NB	MAIN	FS	ACACIA
2914	HB	NB	MAIN	FS	CREST
2915	HB	NB	MAIN	NS	12TH
2916	HB	NB	MAIN	NS	13TH
2917	HB	NB	MAIN	FS	ADAMS
2918	HB	NB	MAIN	FS	SPRINGFIELD
2919	HB	NB	MAIN	FS	UTICA
2920	HB	NB	MAIN	NS	YORKTOWN
2921	HB	NB	MAIN	FS	GARFIELD
2922	HB	NB	MAIN	FS	HUNTINGTON
2923	HB	NB	MAIN	FS	DELAWARE
2924	HB	NB	MAIN	FS	FLORIDA
2925	HB	SB	MAIN	FS	ELLIS
2926	HB	SB	MAIN	OPP	FLORIDA
2927	HB	SB	MAIN	FS	DELAWARE
2928	HB	SB	MAIN	NS	HUNTINGTON
2929	HB	SB	MAIN	FS	GARFIELD
2930	HB	SB	MAIN	FS	GOTHARD
2931	HB	SB	MAIN	FS	YORKTOWN
2932	HB	SB	MAIN	FS	17TH
2933	HB	SB	MAIN	FS	ADAMS
2934	HB	SB	MAIN	NS	13TH
2935	HB	SB	MAIN	OPP	11TH
2936	HB	SB	MAIN	FS	CREST
2937	HB	SB	MAIN	FS	7TH
2938	HB	EB	MCFADDEN	OPP	ANDAMAN
2939	HB	EB	MCFADDEN	FS	CHEMICAL
2940	HB	EB	MCFADDEN	FS	COMPUTER
2941	HB	EB	MCFADDEN	FS	PRODUCT
2942	HB	EB	MCFADDEN	NS	SPRINGDALE
2943	HB	EB	MCFADDEN	OPP	LA SALLE
2944	HB	EB	MCFADDEN	FS	EDWARDS

Bus Stop Maintenance

RFP 1-3408

All Stop Locations

Exhibit A

Attachment 2

OCTA_ID	CITY	DIR	STREET_OF_TRAVEL	LOC	CROSS_STREET
2945	HB	EB	MCFADDEN	NS	DAWSON
2946	HB	EB	MCFADDEN	FS	GOLDEN WEST
2947	HB	EB	MCFADDEN	OPP	VASSAR
2948	HB	EB	MCFADDEN	FS	GRAHAM
2949	HB	EB	MCFADDEN	FS	GOTHARD
2950	HB	WB	MCFADDEN	FS	GOLDEN WEST
2951	HB	WB	MCFADDEN	@	VICTORIA
2952	HB	WB	MCFADDEN	FS	EDWARDS
2953	HB	WB	MCFADDEN	NS	LA SALLE
2954	HB	WB	MCFADDEN	NS	HOLIDAY
2955	HB	WB	MCFADDEN	FS	SPRINGDALE
2956	HB	WB	MCFADDEN	FS	ELECTRONIC
2957	HB	WB	MCFADDEN	OPP	COMPUTER
2958	HB	EB	ORANGE	FS	17TH
2959	HB	EB	ORANGE	NS	14TH
2960	HB	EB	ORANGE	NS	12TH
2961	HB	EB	ORANGE	NS	9TH
2962	HB	EB	ORANGE	FS	7TH
2963	HB	EB	ORANGE	FS	MAIN
2964	HB	EB	ORANGE	NS	1ST
2965	HB	WB	ORANGE	OPP	1ST
2966	HB	WB	ORANGE	NS	MAIN
2967	HB	WB	ORANGE	FS	MAIN
2968	HB	WB	ORANGE	NS	9TH
2969	HB	WB	ORANGE	NS	12TH
2970	HB	WB	ORANGE	FS	14TH
2971	HB	WB	ORANGE	NS	17TH
2972	HB	NB	PACIFIC COAST	FS	BROOKHURST
2973	HB	NB	PACIFIC COAST	FS	MAGNOLIA
2974	HB	NB	PACIFIC COAST	FS	NEWLAND
2975	HB	NB	PACIFIC COAST	FS	BEACH
2976	HB	NB	PACIFIC COAST	VFS	BEACH
2977	HB	NB	PACIFIC COAST	FS	HUNTINGTON
2978	HB	NB	PACIFIC COAST	VNS	1ST
2979	HB	NB	PACIFIC COAST	FS	1ST
2980	HB	NB	PACIFIC COAST	NS	MAIN
2981	HB	NB	PACIFIC COAST	FS	6TH
2982	HB	NB	PACIFIC COAST	NS	9TH
2983	HB	NB	PACIFIC COAST	NS	11TH
2984	HB	NB	PACIFIC COAST	NS	14TH
2985	HB	NB	PACIFIC COAST	NS	17TH
2986	HB	NB	PACIFIC COAST	FS	GOLDEN WEST
2987	HB	NB	PACIFIC COAST	FS	WARNER
2988	HB	NB	PACIFIC COAST	FS	CORAL CAY
2989	OC	NB	PACIFIC COAST	FS	BROADWAY
2990	HB	NB	PACIFIC COAST	FS	ADMIRALTY

Bus Stop Maintenance

RFP 1-3408

All Stop Locations

Exhibit A

Attachment 2

OCTA_ID	CITY	DIR	STREET_OF_TRAVEL	LOC	CROSS_STREET
2991	HB	NB	PACIFIC COAST	OPP	24TH
2992	HB	NB	PACIFIC COAST	FS	ANDERSON
2993	SB	NB	PACIFIC COAST	FS	MARINER
2994	HB	SB	PACIFIC COAST	OPP	SEAPOINT
2995	HB	SB	PACIFIC COAST	OPP	GOLDEN WEST
2996	HB	SB	PACIFIC COAST	OPP	17TH
2997	HB	SB	PACIFIC COAST	OPP	14TH
2998	HB	SB	PACIFIC COAST	OPP	11TH
2999	HB	SB	PACIFIC COAST	OPP	8TH
3000	HB	SB	PACIFIC COAST	OPP	MAIN
3001	HB	SB	PACIFIC COAST	OPP	2ND
3002	HB	SB	PACIFIC COAST	OPP	1ST
3003	HB	SB	PACIFIC COAST	OPP	1ST
3004	HB	SB	PACIFIC COAST	OPP	1ST
3005	HB	SB	PACIFIC COAST	OPP	HUNTINGTON
3006	HB	SB	PACIFIC COAST	VNS	BEACH
3007	HB	SB	PACIFIC COAST	VFS	BEACH
3008	HB	SB	PACIFIC COAST	VFS	NEWLAND
3009	HB	SB	PACIFIC COAST	VFS	MAGNOLIA
3010	HB	SB	PACIFIC COAST	VFS	BROOKHURST
3011	HB	EB	PALM	FS	GOLDEN WEST
3012	HB	EB	PALM	NS	17TH
3013	HB	WB	PALM	FS	17TH
3014	HB	WB	PALM	OPP	20TH
3015	HB	SB	SAYBROOK	FS	EDINGER
3016	HB	SB	SAYBROOK	FS	HUMBOLT
3017	HB	SB	SAYBROOK	FS	FISHER
3018	HB	SB	SAYBROOK	NS	MORNING STAR
3019	HB	SB	SAYBROOK	NS	SILLIMAN
3020	HB	EB	SLATER	FS	GRAHAM
3021	HB	EB	SLATER	FS	METZLER
3022	HB	EB	SLATER	FS	MORGAN
3023	HB	NB	SPRINGDALE	FS	SLATER
3024	HB	NB	SPRINGDALE	FS	MCFADDEN
3025	HB	NB	SPRINGDALE	OPP	MACHINE
3026	HB	NB	SPRINGDALE	NS	THOR
3027	HB	SB	SPRINGDALE	FS	BOLSA
3028	HB	SB	SPRINGDALE	FS	ENGINEER
3029	HB	SB	SPRINGDALE	FS	MACHINE
3030	HB	SB	SPRINGDALE	FS	WARNER
3031	HB	SB	SPRINGDALE	NS	SLATER
3032	HB	EB	TALBERT	FS	BEACH
3033	HB	EB	TALBERT	VFS	BEACH
3034	HB	WB	TALBERT	OPP	HARTLUND
3035	HB	WB	TALBERT	FS	BEACH
3036	HB	WB	TALBERT	FS	BROOKSHIRE

Bus Stop Maintenance
All Stop Locations

RFP 1-3408
Exhibit A
Attachment 2

OCTA_ID	CITY	DIR	STREET_OF_TRAVEL	LOC	CROSS_STREET
3037	HB	WB	TALBERT	FS	LYONS
3038	OC	EB	WARNER	VFS	PACIFIC COAST
3039	HB	EB	WARNER	VFS	LOS PATOS
3040	HB	EB	WARNER	FS	LYNN
3041	HB	EB	WARNER	FS	GREEN
3042	HB	EB	WARNER	FS	BOLSA CHICA
3043	HB	EB	WARNER	FS	LESLIE
3044	HB	EB	WARNER	FS	GRAHAM
3045	HB	EB	WARNER	FS	REMINGTON
3046	HB	EB	WARNER	FS	SPRINGDALE
3047	HB	EB	WARNER	NS	ENT 6242 CALIFORNIAN APTS
3048	HB	EB	WARNER	FS	EDWARDS
3049	HB	EB	WARNER	OPP	SCULPIN
3050	HB	EB	WARNER	FS	GOLDEN WEST
3051	HB	EB	WARNER	NS	GOTHARD
3052	HB	EB	WARNER	NS	NICHOLS
3053	HB	EB	WARNER	NS	OAK
3054	HB	EB	WARNER	NS	BEACH
3055	HB	EB	WARNER	FS	ROTTERDAM
3056	HB	WB	WARNER	FS	MAGNOLIA
3057	HB	WB	WARNER	NS	ROSS
3058	HB	WB	WARNER	FS	NEWLAND
3059	HB	WB	WARNER	OPP	ROTTERDAM
3060	HB	WB	WARNER	FS	BEACH
3061	HB	WB	WARNER	OPP	OAK
3062	HB	WB	WARNER	FS	NICHOLS
3063	HB	WB	WARNER	FS	GOTHARD
3064	HB	WB	WARNER	VNS	GOLDEN WEST
3065	HB	WB	WARNER	FS	GOLDEN WEST
3066	HB	WB	WARNER	NS	SCULPIN
3067	HB	WB	WARNER	FS	EDWARDS
3068	HB	WB	WARNER	OPP	PINEHURST
3069	HB	WB	WARNER	FS	SPRINGDALE
3070	HB	WB	WARNER	FS	LARK
3071	HB	WB	WARNER	FS	GRAHAM
3072	HB	WB	WARNER	OPP	LESLIE
3073	HB	WB	WARNER	FS	BOLSA CHICA
3074	HB	WB	WARNER	FS	LYNN
3075	HB	WB	WARNER	NS	SIMS
3076	HB	WB	WARNER	FS	ALGONQUIN
3077	HB	WB	WARNER	FS	EDGEWATER
3078	HB	WB	WARNER	FS	SCEPTRE
3079	HB	EB	YORKTOWN	FS	GOLDEN WEST
3080	HB	EB	YORKTOWN	FS	MAIN
3081	HB	EB	YORKTOWN	FS	LAKE
3082	HB	EB	YORKTOWN	FS	HUNTINGTON

Bus Stop Maintenance

All Stop Locations

RFP 1-3408

Exhibit A

Attachment 2

OCTA_ID	CITY	DIR	STREET_OF_TRAVEL	LOC	CROSS_STREET
3083	HB	WB	YORKTOWN	FS	HUNTINGTON
3084	HB	WB	YORKTOWN	FS	PACIFIC RANCH
3085	HB	WB	YORKTOWN	FS	MAIN
3086	HB	WB	BOEING	@	BUS SHELTER
3087	HB	SB	GWTC	@	DOCK 1
3088	HB	SB	GWTC	@	DOCK 2
3089	HB	SB	GWTC	@	DOCK 3
3090	HB	SB	GWTC	@	DOCK 4
3091	HB	SB	GWTC	@	DOCK 5
3092	HB	SB	GWTC	@	DOCK 6
3093	HB	SB	GWTC	@	DOCK 7
3094	HB	SB	GWTC	@	DOCK 8
3095	HB	SB	GWTC	@	DOCK 9
3096	HB	SB	GWTC	@	DOCK 10
3097	HG	SB	BLOOMFIELD	OPP	CARDIFF
3098	HG	EB	CARSON	FS	NORWALK
3099	HG	EB	CARSON	OPP	CLARETTA
3100	HG	EB	CARSON	FS	HAWAIIAN
3101	HG	EB	CARSON	OPP	BLOOMFIELD
3102	HG	WB	CARSON	FS	BLOOMFIELD
3103	HG	WB	CARSON	FS	CLARETTA
3104	HG	WB	CIVIC CENTER	FS	NORWALK
3105	HG	NB	NORWALK	NS	221ST
3106	HG	NB	NORWALK	OPP	CIVIC CENTER
3107	HG	SB	NORWALK	NS	CIVIC CENTER
3108	HG	SB	NORWALK	FS	221ST
3109	HG	SB	NORWALK	FS	226TH
3110	IRV	NB	ADA	FS	ALTON
3111	IRV	SB	ADA	FS	BARRANCA
3112	IRV	EB	ALTON	FS	RED HILL
3113	IRV	EB	ALTON	OPP	ASTON
3114	IRV	EB	ALTON	OPP	ARMSTRONG
3115	IRV	EB	ALTON	NS	DEWAR
3116	IRV	EB	ALTON	FS	VON KARMAN
3117	IRV	EB	ALTON	FS	ENT KENDALL MCGAW LABS
3118	IRV	EB	ALTON	OPP	MILLIKAN
3119	IRV	EB	ALTON	FS	JAMBOREE
3120	IRV	EB	ALTON	FS	MURPHY
3121	IRV	EB	ALTON	FS	HARVARD
3122	IRV	EB	ALTON	FS	PASEO WESTPARK
3123	IRV	EB	ALTON	FS	SAN MARINO
3124	IRV	EB	ALTON	FS	CULVER
3125	IRV	EB	ALTON	FS	WEST YALE LOOP
3126	IRV	EB	ALTON	FS	LAKE
3127	IRV	EB	ALTON	FS	CREEK
3128	IRV	EB	ALTON	OPP	ENT 5051 CEDAR CREEK

Bus Stop Maintenance

RFP 1-3408

All Stop Locations

Exhibit A

Attachment 2

OCTA_ID	CITY	DIR	STREET_OF_TRAVEL	LOC	CROSS_STREET
3129	IRV	EB	ALTON	FS	EAST YALE LOOP
3130	IRV	EB	ALTON	NS	JEFFREY
3131	IRV	EB	ALTON	FS	ROYAL OAK
3132	IRV	EB	ALTON	FS	VALLEY OAK
3133	IRV	EB	ALTON	FS	SAND CANYON
3134	IRV	EB	ALTON	FS	PERMANENTE
3135	IRV	EB	ALTON	FS	LAGUNA CANYON
3136	IRV	EB	ALTON	FS	TELEMETRY
3137	IRV	EB	ALTON	FS	PACIFICA
3138	IRV	EB	ALTON	FS	IRVINE CENTER
3139	IRV	EB	ALTON	FS	TECHNOLOGY
3140	IRV	EB	ALTON	FS	ADA
3141	IRV	EB	ALTON	FS	TECHNOLOGY
3142	IRV	NB	ALTON	FS	MUIRLANDS
3143	IRV	NB	ALTON	FS	HUGHES
3144	IRV	NB	ALTON	FS	MORGAN
3145	IRV	NB	ALTON	FS	TOLEDO
3146	IRV	NB	ALTON	FS	FAIRBANKS
3147	IRV	NB	ALTON	FS	FOSTER
3148	IRV	SB	ALTON	FS	FOSTER
3149	IRV	SB	ALTON	FS	TOLEDO
3150	IRV	SB	ALTON	FS	MORGAN
3151	IRV	SB	ALTON	FS	HUGHES
3152	IRV	SB	ALTON	FS	JERONIMO
3153	IRV	WB	ALTON	FS	BARRANCA
3154	IRV	WB	ALTON	FS	TECHNOLOGY
3155	IRV	WB	ALTON	FS	MAUCHLY
3156	IRV	WB	ALTON	FS	ADA
3157	IRV	WB	ALTON	OPP	GATEWAY
3158	IRV	WB	ALTON	FS	IRVINE CENTER
3159	IRV	WB	ALTON	FS	PACIFICA
3160	IRV	WB	ALTON	FS	BANTING
3161	IRV	WB	ALTON	FS	ENT 15955 CANNON
3162	IRV	WB	ALTON	FS	LAGUNA CANYON
3163	IRV	WB	ALTON	FS	PERMANENTE
3164	IRV	WB	ALTON	FS	SAND CANYON
3165	IRV	WB	ALTON	FS	VALLEY OAK
3166	IRV	WB	ALTON	FS	ROYAL OAK
3167	IRV	WB	ALTON	FS	JEFFREY
3168	IRV	WB	ALTON	FS	EAST YALE LOOP
3169	IRV	WB	ALTON	FS	ENT 5051 CEDAR CREEK
3170	IRV	WB	ALTON	FS	CREEK
3171	IRV	WB	ALTON	NS	LAKE
3172	IRV	WB	ALTON	FS	MEADOWBROOK
3173	IRV	WB	ALTON	FS	WEST YALE LOOP
3174	IRV	WB	ALTON	OPP	SAN MARINO

Bus Stop Maintenance

RFP 1-3408

All Stop Locations

Exhibit A

Attachment 2

OCTA_ID	CITY	DIR	STREET_OF_TRAVEL	LOC	CROSS_STREET
3175	IRV	WB	ALTON	FS	PASEO WESTPARK
3176	IRV	WB	ALTON	FS	HARVARD
3177	IRV	WB	ALTON	NS	MURPHY
3178	IRV	WB	ALTON	FS	JAMBOREE
3179	IRV	WB	ALTON	NS	MILLIKEN
3180	IRV	WB	ALTON	FS	ENT 2481 ALLIED VAN LINES
3181	IRV	WB	ALTON	FS	VON KARMAN
3182	IRV	WB	ALTON	FS	ARMSTRONG
3183	IRV	WB	ALTON	NS	ARMSTRONG
3184	IRV	WB	ALTON	NS	ASTON
3185	IRV	NB	BAKE	VFS	ROCKFIELD
3186	IRV	NB	BAKE	VFS	MUIRLANDS
3187	IRV	SB	BAKE	OPP	CAPE
3188	IRV	SB	BAKE	FS	IRVINE
3189	IRV	SB	BAKE	FS	CROMWELL
3190	IRV	SB	BAKE	FS	TOLEDO
3191	IRV	SB	BAKE	FS	JERONIMO
3192	IRV	SB	BAKE	VNS	MUIRLANDS
3193	IRV	SB	BAKE	FS	MUIRLANDS
3194	IRV	EB	BARRANCA	FS	RED HILL
3195	IRV	EB	BARRANCA	FS	ASTON
3196	IRV	EB	BARRANCA	FS	ARMSTRONG
3197	IRV	EB	BARRANCA	FS	VON KARMAN
3198	IRV	EB	BARRANCA	NS	JAMBOREE
3199	IRV	EB	BARRANCA	FS	CORPORATE PARK
3200	IRV	EB	BARRANCA	FS	HARVARD
3201	IRV	EB	BARRANCA	FS	PASEO WESTPARK
3202	IRV	EB	BARRANCA	FS	CULVER
3203	IRV	EB	BARRANCA	FS	LAKE
3204	IRV	EB	BARRANCA	@	4600 WOODBRIDGE VILLAGE
3205	IRV	EB	BARRANCA	FS	CREEK
3206	IRV	EB	BARRANCA	FS	LYON
3207	IRV	EB	BARRANCA	FS	TECHNOLOGY
3208	IRV	EB	BARRANCA	FS	ENT 15330 WONDERWARE
3209	IRV	EB	BARRANCA	FS	ADA
3210	IRV	EB	BARRANCA	FS	ALTON
3211	IRV	WB	BARRANCA	FS	ALTON
3212	IRV	WB	BARRANCA	VNS	ADA
3213	IRV	WB	BARRANCA	FS	ADA
3214	IRV	WB	BARRANCA	FS	ENT 15345 WESTERN DIGITAL
3215	IRV	WB	BARRANCA	FS	TECHNOLOGY
3216	IRV	WB	BARRANCA	FS	EAST YALE LOOP
3217	IRV	WB	BARRANCA	OPP	LYON
3218	IRV	WB	BARRANCA	NS	CREEK
3219	IRV	WB	BARRANCA	OPP	4600 WOODBRIDGE VILLAGE
3220	IRV	WB	BARRANCA	VFS	CULVER

Bus Stop Maintenance

All Stop Locations

RFP 1-3408

Exhibit A

Attachment 2

OCTA_ID	CITY	DIR	STREET_OF_TRAVEL	LOC	CROSS_STREET
3221	IRV	WB	BARRANCA	FS	PASEO WESTPARK
3222	IRV	WB	BARRANCA	FS	HARVARD
3223	IRV	WB	BARRANCA	VNS	JAMBOREE
3224	TUST	WB	BARRANCA	OPP	ARMSTRONG
3225	IRV	NB	BERKELEY	NS	CORNELL
3226	IRV	NB	BRIDGE	FS	CAMPUS
3227	IRV	EB	BRYAN	FS	JAMBOREE
3228	IRV	EB	BRYAN	VFS	MARKET
3229	IRV	EB	BRYAN	FS	EL CAMINO REAL NORTH
3230	IRV	EB	BRYAN	FS	CULVER
3231	IRV	EB	BRYAN	FS	GURLEY
3232	IRV	EB	BRYAN	NS	WESTWOOD
3233	IRV	WB	BRYAN	FS	YALE
3234	IRV	WB	BRYAN	FS	WESTWOOD
3235	IRV	WB	BRYAN	NS	COLONIAL
3236	IRV	WB	BRYAN	FS	CULVER
3237	IRV	WB	BRYAN	OPP	EL CAMINO REAL NORTH
3238	IRV	WB	BRYAN	FS	MARKET
3239	IRV	NB	CALIFORNIA	FS	WEST PELTASON
3240	IRV	NB	CALIFORNIA	FS	CAMPUS
3241	IRV	NB	CALIFORNIA	NS	HARVARD
3242	IRV	SB	CALIFORNIA	OPP	BRIDGE
3243	IRV	SB	CALIFORNIA	FS	HARVARD
3244	IRV	EB	CAMPUS	FS	JAMBOREE
3245	IRV	EB	CAMPUS	FS	UNIVERSITY
3246	IRV	EB	CAMPUS	OPP	UNIVERSITY CENTER
3247	IRV	EB	CAMPUS	FS	EAST PELTASON
3248	IRV	EB	CAMPUS	OPP	CORNELL
3249	IRV	EB	CAMPUS	FS	CALIFORNIA
3250	IRV	WB	CAMPUS	FS	CULVER
3251	IRV	WB	CAMPUS	FS	CALIFORNIA
3252	IRV	WB	CAMPUS	FS	CORNELL
3253	IRV	WB	CAMPUS	NS	BERKELEY
3254	IRV	WB	CAMPUS	@	UNIVERSITY CENTER
3255	IRV	WB	CAMPUS	VFS	UNIVERSITY
3256	IRV	WB	CAMPUS	FS	CARLSON
3257	IRV	WB	CAMPUS	FS	JAMBOREE
3258	IRV	WB	CAMPUS	FS	TELLER
3259	IRV	WB	CAMPUS	FS	BARDEEN
3260	IRV	WB	CAMPUS	FS	VON KARMAN
3261	IRV	WB	CAMPUS	NS	MARTIN
3262	IRV	NB	CULVER	FS	CAMPUS
3263	IRV	NB	CULVER	OPP	HARVARD
3264	IRV	NB	CULVER	FS	UNIVERSITY
3265	IRV	NB	CULVER	FS	SANDBURG
3266	IRV	NB	CULVER	NS	MICHELSON

Bus Stop Maintenance

RFP 1-3408

All Stop Locations

Exhibit A

Attachment 2

OCTA_ID	CITY	DIR	STREET_OF_TRAVEL	LOC	CROSS_STREET
3267	IRV	NB	CULVER	OPP	FERRIS
3268	IRV	NB	CULVER	OPP	SAN LEANDRO
3269	IRV	NB	CULVER	VFS	MAIN
3270	IRV	NB	CULVER	FS	ALTON
3271	IRV	NB	CULVER	FS	BARRANCA
3272	IRV	NB	CULVER	FS	WARNER
3273	IRV	NB	CULVER	FS	IRVINE CENTER
3274	IRV	NB	CULVER	FS	DEERFIELD
3275	IRV	NB	CULVER	@	LOMA
3276	IRV	NB	CULVER	FS	WALNUT
3277	IRV	NB	CULVER	OPP	SCOTTSDALE
3278	IRV	NB	CULVER	FS	ESCUDERO
3279	IRV	NB	CULVER	FS	FARWELL
3280	IRV	NB	CULVER	FS	BRYAN
3281	IRV	NB	CULVER	FS	FLORENCE TERRACIMA
3282	IRV	NB	CULVER	FS	IRVINE
3283	IRV	SB	CULVER	FS	IRVINE
3284	IRV	SB	CULVER	OPP	FLORENCE TERRACIMA
3285	IRV	SB	CULVER	FS	BRYAN
3286	IRV	SB	CULVER	OPP	FARWELL
3287	IRV	SB	CULVER	OPP	ESCUDERO
3288	IRV	SB	CULVER	FS	SCOTTSDALE
3289	IRV	SB	CULVER	FS	WALNUT
3290	IRV	SB	CULVER	FS	DEERFIELD
3291	IRV	SB	CULVER	VFS	IRVINE CENTER
3292	IRV	SB	CULVER	FS	WARNER
3293	IRV	SB	CULVER	FS	BARRANCA
3294	IRV	SB	CULVER	FS	ALTON
3295	IRV	SB	CULVER	VFS	MAIN
3296	IRV	SB	CULVER	FS	SAN LEANDRO
3297	IRV	SB	CULVER	NS	FERRIS
3298	IRV	SB	CULVER	FS	MICHELSON
3299	IRV	SB	CULVER	FS	ETHEL COPLEN
3300	IRV	SB	CULVER	FS	UNIVERSITY
3301	IRV	SB	CULVER	FS	HARVARD
3302	IRV	NB	EAST YALE LOOP	FS	BARRANCA
3303	IRV	NB	EAST YALE LOOP	FS	RIVERRUN
3304	IRV	NB	EAST YALE LOOP	NS	ALDERWOOD
3305	IRV	NB	EAST YALE LOOP	FS	WOODSPRING
3306	IRV	SB	EAST YALE LOOP	OPP	YALE
3307	IRV	SB	EAST YALE LOOP	FS	WOODSPRING
3308	IRV	SB	EAST YALE LOOP	OPP	ALDERWOOD
3309	IRV	SB	EAST YALE LOOP	FS	EASTSHORE
3310	IRV	NB	EASTWOOD	NS	COLUMBUS
3311	IRV	NB	EASTWOOD	NS	BRYAN
3312	IRV	NB	EASTWOOD	FS	MONTECITO

Bus Stop Maintenance

RFP 1-3408

All Stop Locations

Exhibit A

Attachment 2

OCTA_ID	CITY	DIR	STREET_OF_TRAVEL	LOC	CROSS_STREET
3313	IRV	SB	EASTWOOD	FS	MONTECITO
3314	IRV	SB	EASTWOOD	FS	BRYAN
3315	IRV	SB	EASTWOOD	FS	COLUMBUS
3316	IRV	NB	FAIRBANKS	FS	ALTON
3317	IRV	SB	FAIRBANKS	FS	IRVINE
3318	IRV	NB	FITCH	FS	MITCHELL
3319	IRV	NB	FITCH	NS	COWAN
3320	IRV	SB	FITCH	FS	COWAN
3321	IRV	SB	FITCH	NS	MITCHELL
3322	IRV	SB	FORTUNE	FS	GATEWAY
3323	IRV	SB	FORTUNE	NS	PACIFICA
3324	IRV	SB	FORTUNE	FS	PACIFICA
3325	IRV	SB	GATEWAY	FS	ALTON
3326	IRV	NB	GOODYEAR	VFS	JERONIMO
3327	IRV	NB	GOODYEAR	OPP	FLEMING
3328	IRV	NB	GOODYEAR	OPP	MORGAN
3329	IRV	SB	GOODYEAR	FS	TOLEDO
3330	IRV	SB	GOODYEAR	FS	FLEMING
3331	IRV	WB	HAMMOND	OPP	PARKER
3332	IRV	WB	HAMMOND	NS	MUSICK
3333	IRV	SB	HARVARD	FS	MICHELSON
3334	IRV	SB	HARVARD	NS	STANFORD
3335	IRV	SB	HARVARD	FS	BRIDGE
3336	IRV	EB	HARVARD	NS	BERKELEY
3337	IRV	EB	HARVARD	FS	COLUMBIA
3338	IRV	WB	HARVARD	OPP	CALIFORNIA
3339	IRV	WB	HARVARD	OPP	BERKELEY
3340	IRV	WB	HARVARD	FS	CULVER
3341	IRV	WB	HARVARD	OPP	COLUMBIA
3342	IRV	NB	HARVARD	NS	BRIDGE
3343	IRV	NB	HARVARD	OPP	STANFORD
3344	IRV	EB	HOLLAND	FS	STERLING
3345	IRV	WB	HOLLAND	OPP	THOMAS
3346	IRV	WB	HOLLAND	OPP	STERLING
3347	IRV	WB	INNOVATION	VFS	CALIFORNIA
3348	IRV	EB	IRVINE	FS	JAMBOREE
3349	IRV	EB	IRVINE	FS	CULVER
3350	IRV	EB	IRVINE	OPP	PALO LADO
3351	IRV	EB	IRVINE	NS	YALE
3352	IRV	EB	IRVINE	FS	YALE
3353	IRV	EB	IRVINE	FS	PUEBLO NORTE
3354	IRV	EB	IRVINE	FS	FAIRBANKS
3355	IRV	EB	IRVINE	FS	PARKER
3356	IRV	WB	IRVINE	FS	BAKE
3357	IRV	WB	IRVINE	FS	PARKER
3358	IRV	WB	IRVINE	FS	MUSICK

Bus Stop Maintenance

RFP 1-3408

All Stop Locations

Exhibit A

Attachment 2

OCTA_ID	CITY	DIR	STREET_OF_TRAVEL	LOC	CROSS_STREET
3359	IRV	WB	IRVINE	OPP	PUEBLO NORTE
3360	IRV	WB	IRVINE	FS	YALE
3361	IRV	WB	IRVINE	FS	PALO LADO
3362	IRV	WB	IRVINE	FS	CULVER
3363	IRV	EB	IRVINE CENTER	FS	HARVARD
3364	IRV	EB	IRVINE CENTER	FS	HEARTHSTONE
3365	IRV	EB	IRVINE CENTER	FS	CULVER
3366	IRV	EB	IRVINE CENTER	OPP	DEERWOOD
3367	IRV	EB	IRVINE CENTER	FS	YALE
3368	IRV	EB	IRVINE CENTER	OPP	FONTAINE
3369	IRV	EB	IRVINE CENTER	FS	JEFFREY
3370	IRV	EB	IRVINE CENTER	FS	ORANGETREE
3371	IRV	EB	IRVINE CENTER	FS	VALLEY OAK
3372	IRV	EB	IRVINE CENTER	FS	SAND CANYON
3373	IRV	EB	IRVINE CENTER	FS	ODYSSEY
3374	IRV	EB	IRVINE CENTER	FS	LAGUNA CANYON
3375	IRV	EB	IRVINE CENTER	FS	DISCOVERY
3376	IRV	SB	IRVINE CENTER	FS	BARRANCA
3377	IRV	SB	IRVINE CENTER	FS	ALTON
3378	IRV	SB	IRVINE CENTER	FS	SPECTRUM
3379	IRV	SB	IRVINE CENTER	OPP	RESEARCH
3380	IRV	SB	IRVINE CENTER	OPP	HUBBLE
3381	IRV	SB	IRVINE CENTER	FS	BAKE
3382	IRV	SB	IRVINE CENTER	FS	TESLA
3383	IRV	SB	IRVINE CENTER	FS	SCIENTIFIC
3384	IRV	SB	IRVINE CENTER	OPP	VALENCIA
3385	IRV	NB	IRVINE CENTER	FS	LAKE FOREST
3386	IRV	NB	IRVINE CENTER	FS	VALENCIA
3387	IRV	NB	IRVINE CENTER	FS	SCIENTIFIC
3388	IRV	NB	IRVINE CENTER	FS	TESLA
3389	IRV	NB	IRVINE CENTER	FS	BAKE
3390	IRV	NB	IRVINE CENTER	FS	HUBBLE
3391	IRV	NB	IRVINE CENTER	NS	RESEARCH
3392	IRV	NB	IRVINE CENTER	FS	PACIFICA
3393	IRV	NB	IRVINE CENTER	FS	ALTON
3394	IRV	NB	IRVINE CENTER	FS	GATEWAY
3395	IRV	WB	IRVINE CENTER	FS	CHARTER
3396	IRV	WB	IRVINE CENTER	FS	DISCOVERY
3397	IRV	WB	IRVINE CENTER	FS	LAGUNA CANYON
3398	IRV	WB	IRVINE CENTER	OPP	ODYSSEY
3399	IRV	WB	IRVINE CENTER	FS	SAND CANYON
3400	IRV	WB	IRVINE CENTER	FS	VALLEY OAK
3401	IRV	WB	IRVINE CENTER	FS	GOLF CLUB
3402	IRV	WB	IRVINE CENTER	FS	JEFFREY
3403	IRV	WB	IRVINE CENTER	FS	LORRAINE
3404	IRV	WB	IRVINE CENTER	FS	FONTAINE

Bus Stop Maintenance

All Stop Locations

RFP 1-3408

Exhibit A

Attachment 2

OCTA_ID	CITY	DIR	STREET_OF_TRAVEL	LOC	CROSS_STREET
3405	IRV	WB	IRVINE CENTER	FS	YALE
3406	IRV	WB	IRVINE CENTER	FS	DEERWOOD
3407	IRV	WB	IRVINE CENTER	FS	BEAR PAW
3408	IRV	WB	IRVINE CENTER	FS	CULVER
3409	IRV	WB	IRVINE CENTER	FS	HEARTHSTONE
3410	TUST	WB	IRVINE CENTER	FS	HARVARD
3411	IRV	NB	JAMBOREE	FS	FAIRCHILD
3412	IRV	NB	JAMBOREE	OPP	BIRCH
3413	IRV	NB	JAMBOREE	FS	CAMPUS
3414	IRV	NB	JAMBOREE	OPP	DUPONT
3415	IRV	NB	JAMBOREE	VNS	MICHELSON
3416	IRV	NB	JAMBOREE	VFS	MAIN
3417	IRV	NB	JAMBOREE	FS	KELVIN
3418	IRV	NB	JAMBOREE	FS	MCGAW
3419	IRV	NB	JAMBOREE	FS	ALTON
3420	IRV	NB	JAMBOREE	VNS	BARRANCA
3421	IRV	NB	JAMBOREE	FS	EL CAMINO REAL
3422	IRV	NB	JAMBOREE	FS	BRYAN
3423	IRV	NB	JAMBOREE	OPP	TUSTIN RANCH PLAZA
3424	IRV	SB	JAMBOREE	FS	BARRANCA
3425	IRV	SB	JAMBOREE	FS	BECKMAN
3426	IRV	SB	JAMBOREE	FS	RICHTER
3427	IRV	SB	JAMBOREE	FS	ALTON
3428	IRV	SB	JAMBOREE	FS	MCGAW
3429	IRV	SB	JAMBOREE	FS	KELVIN
3430	IRV	SB	JAMBOREE	NS	MAIN
3431	IRV	SB	JAMBOREE	FS	MICHELSON
3432	IRV	SB	JAMBOREE	FS	DUPONT
3433	IRV	NB	JEFFREY	NS	QUAILCREEK
3434	IRV	NB	JEFFREY	OPP	TRIOMPHE
3435	IRV	NB	JEFFREY	OPP	SMOKETREE
3436	IRV	NB	JEFFREY	OPP	THE MEADOWS
3437	IRV	SB	JEFFREY	FS	THE MEADOWS
3438	IRV	SB	JEFFREY	FS	SMOKETREE
3439	IRV	SB	JEFFREY	NS	TRIOMPHE
3440	IRV	SB	JEFFREY	OPP	QUAILCREEK
3441	IRV	EB	JERONIMO	VFS	ALTON
3442	IRV	EB	JERONIMO	FS	ENT 9600 LIEBERT
3443	IRV	EB	JERONIMO	OPP	GOODYEAR
3444	IRV	WB	JERONIMO	VFS	BAKE
3445	IRV	WB	JERONIMO	FS	GOODYEAR
3446	IRV	WB	JERONIMO	OPP	ENT 9600 LIEBERT
3447	IRV	WB	JERONIMO	VNS	ALTON
3448	CYP	SB	VALLEY VIEW	FS	CORPORATE
3449	IRV	SB	LAKE	VFS	BARRANCA
3450	IRV	SB	LAKE	FS	GREG COPS

Bus Stop Maintenance

All Stop Locations

RFP 1-3408

Exhibit A

Attachment 2

OCTA_ID	CITY	DIR	STREET_OF_TRAVEL	LOC	CROSS_STREET
3451	IRV	NB	LAKE	VNS	BARRANCA
3452	IRV	WB	LAKE FOREST	FS	IRVINE CENTER
3453	IRV	EB	MACARTHUR	FS	FITCH
3454	IRV	EB	MACARTHUR	FS	RED HILL
3455	IRV	SB	MACARTHUR	FS	SKY PARK EAST
3456	IRV	SB	MACARTHUR	NS	MAIN
3457	IRV	SB	MACARTHUR	OPP	MICHELSON
3458	IRV	WB	MACARTHUR	OPP	FITCH
3459	IRV	EB	MAIN	FS	MCDURMOTT WEST
3460	IRV	EB	MAIN	FS	RED HILL
3461	IRV	EB	MAIN	FS	EXECUTIVE PARK
3462	IRV	EB	MAIN	NS	MACARTHUR
3463	IRV	EB	MAIN	OPP	GILLETTE
3464	IRV	EB	MAIN	FS	VON KARMAN
3465	IRV	EB	MAIN	FS	CARTWRIGHT
3466	IRV	EB	MAIN	OPP	SIGLO
3467	IRV	EB	MAIN	FS	UNION
3468	IRV	EB	MAIN	FS	VENETO
3469	IRV	EB	MAIN	FS	HARVARD
3470	IRV	EB	MAIN	FS	SAN MATEO
3471	IRV	EB	MAIN	NS	PASEO WESTPARK
3472	IRV	EB	MAIN	OPP	SAN PAULO
3473	IRV	WB	MAIN	VFS	CULVER
3474	IRV	WB	MAIN	FS	PASEO WESTPARK
3475	IRV	WB	MAIN	FS	SAN MATEO
3476	IRV	WB	MAIN	NS	HARVARD
3477	IRV	WB	MAIN	FS	VENETO
3478	IRV	WB	MAIN	OPP	UNION
3479	IRV	WB	MAIN	FS	JAMBOREE
3480	IRV	WB	MAIN	FS	CARTWRIGHT
3481	IRV	WB	MAIN	FS	VON KARMAN
3482	IRV	WB	MAIN	FS	GILLETTE
3483	IRV	WB	MAIN	OPP	MERCANTILE
3484	IRV	WB	MAIN	FS	MACARTHUR
3485	IRV	WB	MAIN	FS	RED HILL
3486	IRV	WB	MAIN	OPP	MCDURMOTT WEST
3487	IRV	NB	MARCONI	OPP	HOLLAND
3488	IRV	SB	MARCONI	FS	HOLLAND
3489	IRV	EB	MCGAW	FS	RED HILL
3490	IRV	EB	MCGAW	FS	ARMSTRONG
3491	IRV	EB	MCGAW	FS	VON KARMAN
3492	IRV	EB	MCGAW	FS	DERIAN
3493	IRV	EB	MCGAW	NS	JAMBOREE
3494	IRV	WB	MCGAW	FS	JAMBOREE
3495	IRV	WB	MCGAW	OPP	DERIAN
3496	IRV	WB	MCGAW	FS	VON KARMAN

Bus Stop Maintenance

RFP 1-3408

All Stop Locations

Exhibit A

Attachment 2

OCTA_ID	CITY	DIR	STREET_OF_TRAVEL	LOC	CROSS_STREET
3497	IRV	WB	MCGAW	FS	ARMSTRONG
3498	IRV	WB	MCGAW	FS	GILLETTE
3499	IRV	EB	MICHELSON	NS	DUPONT
3500	IRV	EB	MICHELSON	FS	VON KARMAN
3501	IRV	EB	MICHELSON	OPP	OBSIDIAN
3502	IRV	EB	MICHELSON	NS	TELLER
3503	IRV	EB	MICHELSON	NS	JAMBOREE
3504	IRV	EB	MICHELSON	FS	CARLSON
3505	IRV	EB	MICHELSON	NS	RIPARIAN
3506	IRV	EB	MICHELSON	OPP	PARKWAY
3507	IRV	EB	MICHELSON	OPP	PARKSIDE
3508	IRV	EB	MICHELSON	OPP	MANN
3509	IRV	EB	MICHELSON	FS	SANDBURG
3510	IRV	EB	MICHELSON	OPP	ELM TREE
3511	IRV	EB	MICHELSON	FS	REDWOOD TREE
3512	IRV	EB	MICHELSON	FS	SEQUOIA TREE
3513	IRV	EB	MICHELSON	FS	YALE
3514	IRV	EB	MICHELSON	FS	ROYCE
3515	IRV	EB	MICHELSON	FS	ROSA DREW
3516	IRV	EB	MICHELSON	OPP	JORDAN
3517	IRV	WB	MICHELSON	FS	JORDAN EAST
3518	IRV	WB	MICHELSON	FS	JORDAN
3519	IRV	WB	MICHELSON	FS	YALE
3520	IRV	WB	MICHELSON	FS	BANYON TREE
3521	IRV	WB	MICHELSON	FS	PINYON TREE
3522	IRV	WB	MICHELSON	FS	ELM TREE
3523	IRV	WB	MICHELSON	FS	SETON
3524	IRV	WB	MICHELSON	NS	BASCOM
3525	IRV	WB	MICHELSON	FS	CULVER
3526	IRV	WB	MICHELSON	VFS	PARKSIDE
3527	IRV	WB	MICHELSON	FS	PARKWAY
3528	IRV	WB	MICHELSON	FS	HARVARD
3529	IRV	WB	MICHELSON	FS	RIPARIAN
3530	IRV	WB	MICHELSON	OPP	CARLSON
3531	IRV	WB	MICHELSON	OPP	TELLER
3532	IRV	WB	MICHELSON	NS	VON KARMAN
3533	IRV	WB	MICHELSON	FS	VON KARMAN
3534	IRV	WB	MICHELSON	FS	DUPONT
3535	IRV	EB	MUIRLANDS	FS	THOMAS
3536	IRV	EB	MUIRLANDS	FS	WRIGLEY
3537	IRV	EB	MUIRLANDS	FS	BAKE
3538	IRV	WB	MUIRLANDS	OPP	WRIGLEY
3539	IRV	WB	NORTHWOOD	OPP	GOLD RUSH
3540	IRV	WB	NORTHWOOD	FS	YALE
3541	IRV	WB	NORTHWOOD	FS	MONITOR
3542	IRV	EB	NORTHWOOD	FS	YALE

Bus Stop Maintenance

RFP 1-3408

All Stop Locations

Exhibit A

Attachment 2

OCTA_ID	CITY	DIR	STREET_OF_TRAVEL	LOC	CROSS_STREET
3543	IRV	NB	PARKER	FS	TOLEDO
3544	IRV	NB	PARKER	FS	CROMWELL
3545	IRV	NB	PARKER	FS	IRVINE
3546	IRV	SB	PARKER	FS	IRVINE
3547	IRV	SB	PARKER	OPP	CROMWELL
3548	IRV	NB	RED HILL	FS	MAIN
3549	IRV	NB	RED HILL	OPP	MITCHELL SOUTH
3550	IRV	NB	RED HILL	FS	SKY PARK NORTH
3551	IRV	NB	RED HILL	NS	MACARTHUR
3552	IRV	NB	RED HILL	FS	REYNOLDS
3553	IRV	NB	RED HILL	FS	MCGAW
3554	IRV	NB	RED HILL	FS	ALTON
3555	IRV	NB	RED HILL	NS	DEERE
3556	IRV	SB	RED HILL	FS	ALTON
3557	IRV	SB	RED HILL	FS	MCGAW
3558	IRV	SB	RED HILL	NS	REYNOLDS
3559	IRV	SB	RED HILL	FS	MACARTHUR
3560	IRV	SB	RED HILL	FS	MITCHELL NORTH
3561	IRV	SB	RED HILL	@	TECHNOLOGY MARKETING
3562	IRV	SB	RED HILL	FS	MITCHELL SOUTH
3563	IRV	SB	RED HILL	FS	MAIN
3564	IRV	EB	ROCKFIELD	VFS	BAKE
3565	IRV	EB	ROCKFIELD	VFS	OLDFIELD
3566	IRV	EB	ROCKFIELD	FS	REVSON
3567	IRV	WB	ROCKFIELD	OPP	REVSON
3568	IRV	WB	ROCKFIELD	FS	OLDFIELD
3569	IRV	NB	SAN JOAQUIN	FS	MONTANAS SUD
3570	IRV	NB	SAN JOAQUIN	FS	NUEVO
3571	IRV	NB	SAN JOAQUIN	NS	ESPLANADE
3572	IRV	NB	SAN JOAQUIN	NS	ETHEL COPLEN
3573	IRV	SB	SAN JOAQUIN	NS	LAS BRISAS
3574	IRV	SB	SAN JOAQUIN	FS	ARBOLES
3575	IRV	SB	SAN JOAQUIN	NS	MONTANAS ESTE
3576	IRV	NB	SAND CANYON	FS	BARRANCA
3577	IRV	NB	SAND CANYON	FS	WATER WORKS
3578	IRV	NB	SAND CANYON	FS	IRVINE CENTER
3579	IRV	NB	SAND CANYON	FS	BURT
3580	IRV	NB	SAND CANYON	FS	MARINE
3581	IRV	NB	SAND CANYON	NS	ENT 14600 IRVINE
3582	IRV	SB	SAND CANYON	OPP	ENT 14600 IRVINE
3583	IRV	SB	SAND CANYON	NS	BURT
3584	IRV	SB	SAND CANYON	FS	OAK CANYON
3585	IRV	SB	SAND CANYON	FS	IRVINE CENTER
3586	IRV	SB	SAND CANYON	FS	WATER WORKS
3587	IRV	EB	ETHEL COPLEN	NS	PERGOLA
3588	IRV	WB	ETHEL COPLEN	FS	CULVER

Bus Stop Maintenance

RFP 1-3408

All Stop Locations

Exhibit A

Attachment 2

OCTA_ID	CITY	DIR	STREET_OF_TRAVEL	LOC	CROSS_STREET
3589	IRV	WB	ETHEL COPLEN	OPP	SAN JOAQUIN
3590	IRV	EB	SOUTHWOOD	FS	YALE
3591	IRV	EB	SOUTHWOOD	FS	COLT
3592	IRV	EB	SOUTHWOOD	OPP	HAMPTON
3593	IRV	WB	SOUTHWOOD	NS	COLT
3594	IRV	EB	SPECTRUM	NS	FORTUNE
3595	IRV	WB	TECHNOLOGY	FS	ALTON
3596	IRV	NB	TECHNOLOGY	FS	ENT 16 TECHNOLOGY
3597	IRV	NB	TECHNOLOGY	FS	ENT 18 TECHNOLOGY
3598	IRV	NB	TECHNOLOGY	FS	ALTON
3599	IRV	SB	TECHNOLOGY	FS	BARRANCA
3600	IRV	SB	TECHNOLOGY	FS	ALTON
3601	IRV	SB	TECHNOLOGY	FS	ENT 25 TECHNOLOGY
3602	IRV	SB	TECHNOLOGY	FS	ENT 19 TECHNOLOGY
3603	IRV	SB	TECHNOLOGY	FS	ONE TECHNOLOGY PARK
3604	IRV	SB	THOMAS	FS	HOLLAND
3605	IRV	EB	TOLEDO	FS	ALTON
3606	IRV	EB	TOLEDO	OPP	PARKER
3607	IRV	EB	TOLEDO	FS	GOODYEAR
3608	IRV	WB	TOLEDO	OPP	GOODYEAR
3609	IRV	WB	TOLEDO	FS	PARKER
3610	IRV	WB	UNIVERSITY	FS	CULVER
3611	IRV	WB	UNIVERSITY	NS	ENT 3773 MARIPOSA VILLA
3612	IRV	WB	UNIVERSITY	OPP	MESA
3613	IRV	NB	VON KARMAN	FS	CAMPUS
3614	IRV	NB	VON KARMAN	OPP	MARTIN
3615	IRV	NB	VON KARMAN	VFS	DUPONT
3616	IRV	NB	VON KARMAN	VNS	MICHELSON
3617	IRV	NB	VON KARMAN	NS	QUARTZ
3618	IRV	NB	VON KARMAN	FS	MORSE
3619	IRV	NB	VON KARMAN	FS	MAIN
3620	IRV	NB	VON KARMAN	NS	ENT 17510 VON KARMAN
3621	IRV	NB	VON KARMAN	NS	ENT 17622 PACIFIC CREST
3622	IRV	NB	VON KARMAN	FS	MCGAW
3623	IRV	NB	VON KARMAN	FS	ALTON
3624	IRV	SB	VON KARMAN	FS	BARRANCA
3625	IRV	SB	VON KARMAN	FS	ALTON
3626	IRV	SB	VON KARMAN	FS	MCGAW
3627	IRV	SB	VON KARMAN	NS	ENT 17451 DEFT
3628	IRV	SB	VON KARMAN	NS	ENT 17875 WASHINGTON
3629	IRV	SB	VON KARMAN	VFS	MAIN
3630	IRV	SB	VON KARMAN	FS	QUARTZ
3631	IRV	SB	VON KARMAN	FS	MICHELSON
3632	IRV	SB	VON KARMAN	FS	ENT 18651 FEDERAL EXPRESS
3633	IRV	SB	VON KARMAN	FS	DUPONT
3634	IRV	SB	VON KARMAN	FS	MARTIN

Bus Stop Maintenance

All Stop Locations

RFP 1-3408

Exhibit A

Attachment 2

OCTA_ID	CITY	DIR	STREET_OF_TRAVEL	LOC	CROSS_STREET
3635	IRV	EB	WALNUT	FS	MYFORD
3636	IRV	EB	WALNUT	NS	HARVARD
3637	IRV	EB	WALNUT	FS	THE MALL
3638	IRV	EB	WALNUT	FS	LIME
3639	IRV	EB	WALNUT	FS	CULVER
3640	IRV	EB	WALNUT	OPP	BUTTERFLY
3641	IRV	EB	WALNUT	FS	RAVENWOOD
3642	IRV	EB	WALNUT	@	COUNTRYWOOD
3643	IRV	EB	WALNUT	FS	YALE
3644	IRV	EB	WALNUT	FS	RYEWOOD
3645	IRV	EB	WALNUT	NS	KAZAN
3646	IRV	EB	WALNUT	OPP	AUSTIN
3647	IRV	EB	WALNUT	FS	WISTERIA
3648	IRV	WB	WALNUT	FS	WISTERIA
3649	IRV	WB	WALNUT	FS	AUSTIN
3650	IRV	WB	WALNUT	OPP	KAZAN
3651	IRV	WB	WALNUT	FS	HARTFORD
3652	IRV	WB	WALNUT	FS	YALE
3653	IRV	WB	WALNUT	OPP	COUNTRYWOOD
3654	IRV	WB	WALNUT	OPP	RAVENWOOD
3655	IRV	WB	WALNUT	FS	BUTTERFLY
3656	IRV	WB	WALNUT	VFS	CULVER
3657	IRV	WB	WALNUT	OPP	LIME
3658	IRV	WB	WALNUT	FS	THE MALL
3659	IRV	WB	WALNUT	FS	HARVARD
3660	IRV	EB	WARNER	FS	CULVER
3661	IRV	WB	WARNER	FS	WEST YALE LOOP
3662	IRV	WB	WARNER	OPP	ENT 2810 IRVINE INN
3663	IRV	EB	WEST PELTASON	OPP	UCI CRAWFORD HALL
3664	IRV	EB	WEST PELTASON	FS	CALIFORNIA
3665	IRV	EB	WEST PELTASON	FS	MESA
3666	IRV	WB	WEST PELTASON	NS	MESA
3667	IRV	WB	WEST PELTASON	@	UCI CRAWFORD HALL
3668	IRV	WB	WEST YALE LOOP	FS	YALE
3669	IRV	WB	WEST YALE LOOP	OPP	LEMONGRASS
3670	IRV	WB	WEST YALE LOOP	FS	WOODHOLLOW
3671	IRV	SB	WEST YALE LOOP	FS	STONE CREEK NORTH
3672	IRV	SB	WEST YALE LOOP	FS	BARRANCA
3673	IRV	NB	WEST YALE LOOP	OPP	BURWOOD
3674	IRV	NB	WEST YALE LOOP	FS	STONE CREEK NORTH
3675	IRV	EB	WEST YALE LOOP	OPP	WOODHOLLOW
3676	IRV	EB	WEST YALE LOOP	FS	LEMONGRASS
3677	IRV	SB	WESTWOOD	NS	MAYFLOWER
3678	IRV	SB	WESTWOOD	FS	BRYAN
3679	IRV	SB	WESTWOOD	FS	ADAMS
3680	IRV	SB	YALE	FS	SOUTHWOOD

Bus Stop Maintenance
All Stop Locations

RFP 1-3408
Exhibit A
Attachment 2

OCTA_ID	CITY	DIR	STREET_OF_TRAVEL	LOC	CROSS_STREET
3681	IRV	NB	YALE	NS	SACRAMENTO
3682	IRV	NB	YALE	NS	ROOSEVELT
3683	IRV	NB	YALE	FS	TRABUCO
3684	IRV	NB	YALE	FS	EAST YALE LOOP
3685	IRV	NB	YALE	FS	SOUTHWOOD
3686	IRV	NB	YALE	FS	BRYAN
3687	IRV	NB	YALE	FS	MONTICELLO
3688	IRV	NB	YALE	FS	NORTHWOOD
3689	IRV	SB	YALE	FS	IRVINE
3690	IRV	SB	YALE	NS	TRABUCO
3691	IRV	SB	YALE	NS	ROOSEVELT
3692	IRV	SB	YALE	FS	NORTHWOOD
3693	IRV	SB	YALE	FS	MONTICELLO
3694	IRV	SB	YALE	FS	IRVINE CENTER
3695	IRV	EB	CIVIC CENTER	NS	HARVARD
3697	IRV	WB	INTERIOR	@	DOCK 1
3698	IRV	WB	INTERIOR	@	DOCK 2
3699	IRV	WB	INTERIOR	@	DOCK 3
3700	IRV	WB	INTERIOR	@	DOCK 4
3701	IRV	EB	INTERIOR	@	DOCK 5
3702	IRV	EB	INTERIOR	@	DOCK 6
3703	IRV	EB	INTERIOR	@	DOCK 7
3704	IRV	EB	INTERIOR	@	DOCK 8
3705	IRV	SB	COLLEGE	FS	IRVINE CENTER
3706	IRV	EB	GREG COPS	@	MAIN ENTRANCE
3707	IRV	WB	INTERIOR	@	MAIN ENTRANCE
3708	IRV	WB	RUTLEDGE	OPP	JOHNSON
3709	LA	EB	1ST	FS	HOPE
3710	LA	EB	4TH	NS	FIGUEROA
3711	LA	WB	5TH	FS	CENTRAL
3712	LA	WB	5TH	NS	TOWNE
3713	LA	WB	5TH	NS	SAN PEDRO
3714	LA	WB	5TH	NS	WALL
3715	LA	WB	5TH	FS	LOS ANGELES
3716	LA	WB	5TH	NS	SPRING
3717	LA	WB	5TH	FS	BROADWAY
3718	LA	WB	5TH	FS	HILL
3719	LA	WB	5TH	FS	GRAND
3720	LA	WB	5TH	NS	FLOWER
3721	LA	EB	6TH	FS	FLOWER
3722	LA	EB	6TH	NS	HILL
3723	LA	EB	6TH	NS	BROADWAY
3724	LA	EB	6TH	FS	MAIN
3725	LA	EB	6TH	NS	WALL
3726	LA	EB	6TH	NS	SAN PEDRO
3727	LA	EB	6TH	NS	TOWNE

Bus Stop Maintenance

RFP 1-3408

All Stop Locations

Exhibit A

Attachment 2

OCTA_ID	CITY	DIR	STREET_OF_TRAVEL	LOC	CROSS_STREET
3728	LA	EB	6TH	NS	GLADYS
3729	LA	EB	6TH	NS	CENTRAL
3730	LA	EB	6TH	NS	MATEO
3731	LA	EB	6TH	NS	BOYLE
3732	LA	WB	6TH	FS	MATEO
3733	LA	WB	6TH	NS	ALAMEDA
3734	LA	EB	8TH	NS	SOTO
3735	LA	NB	BEAUDRY	OPP	5TH
3736	LA	SB	BOYLE	NS	7TH
3737	LA	NB	CENTRAL	FS	6TH
3738	LA	NB	FLOWER	FS	3RD
3739	LA	SB	FLOWER	NS	4TH
3740	LA	SB	FLOWER	FS	5TH
3741	LA	SB	FLOWER	NS	WILSHIRE
3742	LA	SB	FLOWER	NS	7TH
3743	LA	SB	FLOWER	FS	8TH
3744	LA	SB	FLOWER	NS	9TH
3745	LA	SB	FLOWER	NS	OLYMPIC
3746	LA	SB	FLOWER	FS	11TH
3747	LA	NB	FIGUEROA	FS	38TH
3748	LA	NB	FIGUEROA	FS	37TH
3749	LA	NB	FIGUEROA	FS	35TH
3750	LA	NB	FIGUEROA	NS	JEFFERSON
3751	LA	NB	FIGUEROA	NS	30TH
3752	LA	NB	FIGUEROA	FS	ADAMS
3753	LA	NB	FIGUEROA	NS	23RD
3754	LA	NB	FIGUEROA	NS	21ST
3755	LA	NB	FIGUEROA	FS	WASHINGTON
3756	LA	NB	FIGUEROA	NS	VENICE
3757	LA	NB	FIGUEROA	FS	PICO
3758	LA	NB	FIGUEROA	FS	12TH
3759	LA	NB	FIGUEROA	NS	11TH
3760	LA	NB	FIGUEROA	FS	OLYMPIC
3761	LA	NB	FIGUEROA	FS	9TH
3762	LA	NB	FIGUEROA	NS	8TH
3763	LA	NB	FIGUEROA	NS	7TH
3764	LA	NB	FIGUEROA	FS	WILSHIRE
3765	LA	SB	FIGUEROA	NS	12TH
3766	LA	SB	FIGUEROA	FS	PICO
3767	LA	SB	FIGUEROA	FS	VENICE
3768	LA	SB	FIGUEROA	NS	WASHINGTON
3769	LA	SB	FIGUEROA	NS	21ST
3770	LA	SB	FIGUEROA	FS	23RD
3771	LA	SB	FIGUEROA	NS	ADAMS
3772	LA	SB	FIGUEROA	FS	30TH
3773	LA	SB	FIGUEROA	FS	JEFFERSON

Bus Stop Maintenance
All Stop Locations

RFP 1-3408
 Exhibit A
 Attachment 2

OCTA_ID	CITY	DIR	STREET_OF_TRAVEL	LOC	CROSS_STREET
3774	LA	SB	FIGUEROA	FS	35TH
3775	LA	SB	FIGUEROA	NS	EXPOSITION
3776	LA	SB	FIGUEROA	FS	STATE
3777	LA	NB	GRAND	FS	1ST
3778	LA	NB	HOPE	NS	1ST
3779	LA	NB	HOPE	NS	TEMPLE
3780	LA	SB	HOPE	FS	TEMPLE
3781	LA	SB	HOPE	FS	1ST
3782	LA	NB	SOTO	NS	7TH
3783	LA	EB	TEMPLE	FS	GRAND
3784	LA	EB	TEMPLE	FS	HILL
3785	LA	EB	TEMPLE	NS	SPRING
3786	LA	EB	TEMPLE	FS	LOS ANGELES
3787	LA	EB	TEMPLE	FS	JUDGE JOHN AISO
3788	LA	WB	TEMPLE	OPP	SAN PEDRO
3789	LA	WB	TEMPLE	NS	LOS ANGELES
3790	LA	WB	TEMPLE	NS	SPRING
3791	LA	WB	TEMPLE	NS	HILL
3792	LA	WB	WHITTIER	FS	SOTO
3793	LA	WB	WHITTIER	NS	CHICAGO
3794	LA	NB	TRANSIT PLAZA	@	STOP 1
3795	LAGB	NB	COAST	FS	VISTA DEL SOL
3796	LAGB	NB	COAST	NS	10TH
3797	LAGB	NB	COAST	FS	7TH
3798	LAGB	NB	COAST	FS	3RD
3799	LAGB	NB	COAST	NS	CATALINA
3800	LAGB	NB	COAST	FS	WEST
3801	LAGB	NB	COAST	NS	ALISO
3802	LAGB	NB	COAST	FS	WESLEY
3803	LAGB	NB	COAST	FS	ENT 30806 LAGUNA REEF
3804	LAGB	NB	COAST	NS	VICTORIA
3805	LAGB	NB	COAST	FS	SOLANA
3806	LAGB	NB	COAST	OPP	MOSS
3807	LAGB	NB	COAST	FS	DIAMOND
3808	LAGB	NB	COAST	FS	PEARL
3809	LAGB	NB	COAST	FS	BLUEBIRD CANYON
3810	LAGB	NB	COAST	NS	MOUNTAIN
3811	LAGB	NB	COAST	FS	BROOKS
3812	LAGB	NB	COAST	FS	ANITA
3813	LAGB	NB	COAST	FS	SAINT ANNS
3814	LAGB	NB	COAST	FS	CLEO
3815	LAGB	NB	COAST	NS	LEGION
3816	LAGB	NB	COAST	FS	LAGUNA
3817	LAGB	NB	COAST	FS	JASMINE
3818	LAGB	NB	COAST	NS	MYRTLE
3819	LAGB	NB	COAST	FS	BOAT CANYON

Bus Stop Maintenance

RFP 1-3408

All Stop Locations

Exhibit A

Attachment 2

OCTA_ID	CITY	DIR	STREET_OF_TRAVEL	LOC	CROSS_STREET
3820	LAGB	NB	COAST	FS	BEVERLY
3821	LAGB	NB	COAST	FS	FAIRVIEW
3822	LAGB	NB	COAST	FS	CHIQUITA
3823	LAGB	NB	COAST	FS	VIEJO
3824	LAGB	NB	COAST	NS	LEDROIT
3825	LAGB	NB	COAST	FS	ENT EMERALD BAY
3826	LAGB	NB	COAST	FS	ENT IRVINE COVE
3827	OC	NB	COAST	FS	ENT 8811 EL MORRO BEACH
3828	OC	SB	COAST	NS	ENT 8811 EL MORRO BEACH
3829	LAGB	SB	COAST	FS	ENT IRVINE COVE
3830	LAGB	SB	COAST	FS	ENT EMERALD BAY #7
3831	LAGB	SB	COAST	FS	ENT EMERALD BAY #5
3832	LAGB	SB	COAST	FS	CRESCENT BAY
3833	LAGB	SB	COAST	FS	CLIFF
3834	LAGB	SB	COAST	FS	FAIRVIEW
3835	LAGB	SB	COAST	FS	CLIFF
3836	LAGB	SB	COAST	NS	HIGH
3837	LAGB	SB	COAST	FS	MYRTLE
3838	LAGB	SB	COAST	FS	JASMINE
3839	LAGB	SB	COAST	FS	LAGUNA
3840	LAGB	SB	COAST	OPP	LEGION
3841	LAGB	SB	COAST	NS	CLEO
3842	LAGB	SB	COAST	FS	SAINT ANNS
3843	LAGB	SB	COAST	FS	OAK
3844	LAGB	SB	COAST	FS	MOUNTAIN
3845	LAGB	SB	COAST	OPP	BLUEBIRD CANYON
3846	LAGB	SB	COAST	FS	DIAMOND
3847	LAGB	SB	COAST	FS	MOSS
3848	LAGB	SB	COAST	FS	ROCKLEDGE
3849	LAGB	SB	COAST	NS	SUNSET TERRACE
3850	LAGB	SB	COAST	FS	NYES
3851	LAGB	SB	COAST	NS	ENT 30781 BLUE LAGOON
3852	LAGB	SB	COAST	OPP	WESLEY
3853	LAGB	SB	COAST	OPP	ALISO
3854	LAGB	SB	COAST	NS	BLUFF
3855	LAGB	SB	COAST	FS	TABLE ROCK
3856	LAGB	SB	COAST	FS	SEACLIFF
3857	LAGB	SB	COAST	NS	CIRCLE
3858	LAGB	SB	COAST	FS	POINT
3859	LAGB	SB	COAST	FS	VISTA DEL SOL
3860	LAGB	SB	EL TORO	FS	CANYON HILLS
3861	LAGB	SB	EL TORO	FS	THE CLUB
3862	LAGB	SB	EL TORO	VNS	LAGUNA CANYON
3863	LAGB	NB	LAGUNA CANYON	OPP	FESTIVAL OF THE ARTS
3864	LAGB	NB	LAGUNA CANYON	FS	FRONTAGE
3865	LAGB	NB	LAGUNA CANYON	NS	WOODLAND

Bus Stop Maintenance

RFP 1-3408

All Stop Locations

Exhibit A

Attachment 2

OCTA_ID	CITY	DIR	STREET_OF_TRAVEL	LOC	CROSS_STREET
3866	LAGB	NB	LAGUNA CANYON	FS	CANYON ACRES
3867	LAGB	NB	LAGUNA CANYON	FS	ENT 1765 LAGUNA BEACH
3868	LAGB	NB	LAGUNA CANYON	FS	ENT 2295 LAGUNA CANYON
3869	LAGB	NB	LAGUNA CANYON	FS	STAN OAKS
3870	LAGB	NB	LAGUNA CANYON	NS	SUN VALLEY
3871	LAGB	NB	LAGUNA CANYON	NS	EL TORO
3872	LAGB	SB	LAGUNA CANYON	FS	ENT 20101 LAGUNA COAST
3873	LAGB	SB	LAGUNA CANYON	OPP	SUN VALLEY
3874	LAGB	SB	LAGUNA CANYON	OPP	STAN OAKS
3875	LAGB	SB	LAGUNA CANYON	FS	ENT 2222 ART INSTITUTE
3876	LAGB	SB	LAGUNA CANYON	OPP	ENT 1765 LAGUNA BEACH
3877	LAGB	SB	LAGUNA CANYON	OPP	CANYON ACRES
3878	LAGB	SB	LAGUNA CANYON	NS	FESTIVAL OF THE ARTS
3879	LAGB	NB	BROADWAY	FS	COAST
3880	LAGB	NB	BROADWAY	@	LAGUNA BEACH BUS STATION
3881	LAGB	WB	INTERIOR	FS	OCEAN
3882	LAGH	NB	ALICIA	FS	RAMONA
3883	LAGH	NB	ALICIA	NS	MOULTON
3884	LAGH	NB	ALICIA	FS	ALISO HILLS
3885	LAGH	NB	ALICIA	OPP	COMMUNITY CENTER
3886	LAGH	NB	ALICIA	VFS	PASEO DE VALENCIA
3887	LAGH	NB	ALICIA	FS	WILKES
3888	LAGH	NB	ALICIA	FS	COSTEAU
3889	LAGH	NB	ALICIA	NS	PASEO DE ALICIA
3890	LAGH	SB	ALICIA	FS	HON
3891	LAGH	SB	ALICIA	FS	COSTEAU
3892	LAGH	SB	ALICIA	FS	WILKES
3893	LAGH	SB	ALICIA	FS	PASEO DE VALENCIA
3894	LAGH	SB	ALICIA	OPP	ALISO HILLS
3895	LAGH	SB	ALICIA	NS	MOULTON
3896	LAGH	NB	AVD DE LA CARLOTA	FS	LOS ALISOS
3897	LAGH	NB	AVD DE LA CARLOTA	NS	PLAZA
3898	LAGH	SB	AVD DE LA CARLOTA	FS	EL TORO
3899	LAGH	SB	AVD DE LA CARLOTA	FS	SOUTH ENTRANCE
3900	LAGH	SB	AVD DE LA CARLOTA	NS	ENT 24231 OAKBROOK
3901	LAGH	NB	CABOT	NS	OSO
3902	LAGH	NB	CABOT	FS	EL PASEO
3903	LAGH	NB	CABOT	VNS	LA PAZ
3904	LAGH	SB	CABOT	FS	LA PAZ
3905	LAGH	SB	CABOT	NS	PASEO DE VALENCIA
3906	LAGH	SB	CABOT	FS	NELLIE GAIL
3907	LAGH	SB	CABOT	OPP	EL PASEO
3908	LAGH	SB	CABOT	NS	OSO
3909	LAGH	SB	CABOT	FS	RAPID FALLS
3910	LAGH	EB	EL TORO	FS	PASEO DE VALENCIA
3911	LAGH	EB	EL TORO	FS	REGIONAL CENTER

Bus Stop Maintenance**All Stop Locations**

RFP 1-3408

Exhibit A

Attachment 2

OCTA_ID	CITY	DIR	STREET_OF_TRAVEL	LOC	CROSS_STREET
3912	LAGH	NB	LA PAZ	FS	PASEO DE VALENCIA
3913	LAGH	NB	LA PAZ	FS	MCINTYRE
3914	LAGH	SB	LA PAZ	OPP	CABOT
3915	LAGH	SB	LA PAZ	FS	MCINTYRE
3916	LAGH	SB	LA PAZ	OPP	CHAMPLAIN
3917	LAGH	NB	LOS ALISOS	NS	WOODCREEK
3918	LAGH	NB	MOULTON	FS	NELLIE GAIL
3919	LAGH	NB	MOULTON	FS	OSO
3920	LAGH	NB	MOULTON	FS	LA PAZ
3921	LAGH	NB	MOULTON	FS	MANDEVILLE
3922	LAGH	NB	MOULTON	FS	ALICIA
3923	LAGH	NB	MOULTON	FS	RIDGE ROUTE
3924	LAGH	NB	MOULTON	FS	EL PACIFICO
3925	LAGH	NB	MOULTON	OPP	GRANITE
3926	LAGH	NB	MOULTON	VNS	LAKE FOREST
3927	LAGH	SB	MOULTON	FS	LAKE FOREST
3928	LAGH	SB	MOULTON	FS	GRANITE
3929	LAGH	SB	MOULTON	NS	LAKE HILLS CHURCH
3930	LAGH	SB	MOULTON	FS	RIDGE ROUTE
3931	LAGH	SB	MOULTON	FS	VIA LOMAS
3932	LAGH	SB	MOULTON	FS	ALICIA
3933	LAGH	SB	MOULTON	OPP	MANDEVILLE
3934	LAGH	SB	MOULTON	FS	LOUISA
3935	LAGH	SB	MOULTON	FS	LA PAZ
3936	LAGH	SB	MOULTON	VFS	OSO
3937	LAGH	NB	PASEO DE VALENCIA	FS	PINENUT
3938	LAGH	NB	PASEO DE VALENCIA	FS	MACKENZIE
3939	LAGH	NB	PASEO DE VALENCIA	FS	LA PAZ
3940	LAGH	NB	PASEO DE VALENCIA	FS	ERICSON
3941	LAGH	NB	PASEO DE VALENCIA	FS	VELAZQUEZ
3942	LAGH	NB	PASEO DE VALENCIA	FS	HILLARY
3943	LAGH	NB	PASEO DE VALENCIA	FS	ALICIA
3944	LAGH	NB	PASEO DE VALENCIA	FS	STOCKPORT
3945	LAGH	NB	PASEO DE VALENCIA	FS	BECKENHAM
3946	LAGH	NB	PASEO DE VALENCIA	FS	LOS ALISOS
3947	LAGH	WB	PASEO DE VALENCIA	FS	HEALTH CENTER
3948	LAGH	WB	PASEO DE VALENCIA	FS	CALLE DE LA PLATA
3949	LAGH	WB	PASEO DE VALENCIA	FS	CALLE DE LA MAGDALENA
3950	LAGH	SB	PASEO DE VALENCIA	FS	LAGUNA HILLS
3951	LAGH	SB	PASEO DE VALENCIA	FS	ALICIA
3952	LAGH	SB	PASEO DE VALENCIA	OPP	HILLARY
3953	LAGH	SB	PASEO DE VALENCIA	FS	ALISAL
3954	LAGH	SB	PASEO DE VALENCIA	OPP	ERICSON
3955	LAGH	SB	PASEO DE VALENCIA	FS	LA PAZ
3956	LAGH	SB	PASEO DE VALENCIA	FS	VISTA FIRENZE
3957	LAGH	SB	PASEO DE VALENCIA	OPP	PINENUT

Bus Stop Maintenance

All Stop Locations

RFP 1-3408

Exhibit A

Attachment 2

OCTA_ID	CITY	DIR	STREET_OF_TRAVEL	LOC	CROSS_STREET
3958	LAGH	SB	SAN REMO	OPP	RIMINI
3959	LAGH	SB	SAN REMO	FS	TERAMO
3960	LAGH	NB	SAN REMO	NS	RIMINI
3961	LAGH	NB	SAN REMO	NS	TARANTO
3962	LAGH	WB	SANTA MARIA	FS	MOULTON
3963	LAGH	SB	SANTA VITTORIA	NS	BASSANO WEST
3964	LAGH	SB	SANTA VITTORIA	FS	CAMINO JALISCO
3965	LAGH	SB	SANTA VITTORIA	OPP	AVD CENTINELA
3966	LAGH	SB	SANTA VITTORIA	NS	CAMINO JALISCO
3967	LAGH	SB	SANTA VITTORIA	FS	CAMINITO CRUZ
3968	LAGH	NB	SANTA VITTORIA	FS	SAN REMO
3969	LAGH	NB	SANTA VITTORIA	FS	RIDGE ROUTE
3970	LAGH	NB	SANTA VITTORIA	FS	AVD COPETE
3971	LAGH	NB	SANTA VITTORIA	OPP	CAMINO JALISCO
3972	LAGH	NB	SANTA VITTORIA	NS	BASSANO EAST
3973	LAGH	SB	LOS ALISOS	FS	AVD DE LA CARLOTA
3974	LAGH	NB	LOS ALISOS	FS	AVD DE LA CARLOTA
3975	LAGH	SB	CALLE DE LA LOUISA	VFS	CALLE DE LA PLATA
3976	LAGH	SB	CALLE DE LA LOUISA	FS	HEALTH CENTER
3977	LAGH	NB	CALLE DE LA LOUISA	OPP	HEALTH CENTER
3978	LAGH	NB	CALLE DE LA LOUISA	VNS	CALLE DE LA PLATA
3979	LAGH	NB	CALLE DE LA PLATA	FS	PASEO DE VALENCIA
3980	LAGH	WB	PASEO DE VALENCIA	NS	CALLE DE LOS CABALLEROS
3981	LAGH	WB	PASEO DE VALENCIA	NS	CALLE DE LOS CABALLEROS
3982	LAGH	SB	LHTC	@	DOCK 3
3983	LAGH	SB	LHTC	@	DOCK 4
3984	LAGH	SB	LHTC	@	DOCK 5
3985	LAGH	SB	LHTC	@	DOCK 6
3986	LAGH	SB	LHTC	@	DOCK 7
3987	LAGH	EB	LHTC	@	DOCK 8
3988	LAGH	EB	LHTC	@	DOCK 9
3989	LAGH	EB	LHTC	@	DOCK 10
3990	LAGH	NB	CALLE DE LOS CABALLEROS	OPP	CALLE DE LA LOUISA
3991	LAGH	NB	CALLE DE LOS CABALLEROS	FS	PASEO DE VALENCIA
3992	LB	EB	7TH	FS	ALAMITOS
3993	LB	EB	7TH	FS	CERRITOS
3994	LB	EB	7TH	FS	ORANGE
3995	LB	EB	7TH	FS	NEBRASKA
3996	LB	EB	7TH	FS	WALNUT
3997	LB	EB	7TH	FS	ROSE
3998	LB	EB	7TH	FS	CHERRY
3999	LB	EB	7TH	FS	DAWSON
4000	LB	EB	7TH	FS	JUNIPERO
4001	LB	EB	7TH	FS	MOLINO
4002	LB	EB	7TH	FS	TEMPLE
4003	LB	EB	7TH	FS	ORIZABA

Bus Stop Maintenance

RFP 1-3408

All Stop Locations

Exhibit A

Attachment 2

OCTA_ID	CITY	DIR	STREET_OF_TRAVEL	LOC	CROSS_STREET
4004	LB	EB	7TH	FS	OBISPO
4005	LB	EB	7TH	FS	REDONDO
4006	LB	EB	7TH	FS	EUCLID
4007	LB	EB	7TH	FS	TERMINO
4008	LB	EB	7TH	FS	ROSWELL
4009	LB	EB	7TH	FS	XIMENO
4010	LB	EB	7TH	FS	PARK
4011	LB	EB	7TH	NS	FEDERATION
4012	LB	EB	7TH	FS	TERRAINE
4013	LB	EB	7TH	FS	LOS ALTOS
4014	LB	EB	7TH	NS	BELLFLOWER
4015	LB	EB	1ST	FS	THE PROMENADE
4016	LB	EB	1ST	NS	ELM
4017	LB	EB	6TH	FS	LONG BEACH
4018	LB	EB	6TH	FS	ELM
4019	LB	EB	6TH	FS	LINDEN
4020	LB	EB	6TH	FS	ATLANTIC
4021	LB	EB	6TH	FS	OLIVE
4022	LB	EB	7TH	VFS	CHANNEL
4023	LB	EB	7TH	OPP	WEST CAMPUS
4024	LB	WB	7TH	VFS	EAST CAMPUS
4025	LB	WB	7TH	NS	WEST CAMPUS
4026	LB	WB	7TH	OPP	CHANNEL
4027	LB	WB	7TH	FS	PACIFIC COAST
4028	LB	WB	7TH	FS	LOS ALTOS
4029	LB	WB	7TH	FS	FEDERATION
4030	LB	WB	7TH	FS	PARK
4031	LB	WB	7TH	FS	XIMENO
4032	LB	WB	7TH	FS	ROSWELL
4033	LB	WB	7TH	FS	TERMINO
4034	LB	WB	7TH	NS	EUCLID
4035	LB	WB	7TH	FS	REDONDO
4036	LB	WB	7TH	FS	OBISPO
4037	LB	WB	7TH	FS	ORIZABA
4038	LB	WB	7TH	FS	TEMPLE
4039	LB	WB	7TH	FS	MOLINO
4040	LB	WB	7TH	FS	JUNIPERO
4041	LB	WB	7TH	FS	DAWSON
4042	LB	WB	7TH	FS	CHERRY
4043	LB	WB	7TH	FS	ROSE
4044	LB	WB	7TH	FS	WALNUT
4045	LB	WB	7TH	OPP	NEBRASKA
4046	LB	WB	7TH	FS	ORANGE
4047	LB	WB	7TH	FS	CERRITOS
4048	LB	WB	7TH	FS	OLIVE
4049	LB	WB	7TH	FS	ATLANTIC

Bus Stop Maintenance

RFP 1-3408

All Stop Locations

Exhibit A

Attachment 2

OCTA_ID	CITY	DIR	STREET_OF_TRAVEL	LOC	CROSS_STREET
4050	LB	WB	7TH	FS	LINDEN
4051	LB	WB	7TH	FS	ELM
4052	LB	WB	7TH	FS	LONG BEACH
4053	LB	WB	7TH	FS	LOCUST
4054	LB	SB	BLOOMFIELD	FS	WOODSON
4055	LB	SB	BLOOMFIELD	FS	LITTLEFIELD
4056	LB	SB	CHANNEL	FS	7TH
4057	LB	NB	LONG BEACH	NS	3RD
4058	LB	NB	LONG BEACH	NS	4TH
4059	LB	NB	LONG BEACH	NS	5TH
4060	LB	NB	NORWALK	FS	WARDLOW
4061	LB	NB	NORWALK	FS	TORIN
4062	LB	NB	NORWALK	NS	WOODSON
4063	LB	SB	NORWALK	FS	RING
4064	LB	SB	NORWALK	NS	WARDLOW
4065	LB	SB	PACIFIC	FS	7TH
4066	LB	SB	PACIFIC	FS	6TH
4067	LB	SB	PACIFIC	FS	5TH
4068	LB	SB	PACIFIC	FS	3RD
4069	LB	NB	PACIFIC COAST	OPP	STUDEBAKER
4070	LB	NB	PACIFIC COAST	VNS	WESTMINSTER
4071	LB	NB	PACIFIC COAST	FS	WESTMINSTER
4072	LB	NB	PACIFIC COAST	FS	ENT 6285 GOLDEN SAIL
4073	LB	NB	PACIFIC COAST	FS	LOYNES
4074	LB	NB	PACIFIC COAST	FS	7TH
4075	LB	NB	PACIFIC COAST	NS	LOS ALTOS PLAZA
4076	LB	NB	PACIFIC COAST	FS	CLARK
4077	LB	NB	PACIFIC COAST	NS	PARK
4078	LB	SB	PACIFIC COAST	FS	XIMENO
4079	LB	SB	PACIFIC COAST	FS	CLARK
4080	LB	SB	PACIFIC COAST	FS	ANAHEIM
4081	LB	SB	PACIFIC COAST	FS	SANTIAGO
4082	LB	SB	PACIFIC COAST	FS	LOYNES
4083	LB	SB	PACIFIC COAST	OPP	ENT 6285 GOLDEN SAIL
4084	LB	SB	PACIFIC COAST	FS	MARNIA PACIFIC MALL
4085	LB	SB	PACIFIC COAST	FS	2ND
4086	LB	SB	PACIFIC COAST	FS	STUDEBAKER
4087	LB	NB	STUDEBAKER	FS	WESTMINSTER
4088	LB	NB	STUDEBAKER	OPP	LOYNES
4089	LB	NB	STUDEBAKER	FS	ANAHEIM
4090	LB	NB	STUDEBAKER	FS	MANTOVA
4091	LB	NB	STUDEBAKER	FS	DRISCOLL
4092	LB	NB	STUDEBAKER	FS	ATHERTON
4093	LB	NB	STUDEBAKER	FS	LOS SANTOS
4094	LB	NB	STUDEBAKER	VFS	STEARNS
4095	LB	NB	STUDEBAKER	OPP	EL SALVADOR

Bus Stop Maintenance

All Stop Locations

RFP 1-3408

Exhibit A

Attachment 2

OCTA_ID	CITY	DIR	STREET_OF_TRAVEL	LOC	CROSS_STREET
4096	LB	NB	STUDEBAKER	OPP	LOS ARCOS
4097	LB	NB	STUDEBAKER	NS	WILLOW
4098	LB	SB	STUDEBAKER	FS	WILLOW
4099	LB	SB	STUDEBAKER	FS	LOS ARCOS
4100	LB	SB	STUDEBAKER	FS	LA MARIMBA
4101	LB	SB	STUDEBAKER	FS	STEARNS
4102	LB	SB	STUDEBAKER	FS	LOS SANTOS
4103	LB	SB	STUDEBAKER	FS	ATHERTON
4104	LB	SB	STUDEBAKER	FS	DRISCOLL
4105	LB	SB	STUDEBAKER	FS	VUELTA GRANDE
4106	LB	SB	STUDEBAKER	FS	ANAHEIM
4107	LB	SB	STUDEBAKER	NS	LOYNES
4108	LB	EB	WARDLOW	FS	NORWALK
4109	LB	EB	WESTMINSTER	FS	PACIFIC COAST
4110	LB	EB	WESTMINSTER	NS	SHOPKEEPER
4111	LB	EB	WESTMINSTER	OPP	STUDEBAKER
4112	LB	EB	WESTMINSTER	OPP	ENT 6801 HAYNES
4113	LB	EB	WESTMINSTER	FS	ISLAND VILLAGE
4114	LB	WB	WESTMINSTER	OPP	ISLAND VILLAGE
4115	LB	WB	WESTMINSTER	NS	ENT 6801 HAYNES
4116	LB	WB	WESTMINSTER	OPP	SHOPKEEPER
4117	LF	NB	ALTON	FS	TOWNE CENTER
4118	LF	NB	BAKE	FS	JERONIMO
4119	LF	NB	BAKE	FS	TOLEDO
4120	LF	NB	BAKE	FS	CALLE ENTRADA
4121	LF	NB	BAKE	FS	TRABUCO
4122	LF	NB	BAKE	VNS	SOUTH POINTE
4123	LF	NB	BAKE	FS	SOUTH POINTE
4124	LF	NB	BAKE	FS	NORTH POINTE
4125	LF	NB	BAKE	FS	DIMENSION
4126	LF	NB	BAKE	FS	TOWNE CENTER
4127	LF	NB	BAKE	FS	PORTOLA
4128	LF	SB	BAKE	FS	PORTOLA
4129	LF	SB	BAKE	FS	TOWNE CENTER
4130	LF	SB	BAKE	FS	COMMERCENTRE
4131	LF	SB	BAKE	FS	CRESCENT BAY
4132	LF	SB	BAKE	FS	NORTH POINT
4133	LF	SB	BAKE	FS	CAPITAL
4134	OC	SB	BAKE	FS	SOUTH POINTE
4135	LF	EB	COMMERCENTRE	FS	BAKE
4136	LF	EB	COMMERCENTRE	FS	BISCAYNE BAY
4137	LF	EB	COMMERCENTRE	FS	ENT 25800 PACIFIC
4138	LF	WB	COMMERCENTRE	FS	DIMENSION
4139	LF	WB	COMMERCENTRE	FS	ENT 25841 THE YOUNG
4140	LF	WB	COMMERCENTRE	FS	BISCAYNE BAY
4141	LF	NB	DIMENSION	FS	COMMERCENTRE

Bus Stop Maintenance

RFP 1-3408

All Stop Locations

Exhibit A

Attachment 2

OCTA_ID	CITY	DIR	STREET_OF_TRAVEL	LOC	CROSS_STREET
4142	LF	NB	DIMENSION	FS	ENTERPRISE
4143	LF	SB	DIMENSION	NS	ATLANTIC OCEAN
4144	LF	NB	EL TORO	NS	SWARTZ
4145	LF	NB	EL TORO	NS	ROCKFIELD
4146	LF	NB	EL TORO	NS	ORCHARDS
4147	LF	NB	EL TORO	FS	CORNELIUS
4148	LF	NB	EL TORO	FS	MUIRLANDS
4149	LF	NB	EL TORO	FS	JERONIMO
4150	LF	NB	EL TORO	NS	TOLEDO
4151	LF	NB	EL TORO	NS	SERRANO
4152	LF	NB	EL TORO	NS	TRABUCO
4153	LF	NB	EL TORO	NS	ALISO PARK
4154	LF	NB	EL TORO	OPP	NORTHCREST
4155	LF	NB	EL TORO	FS	RAINTREE
4156	LF	NB	EL TORO	FS	DESTRY
4157	LF	NB	EL TORO	FS	NORMANDALE
4158	LF	NB	EL TORO	NS	SANTA MARGARITA
4159	LF	SB	EL TORO	FS	SANTA MARGARITA
4160	LF	SB	EL TORO	FS	NORMANDALE
4161	LF	SB	EL TORO	FS	NORTHCREST
4162	LF	SB	EL TORO	FS	ALISO PARK
4163	LF	SB	EL TORO	FS	TRABUCO
4164	LF	SB	EL TORO	FS	SERRANO
4165	LF	SB	EL TORO	NS	TOLEDO
4166	LF	SB	EL TORO	FS	JERONIMO
4167	LF	SB	EL TORO	NS	RATON
4168	LF	SB	EL TORO	FS	MUIRLANDS
4169	LF	SB	EL TORO	FS	JUTEWOOD
4170	LF	SB	EL TORO	NS	RAYMOND
4171	LF	SB	EL TORO	VNS	ROCKFIELD
4172	LF	NB	ELLIPSE	OPP	ENT 20081 IPC
4173	LF	WB	ICON	VFS	DEFINITION
4174	LF	WB	ICON	NS	ELLIPSE
4175	LF	EB	JERONIMO	FS	BAKE
4176	LF	EB	JERONIMO	NS	HEIDI
4177	LF	EB	JERONIMO	FS	LAKE FOREST
4178	LF	EB	JERONIMO	FS	EXIT 24600 SERRANO
4179	LF	EB	JERONIMO	NS	ELDAMAR
4180	LF	EB	JERONIMO	FS	RIDGE ROUTE
4181	LF	EB	JERONIMO	OPP	CANARD
4182	LF	EB	JERONIMO	NS	FARTHING
4183	LF	EB	JERONIMO	FS	EL TORO
4184	LF	EB	JERONIMO	FS	CHERRY
4185	LF	WB	JERONIMO	FS	LOS ALISOS
4186	LF	WB	JERONIMO	FS	CHERRY
4187	LF	WB	JERONIMO	FS	EL TORO

Bus Stop Maintenance

RFP 1-3408

All Stop Locations

Exhibit A

Attachment 2

OCTA_ID	CITY	DIR	STREET_OF_TRAVEL	LOC	CROSS_STREET
4188	LF	WB	JERONIMO	FS	RIDGE ROUTE
4189	LF	WB	JERONIMO	OPP	ENT 24600 SERRANO
4190	LF	WB	JERONIMO	FS	PARKWOOD
4191	LF	WB	JERONIMO	FS	LAKE FOREST
4192	LF	WB	JERONIMO	FS	JERONIMO
4193	LF	WB	JERONIMO	FS	JERONIMO
4194	LF	NB	LAKE FOREST	FS	MUIRLANDS
4195	LF	NB	LAKE FOREST	FS	OVERLAKE
4196	LF	NB	LAKE FOREST	FS	JERONIMO
4197	LF	NB	LAKE FOREST	FS	TOLEDO
4198	LF	NB	LAKE FOREST	FS	BUFFWOOD
4199	LF	NB	LAKE FOREST	NS	SERRANO
4200	LF	NB	LAKE FOREST	FS	TRABUCO
4201	LF	NB	LAKE FOREST	FS	NEWVALE
4202	LF	NB	LAKE FOREST	NS	FERNLEAF
4203	LF	NB	LAKE FOREST	FS	PITTSFORD
4204	LF	NB	LAKE FOREST	FS	VINTAGE WOODS
4205	LF	NB	LAKE FOREST	OPP	DIMENSION
4206	LF	NB	LAKE FOREST	FS	REGENCY
4207	LF	NB	LAKE FOREST	FS	VISTA TERRACE
4208	LF	NB	LAKE FOREST	FS	PORTOLA
4209	LF	NB	LAKE FOREST	OPP	BURBANK
4210	LF	SB	LAKE FOREST	FS	BURBANK
4211	LF	SB	LAKE FOREST	FS	PORTOLA
4212	LF	SB	LAKE FOREST	FS	TOWNE CENTRE
4213	LF	SB	LAKE FOREST	OPP	RANCHO
4214	LF	SB	LAKE FOREST	OPP	VISTA TERRACE
4215	LF	SB	LAKE FOREST	OPP	REGENCY
4216	LF	SB	LAKE FOREST	FS	DIMENSION
4217	LF	SB	LAKE FOREST	FS	VINTAGE WOODS
4218	LF	SB	LAKE FOREST	FS	PITTSFORD
4219	LF	SB	LAKE FOREST	FS	STERLING
4220	LF	SB	LAKE FOREST	FS	CANADA
4221	LF	SB	LAKE FOREST	FS	TRABUCO
4222	LF	SB	LAKE FOREST	FS	SERRANO
4223	LF	SB	LAKE FOREST	OPP	BUFFWOOD
4224	LF	SB	LAKE FOREST	FS	TOLEDO
4225	LF	SB	LAKE FOREST	FS	JERONIMO
4226	LF	SB	LAKE FOREST	OPP	OVERLAKE
4227	LF	NB	LOS ALISOS	FS	FORDVIEW
4228	LF	SB	LOS ALISOS	FS	MUIRLANDS
4229	LF	SB	LOS ALISOS	FS	ROCKFIELD
4230	LF	NB	MARKET	FS	TOWNE CENTER
4231	LF	SB	MARKET	FS	PORTOLA
4232	LF	EB	MUIRLANDS	FS	ASPAN
4233	LF	EB	MUIRLANDS	FS	LAKE FOREST

Bus Stop Maintenance
All Stop Locations

RFP 1-3408
Exhibit A
Attachment 2

OCTA_ID	CITY	DIR	STREET_OF_TRAVEL	LOC	CROSS_STREET
4234	LF	EB	MUIRLANDS	NS	DYLAN
4235	LF	EB	MUIRLANDS	FS	RIDGE ROUTE
4236	LF	EB	MUIRLANDS	FS	ENTRADOS
4237	LF	EB	MUIRLANDS	FS	TULIP
4238	LF	EB	MUIRLANDS	FS	EL TORO
4239	LF	EB	MUIRLANDS	FS	PARKVIEW
4240	LF	WB	MUIRLANDS	FS	LOS ALISOS
4241	LF	WB	MUIRLANDS	FS	PARKVIEW
4242	LF	WB	MUIRLANDS	FS	EL TORO
4243	LF	WB	MUIRLANDS	FS	TULIP
4244	LF	WB	MUIRLANDS	FS	ENTRADOS
4245	LF	WB	MUIRLANDS	FS	RIDGE ROUTE
4246	LF	WB	MUIRLANDS	OPP	DYLAN
4247	LF	WB	MUIRLANDS	OPP	OSWEGO
4248	LF	WB	MUIRLANDS	FS	LAKE FOREST
4249	LF	WB	MUIRLANDS	OPP	ASPAN
4250	LF	WB	MUIRLANDS	FS	FERNGREEN
4251	LF	EB	PORTOLA	FS	MARKET
4252	LF	EB	PORTOLA	FS	BAKE
4253	LF	EB	PORTOLA	FS	LAKE FOREST
4255	LF	EB	PORTOLA	FS	TOWNE CENTER
4256	LF	WB	PORTOLA	FS	PAULING
4257	LF	WB	PORTOLA	FS	BAKE
4258	LF	NB	RIDGE ROUTE	FS	ROCKFIELD
4259	LF	NB	RIDGE ROUTE	FS	EL ROND
4260	LF	NB	RIDGE ROUTE	FS	JERONIMO
4261	LF	NB	RIDGE ROUTE	FS	COSTA BELLA
4262	LF	NB	RIDGE ROUTE	FS	TOLEDO
4263	LF	NB	RIDGE ROUTE	NS	SERRANO
4264	LF	NB	RIDGE ROUTE	FS	CHAPARRAL
4265	LF	SB	RIDGE ROUTE	FS	SERRANO
4266	LF	SB	RIDGE ROUTE	FS	TOLEDO
4267	LF	SB	RIDGE ROUTE	OPP	COSTA BELLA
4268	LF	SB	RIDGE ROUTE	FS	MUIRLANDS
4269	LF	SB	RIDGE ROUTE	FS	EL ROND
4270	LF	SB	RIDGE ROUTE	NS	ROCKFIELD
4271	LF	EB	ROCKFIELD	FS	LAKE FOREST
4272	LF	EB	ROCKFIELD	FS	BOEING
4273	LF	EB	ROCKFIELD	FS	MERCURY
4274	LF	EB	ROCKFIELD	FS	RIDGE ROUTE
4275	LF	EB	ROCKFIELD	OPP	DURYEA
4276	LF	EB	ROCKFIELD	OPP	CAVANAUGH
4277	LF	EB	ROCKFIELD	NS	EL TORO
4278	LF	EB	ROCKFIELD	FS	EL TORO
4279	LF	EB	ROCKFIELD	FS	LANDISVIEW
4280	LF	WB	ROCKFIELD	FS	LARKWOOD

Bus Stop Maintenance

RFP 1-3408

All Stop Locations

Exhibit A

Attachment 2

OCTA_ID	CITY	DIR	STREET_OF_TRAVEL	LOC	CROSS_STREET
4281	LF	WB	ROCKFIELD	FS	LANDISVIEW
4282	LF	WB	ROCKFIELD	FS	EL TORO
4283	LF	WB	ROCKFIELD	FS	DURYEA
4284	LF	WB	ROCKFIELD	NS	RIDGE ROUTE
4285	LF	WB	ROCKFIELD	OPP	MERCURY
4286	LF	WB	ROCKFIELD	FS	BOEING
4287	LF	WB	ROCKFIELD	FS	LAKE FOREST
4288	LF	EB	TOWNE CENTER	FS	ALTON
4289	LF	WB	TOWNE CENTER	FS	MARKET
4290	LF	EB	TRABUCO	FS	BAKE
4291	LF	EB	TRABUCO	OPP	PEACHWOOD
4292	LF	EB	TRABUCO	FS	LAKE FOREST
4293	LF	EB	TRABUCO	NS	RIDGE ROUTE
4294	LF	EB	TRABUCO	FS	EL TORO
4295	LF	WB	TRABUCO	FS	EL TORO
4296	LF	WB	TRABUCO	FS	RED RIVER
4297	LF	WB	TRABUCO	FS	LAKE FOREST
4298	LF	WB	TRABUCO	FS	PEACHWOOD
4299	LF	WB	TRABUCO	FS	PASEO TRANQUILO
4300	LF	WB	TRABUCO	NS	PASEO SOMBRA
4301	LH	NB	BEACH	OPP	1501 HILLSBOROUGH PARK
4302	LH	NB	BEACH	FS	WESTRIDGE PLAZA SOUTH
4303	LH	NB	BEACH	FS	IMPERIAL
4304	LH	NB	BEACH	NS	FASHION SQUARE
4305	LH	NB	BEACH	FS	FASHION SQUARE
4306	LH	NB	BEACH	FS	LAMBERT
4307	LH	NB	BEACH	FS	MERCED
4308	LH	NB	BEACH	FS	LA HABRA
4309	LH	NB	BEACH	VFS	LA HABRA
4310	LH	NB	BEACH	NS	GREGORY
4311	LH	NB	BEACH	VNS	WHITTIER
4312	LH	SB	BEACH	FS	LA HABRA
4313	LH	SB	BEACH	FS	MERCED
4314	LH	SB	BEACH	FS	LAMBERT
4315	LH	SB	BEACH	OPP	FASHION SQUARE
4316	LH	SB	BEACH	FS	IMPERIAL
4317	LH	SB	BEACH	OPP	WESTRIDGE PLAZA SOUTH
4318	LH	SB	BEACH	FS	1501 HILLSBOROUGH PARK
4319	LH	NB	EUCLID	FS	COUNTRY HILLS
4320	LH	NB	EUCLID	FS	MONTWOOD
4321	LH	NB	EUCLID	NS	IMPERIAL
4322	LH	NB	EUCLID	FS	INDUSTRY
4323	LH	NB	EUCLID	OPP	LAS LOMAS
4324	LH	NB	EUCLID	FS	LAMBERT
4325	LH	NB	EUCLID	FS	ELECTRIC
4326	LH	NB	EUCLID	NS	LA HABRA

Bus Stop Maintenance

RFP 1-3408

All Stop Locations

Exhibit A

Attachment 2

OCTA_ID	CITY	DIR	STREET_OF_TRAVEL	LOC	CROSS_STREET
4327	LH	WB	1ST	NS	EUCLID
4328	LH	SB	EUCLID	NS	ELECTRIC
4329	LH	SB	EUCLID	NS	LAMBERT
4330	LH	SB	EUCLID	NS	LAS LOMAS
4331	LH	SB	EUCLID	FS	IMPERIAL
4332	LH	SB	EUCLID	NS	MONTWOOD
4333	LH	NB	HARBOR	FS	LAS PALMAS
4334	LH	NB	HARBOR	FS	LAS RIENDAS
4335	LH	NB	HARBOR	FS	LAMBERT
4336	LH	NB	HARBOR	NS	SUPERIOR
4337	LH	NB	HARBOR	FS	LA HABRA
4338	LH	NB	HARBOR	FS	FRANCIS
4339	LH	SB	HARBOR	FS	WHITTIER
4340	LH	SB	HARBOR	NS	STEARNS
4341	LH	SB	HARBOR	FS	LA HABRA
4342	LH	SB	HARBOR	NS	3RD
4343	LH	SB	HARBOR	FS	LAMBERT
4344	LH	SB	HARBOR	FS	EDWARDS
4345	LH	SB	HARBOR	FS	IMPERIAL
4346	LH	SB	IDAHO	OPP	LAS LOMAS
4347	LH	SB	IDAHO	FS	WHITTIER
4348	LH	SB	IDAHO	OPP	HIGHLANDER
4349	LH	EB	IMPERIAL	FS	IDAHO
4350	LH	EB	IMPERIAL	NS	EUCLID
4351	LH	EB	IMPERIAL	NS	LAKEVIEW
4352	LH	WB	IMPERIAL	FS	LESLIE
4353	LH	WB	IMPERIAL	FS	EUCLID
4354	LH	WB	IMPERIAL	FS	WALNUT
4355	LH	WB	IMPERIAL	FS	IDAHO
4356	LH	WB	IMPERIAL	FS	MARKET PLACE
4357	LH	WB	IMPERIAL	NS	MARKET PLACE
4358	LH	EB	LA HABRA	FS	DEXFORD
4359	LH	EB	LA HABRA	FS	BEACH
4360	LH	EB	LA HABRA	OPP	EL PORTAL
4361	LH	EB	LA HABRA	NS	IDAHO
4362	LH	EB	LA HABRA	NS	MONTE VISTA
4363	LH	EB	LA HABRA	NS	WALNUT
4364	LH	EB	LA HABRA	NS	EUCLID
4365	LH	EB	LA HABRA	NS	CYPRESS
4366	LH	EB	LA HABRA	FS	MCPHERSON
4367	LH	EB	LA HABRA	FS	VALENCIA
4368	LH	EB	LA HABRA	NS	HARBOR
4369	LH	EB	LA HABRA	NS	FONDA
4370	LH	WB	LA HABRA	FS	PALM
4371	LH	WB	LA HABRA	FS	FONDA
4372	LH	WB	LA HABRA	FS	HARBOR

Bus Stop Maintenance

All Stop Locations

RFP 1-3408

Exhibit A

Attachment 2

OCTA_ID	CITY	DIR	STREET_OF_TRAVEL	LOC	CROSS_STREET
4373	LH	WB	LA HABRA	NS	VALENCIA
4374	LH	WB	LA HABRA	NS	MCPHERSON
4375	LH	WB	LA HABRA	FS	CYPRESS
4376	LH	WB	LA HABRA	FS	EUCLID
4377	LH	WB	LA HABRA	NS	WALNUT
4378	LH	WB	LA HABRA	FS	MONTE VISTA
4379	LH	WB	LA HABRA	FS	IDAHO
4380	LH	WB	LA HABRA	FS	EL PORTAL
4381	LH	WB	LA HABRA	FS	BEACH
4382	LH	WB	LA HABRA	FS	DEXFORD
4383	LH	WB	LA HABRA	NS	VALLEY HOME
4384	LH	EB	LAMBERT	FS	BEACH
4385	LH	EB	LAMBERT	FS	WHITEBOOK
4386	LH	EB	LAMBERT	NS	IDAHO
4387	LH	EB	WHITTIER	NS	RIGSBY
4388	LH	EB	WHITTIER	FS	BEACH
4389	LH	EB	WHITTIER	FS	HACIENDA
4390	LH	EB	WHITTIER	VFS	CORTO
4391	LH	EB	WHITTIER	FS	IDAHO
4392	LH	EB	WHITTIER	NS	MONTE VISTA
4393	LH	EB	WHITTIER	NS	WALNUT
4394	LH	EB	WHITTIER	NS	EUCLID
4395	LH	EB	WHITTIER	FS	CYPRESS
4396	LH	EB	WHITTIER	FS	MAPLE
4397	LH	WB	WHITTIER	FS	HARBOR
4398	LH	WB	WHITTIER	FS	STONEWOOD
4399	LH	WB	WHITTIER	FS	CYPRESS
4400	LH	WB	WHITTIER	FS	EUCLID
4401	LH	WB	WHITTIER	FS	WALNUT
4402	LH	WB	WHITTIER	OPP	MONTE VISTA
4403	LH	WB	WHITTIER	FS	IDAHO
4404	LH	WB	WHITTIER	FS	HACIENDA
4405	LH	WB	WHITTIER	FS	BEACH
4406	LH	WB	WHITTIER	NS	KOOPMANS
4407	LKWD	SB	BLOOMFIELD	FS	DEL AMO
4408	LKWD	SB	BLOOMFIELD	FS	LEMMING
4409	LKWD	WB	CENTRALIA	FS	BLOOMFIELD
4410	LKWD	WB	CENTRALIA	FS	CLARRETA
4411	LKWD	NB	NORWALK	FS	CENTRALIA
4412	LKWD	NB	NORWALK	FS	207TH
4413	LKWD	EB	DEL AMO	FS	PIONEER
4414	LKWD	EB	DEL AMO	FS	VIOLETA
4415	LKWD	EB	DEL AMO	OPP	AVD PAMPLONA
4416	LKWD	EB	DEL AMO	FS	NORWALK
4417	LKWD	EB	DEL AMO	OPP	CLARRETA
4418	LKWD	EB	DEL AMO	FS	BLOOMFIELD

Bus Stop Maintenance

RFP 1-3408

All Stop Locations

Exhibit A

Attachment 2

OCTA_ID	CITY	DIR	STREET_OF_TRAVEL	LOC	CROSS_STREET
4419	LKWD	SB	PIONEER	NS	LOS COYOTES
4420	LM	NB	BEACH	FS	ROSECRANS
4421	LM	NB	BEACH	FS	HAWKS POINTE
4422	LM	NB	BEACH	FS	HILLSBOROUGH
4423	LM	SB	BEACH	FS	HILLSBOROUGH
4424	LM	SB	BEACH	FS	SOMERSET
4425	LM	SB	BEACH	FS	ROSECRANS
4426	LN	NB	ALICIA	FS	CROWN VALLEY
4427	LN	NB	ALICIA	FS	IVY GLENN
4428	LN	NB	ALICIA	NS	NIGUEL
4429	LN	NB	ALICIA	FS	NIGUEL
4430	LN	NB	ALICIA	OPP	SEA BIRD
4431	LN	NB	ALICIA	FS	KITE HILL
4432	LN	NB	ALICIA	OPP	HIGHLANDS
4433	LN	NB	ALICIA	FS	KITE HILL
4434	LN	NB	ALICIA	OPP	AWMA
4435	LN	NB	ALICIA	FS	EL LAZO
4436	LN	NB	ALICIA	FS	FEDERAL LOADING DOCK
4437	LN	NB	ALICIA	FS	AVILA
4438	LN	NB	ALICIA	FS	MARKETPLACE
4439	LN	NB	ALICIA	FS	MARKETPLACE
4440	LN	SB	ALICIA	FS	PACIFIC PARK
4441	LN	SB	ALICIA	OPP	MARKETPLACE
4442	LN	SB	ALICIA	OPP	MARKETPLACE
4443	LN	SB	ALICIA	OPP	AVILA
4444	LN	SB	ALICIA	FS	FEDERAL LOADING DOCK
4445	LN	SB	ALICIA	FS	ALISO CREEK
4446	LN	SB	ALICIA	FS	AWMA
4447	LN	SB	ALICIA	OPP	KITE HILL
4448	LN	SB	ALICIA	FS	HIGHLANDS
4449	LN	SB	ALICIA	FS	CLIPPER
4450	LN	SB	ALICIA	OPP	KITE HILL
4451	LN	SB	ALICIA	FS	SEA BIRD
4452	LN	SB	ALICIA	FS	NIGUEL
4453	LN	SB	ALICIA	FS	PACIFIC ISLAND
4454	LN	EB	AVILA	OPP	HEATHER RIDGE
4455	LN	EB	AVILA	FS	LA PAZ
4456	LN	WB	AVILA	FS	MOULTON
4457	LN	WB	AVILA	FS	LA PAZ
4458	LN	WB	AVILA	FS	HEATHER RIDGE
4459	LN	WB	ALISO CREEK	FS	ALICIA
4460	LN	NB	CABOT	OPP	RAPID FALLS
4461	LN	NB	CROWN VALLEY	FS	CAMINO DEL AVION
4462	LN	NB	CROWN VALLEY	OPP	NATIONAL PARK
4463	LN	NB	CROWN VALLEY	NS	WEST NINE
4464	LN	NB	CROWN VALLEY	FS	WEST NINE

Bus Stop Maintenance

RFP 1-3408

All Stop Locations

Exhibit A

Attachment 2

OCTA_ID	CITY	DIR	STREET_OF_TRAVEL	LOC	CROSS_STREET
4465	LN	NB	CROWN VALLEY	NS	CLUB HOUSE
4466	LN	NB	CROWN VALLEY	FS	PASEO DEL NIGUEL
4467	LN	NB	CROWN VALLEY	NS	HILLHURST
4468	LN	NB	CROWN VALLEY	OPP	ALICIA
4469	LN	NB	CROWN VALLEY	FS	NIGUEL
4470	LN	NB	CROWN VALLEY	OPP	ENT 19751 CROWN VALLEY
4471	LN	NB	CROWN VALLEY	FS	CENTRAL PARK
4472	LN	NB	CROWN VALLEY	NS	LA PLATA
4473	LN	NB	CROWN VALLEY	NS	ADELANTO
4474	LN	NB	CROWN VALLEY	FS	NUEVA VISTA
4475	LN	NB	CROWN VALLEY	FS	GOLDEN LANTERN
4476	LN	NB	CROWN VALLEY	FS	GLENROCK
4477	LN	NB	CROWN VALLEY	FS	GREENFIELD
4478	LN	NB	CROWN VALLEY	FS	CABOT
4479	LN	SB	CROWN VALLEY	NS	FORBES
4480	LN	SB	CROWN VALLEY	FS	CABOT
4481	LN	SB	CROWN VALLEY	OPP	GREENFIELD
4482	LN	SB	CROWN VALLEY	OPP	GLENROCK
4483	LN	SB	CROWN VALLEY	FS	MOULTON
4484	LN	SB	CROWN VALLEY	NS	NUEVA VISTA
4485	LN	SB	CROWN VALLEY	FS	LA PAZ
4486	LN	SB	CROWN VALLEY	FS	LA PLATA
4487	LN	SB	CROWN VALLEY	FS	CENTRAL PARK
4488	LN	SB	CROWN VALLEY	FS	ENT 19751 CROWN VALLEY
4489	LN	SB	CROWN VALLEY	FS	NIGUEL
4490	LN	SB	CROWN VALLEY	FS	ALICIA
4491	LN	SB	CROWN VALLEY	FS	VIA VALLE
4492	LN	SB	CROWN VALLEY	NS	PLAYA BLANCA
4493	LN	SB	CROWN VALLEY	FS	CLUB HOUSE
4494	LN	SB	CROWN VALLEY	FS	LAGUNA WOODS
4495	LN	SB	CROWN VALLEY	OPP	WEST NINE
4496	LN	SB	CROWN VALLEY	NS	NATIONAL PARK
4497	LN	NB	GOLDEN LANTERN	FS	CAMINO DEL AVION
4498	LN	NB	GOLDEN LANTERN	FS	VIA LADERA
4499	LN	NB	GOLDEN LANTERN	FS	OLD RANCH
4500	LN	NB	GOLDEN LANTERN	OPP	BEACON HILL
4501	LN	NB	GOLDEN LANTERN	NS	SAINT CHRISTOPHER
4502	LN	NB	GOLDEN LANTERN	OPP	DUNES
4503	LN	NB	GOLDEN LANTERN	FS	SAINT CHRISTOPHER
4504	LN	NB	GOLDEN LANTERN	OPP	CHAPPAROSA PARK
4505	LN	NB	GOLDEN LANTERN	NS	SWEET MEADOWS
4506	LN	NB	GOLDEN LANTERN	NS	CAMINO LOS PADRES
4507	LN	NB	GOLDEN LANTERN	NS	CRYSTAL CAY
4508	LN	NB	GOLDEN LANTERN	FS	DUCHESS
4509	LN	NB	GOLDEN LANTERN	NS	PASEO ESCUELA
4510	LN	NB	MOULTON	FS	CROWN VALLEY

Bus Stop Maintenance

All Stop Locations

RFP 1-3408

Exhibit A

Attachment 2

OCTA_ID	CITY	DIR	STREET_OF_TRAVEL	LOC	CROSS_STREET
4511	LN	NB	MOULTON	FS	NUEVA VISTA
4512	LN	NB	MOULTON	FS	RANCHO NIGUEL
4513	LN	NB	MOULTON	FS	ENT 28188 VENTANJA
4514	LN	NB	MOULTON	OPP	ALISO CREEK
4515	LN	NB	MOULTON	OPP	AVILA
4516	LN	NB	MOULTON	FS	ALISO NIGUEL
4517	LN	SB	MOULTON	FS	ALISO NIGUEL
4518	LN	SB	MOULTON	FS	AVILA
4519	LN	SB	MOULTON	FS	ALISO CREEK
4520	LN	SB	MOULTON	OPP	ENT 28188 VENTANJA
4521	LN	SB	MOULTON	FS	RANCHO NIGUEL
4522	LN	SB	MOULTON	FS	NUEVA VISTA
4523	LN	SB	GOLDEN LANTERN	FS	CROWN VALLEY
4524	LN	SB	GOLDEN LANTERN	FS	PASEO DE COLINAS
4525	LN	SB	GOLDEN LANTERN	FS	VIA DE ANZA
4526	LN	SB	GOLDEN LANTERN	FS	HIDDEN HILLS
4527	LN	SB	GOLDEN LANTERN	OPP	CRYSTAL CAY
4528	LN	SB	GOLDEN LANTERN	FS	MARINA HILLS
4529	LN	SB	GOLDEN LANTERN	FS	SWEET MEADOWS
4530	LN	SB	GOLDEN LANTERN	FS	CHAPPAROSA PARK
4531	LN	SB	GOLDEN LANTERN	FS	SAINT CHRISTOPHER
4532	LN	SB	GOLDEN LANTERN	FS	DUNES
4533	LN	SB	GOLDEN LANTERN	FS	SARDINA
4534	LN	SB	GOLDEN LANTERN	FS	BEACON HILL
4535	LN	SB	GOLDEN LANTERN	FS	BEAR BRAND
4536	LN	SB	GOLDEN LANTERN	FS	VIA LADERA
4537	LN	NB	LA PAZ	FS	CROWN VALLEY
4538	LN	NB	LA PAZ	NS	KINGS
4539	LN	NB	LA PAZ	FS	RANCHO NIGUEL
4540	LN	NB	LA PAZ	FS	YOSEMITE
4541	LN	NB	LA PAZ	FS	ALISO CREEK
4542	LN	NB	LA PAZ	OPP	ALLEGRA
4543	LN	SB	LA PAZ	FS	AVILA
4544	LN	SB	LA PAZ	NS	ALLEGRA
4545	LN	SB	LA PAZ	FS	ALISO CREEK
4546	LN	SB	LA PAZ	OPP	YOSEMITE
4547	LN	SB	LA PAZ	OPP	RANCHO NIGUEL
4548	LN	SB	LA PAZ	FS	KINGS
4549	LN	NB	NIGUEL	FS	CAMINO DEL AVION
4550	LN	NB	NIGUEL	FS	CHARLES
4551	LN	NB	NIGUEL	NS	RIDGEWAY
4552	LN	NB	NIGUEL	FS	BEACON HILL
4553	LN	NB	NIGUEL	OPP	CLUBHOUSE
4554	LN	NB	NIGUEL	OPP	AUGUSTA
4555	LN	NB	NIGUEL	FS	MARINA HILLS
4556	LN	NB	NIGUEL	FS	CROWN VALLEY

Bus Stop Maintenance

RFP 1-3408

All Stop Locations

Exhibit A

Attachment 2

OCTA_ID	CITY	DIR	STREET_OF_TRAVEL	LOC	CROSS_STREET
4557	LN	SB	NIGUEL	FS	LA HERMOSA
4558	LN	SB	NIGUEL	OPP	MARINA HILLS
4559	LN	SB	NIGUEL	FS	AUGUSTA
4560	LN	SB	NIGUEL	VFS	CLUBHOUSE
4561	LN	SB	NIGUEL	OPP	CHARLES
4562	LN	EB	PACIFIC PARK	FS	ALICIA
4563	LN	EB	PACIFIC PARK	OPP	HEATHER RIDGE
4564	LN	EB	PACIFIC PARK	NS	LA PAZ
4565	LN	EB	PACIFIC PARK	FS	ALISO NIGUEL
4566	LOSAL	EB	BALL	FS	KAYLOR
4567	LOSAL	SB	BLOOMFIELD	FS	BALL
4568	LOSAL	SB	BLOOMFIELD	FS	SAN BONITO
4569	LOSAL	WB	CERRITOS	FS	BLOOMFIELD
4570	LOSAL	WB	CERRITOS	FS	HUMBOLT
4571	LOSAL	WB	CERRITOS	VNS	LOS ALAMITOS
4572	LOSAL	WB	CERRITOS	FS	LOS ALAMITOS
4573	LOSAL	EB	KATELLA	OPP	CIVIC CENTER
4574	LOSAL	EB	KATELLA	VFS	LOS ALAMITOS
4575	LOSAL	EB	KATELLA	NS	REAGAN
4576	LOSAL	EB	KATELLA	NS	MAPLE
4577	LOSAL	EB	KATELLA	FS	BLOOMFIELD
4578	LOSAL	EB	KATELLA	VFS	NOEL
4579	LOSAL	EB	KATELLA	NS	SARATOGA
4580	LOSAL	EB	KATELLA	FS	TICONDEROGA
4581	LOSAL	EB	KATELLA	FS	SIBONEY
4582	LOSAL	EB	KATELLA	FS	WINNERS CIRCLE
4583	LOSAL	EB	KATELLA	OPP	WALKER
4584	LOSAL	WB	KATELLA	OPP	LEXINGTON
4585	LOSAL	WB	KATELLA	FS	PORTAL
4586	LOSAL	WB	KATELLA	FS	BLOOMFIELD
4587	LOSAL	WB	KATELLA	FS	KAYLOR
4588	LOSAL	WB	KATELLA	FS	REAGAN
4589	LOSAL	WB	KATELLA	NS	LOS ALAMITOS
4590	LOSAL	WB	KATELLA	FS	WALNUT
4591	LOSAL	WB	KATELLA	NS	CIVIC CENTER
4592	LOSAL	NB	LOS ALAMITOS	FS	BRADBURY
4593	LOSAL	NB	LOS ALAMITOS	FS	ROSSMOOR
4594	LOSAL	NB	LOS ALAMITOS	FS	ORANGEWOOD
4595	LOSAL	NB	LOS ALAMITOS	NS	FARQUHAR
4596	LOSAL	NB	LOS ALAMITOS	FS	GREEN
4597	LOSAL	NB	LOS ALAMITOS	FS	KATELLA
4598	LOSAL	NB	LOS ALAMITOS	OPP	CATALINA
4599	LOSAL	NB	LOS ALAMITOS	FS	CERRITOS
4600	LOSAL	NB	LOS ALAMITOS	VFS	CERRITOS
4601	LOSAL	SB	LOS ALAMITOS	FS	CERRITOS
4602	LOSAL	SB	LOS ALAMITOS	FS	CATALINA

Bus Stop Maintenance

RFP 1-3408

All Stop Locations

Exhibit A

Attachment 2

OCTA_ID	CITY	DIR	STREET_OF_TRAVEL	LOC	CROSS_STREET
4603	LOSAL	SB	LOS ALAMITOS	FS	KATELLA
4604	LOSAL	SB	LOS ALAMITOS	OPP	FARQUHAR
4605	LOSAL	SB	LOS ALAMITOS	FS	ORANGEWOOD
4606	LOSAL	SB	LOS ALAMITOS	FS	ROSSMOOR
4607	LOSAL	NB	BLOOMFIELD	FS	KATELLA
4608	LP	EB	FRESCA	NS	VALLEY VIEW
4609	LP	EB	LA PALMA	NS	DENNI
4610	LP	EB	LA PALMA	NS	REDFORD
4611	LP	EB	LA PALMA	FS	LOUISE
4612	LP	EB	LA PALMA	FS	MOODY
4613	LP	EB	LA PALMA	FS	ANDRE
4614	LP	EB	LA PALMA	NS	WALKER
4615	LP	EB	LA PALMA	FS	BRAVO
4616	LP	WB	LA PALMA	FS	VALLEY VIEW
4617	LP	WB	LA PALMA	OPP	BRAVO
4618	LP	WB	LA PALMA	FS	WALKER
4619	LP	WB	LA PALMA	NS	INWOOD
4620	LP	WB	LA PALMA	FS	MOODY
4621	LP	WB	LA PALMA	FS	LOUISE
4622	LP	WB	LA PALMA	OPP	REDFORD
4623	LP	EB	ORANGETHORPE	NS	SOMMERSET
4624	LP	EB	ORANGETHORPE	NS	WALKER
4625	LP	WB	ORANGETHORPE	FS	WALKER
4626	LP	WB	ORANGETHORPE	OPP	SOMMERSET
4627	LP	SB	VALLEY VIEW	FS	CENTERPOINTE
4628	LP	SB	VALLEY VIEW	FS	LA PALMA
4629	LP	NB	WALKER	FS	ORANGETHORPE
4630	LW	SB	EL TORO	FS	PASEO DE VALENCIA
4631	LW	SB	EL TORO	FS	AVD SEVILLA
4632	LW	SB	EL TORO	VNS	MOULTON
4633	LW	SB	EL TORO	FS	MOULTON
4634	LW	SB	EL TORO	FS	TOWN CENTRE
4635	LW	SB	EL TORO	FS	CALLE SONORA
4636	LW	SB	EL TORO	OPP	CANYON WREN
4637	LW	SB	EL TORO	FS	CALLE CORTA
4638	LW	SB	EL TORO	OPP	ALISO CREEK
4639	LW	NB	EL TORO	FS	CALLE SONORA
4640	LW	NB	EL TORO	FS	MOULTON
4641	LW	NB	EL TORO	VFS	MOULTON
4642	LW	NB	EL TORO	FS	AVD SEVILLA
4643	LW	WB	LAGUNA HILLS	FS	PASEO DE VALENCIA
4644	LW	NB	MOULTON	NS	CALLE ARAGON
4645	LW	NB	MOULTON	OPP	VIA CAMPO VERDE
4646	LW	NB	MOULTON	FS	EL TORO
4647	LW	SB	MOULTON	FS	SANTA MARIA
4648	LW	SB	MOULTON	OPP	ENT CLUBHOUSE 12

Bus Stop Maintenance

RFP 1-3408

All Stop Locations

Exhibit A

Attachment 2

OCTA_ID	CITY	DIR	STREET_OF_TRAVEL	LOC	CROSS_STREET
4649	LW	SB	MOULTON	FS	EL TORO
4650	LW	SB	MOULTON	FS	VIA CAMPO VERDE
4651	AV	SB	MOULTON	FS	CALLE CORTEZ
4652	AV	SB	MOULTON	FS	VIA IGLESIA
4653	AV	SB	MOULTON	OPP	CALLE ARAGON
4654	LW	EB	PASEO DE VALENCIA	FS	EL TORO
4655	LW	EB	PASEO DE VALENCIA	FS	CALLE DE LA PLATA
4656	LW	EB	PASEO DE VALENCIA	NS	VIA ESTRADA
4657	LW	SB	PASEO DE VALENCIA	NS	AVD SEVILLA
4658	MV	EB	ALICIA	FS	CHARLINDA
4659	MV	EB	ALICIA	NS	MUIRLANDS
4660	MV	EB	ALICIA	FS	ALTHEA
4661	MV	EB	ALICIA	NS	VIA FABRICANTE
4662	MV	EB	ALICIA	FS	JERONIMO
4663	MV	EB	ALICIA	OPP	VIA LINDA
4664	MV	EB	ALICIA	FS	CORONEL
4665	MV	EB	ALICIA	FS	MONTEBELLO
4666	MV	EB	ALICIA	OPP	VIA LEON
4667	MV	EB	ALICIA	FS	TRABUCO
4668	MV	EB	ALICIA	FS	VIA AURORA
4669	MV	EB	ALICIA	FS	MARGUERITE
4670	MV	EB	ALICIA	FS	CYPRESS POINT
4671	MV	EB	ALICIA	FS	CALLE AZORIN
4672	MV	EB	ALICIA	OPP	LANZAROTE
4673	MV	EB	ALICIA	FS	OLYMPIAD
4674	MV	EB	ALICIA	OPP	RUSTIC OAK
4675	MV	WB	ALICIA	FS	RUSTIC OAK
4676	MV	WB	ALICIA	FS	OLYMPIAD
4677	MV	WB	ALICIA	FS	LANZAROTE
4678	MV	WB	ALICIA	FS	CALLE AZORIN
4679	MV	WB	ALICIA	VFS	FINISTERRA
4680	MV	WB	ALICIA	FS	MARGUERITE
4681	MV	WB	ALICIA	FS	VIA AURORA
4682	MV	WB	ALICIA	FS	TRABUCO
4683	MV	WB	ALICIA	FS	VIA LEON
4684	MV	WB	ALICIA	FS	VIA LONGRONO
4685	MV	WB	ALICIA	FS	CORONEL
4686	MV	WB	ALICIA	FS	VIA LINDA
4687	MV	WB	ALICIA	FS	JERONIMO
4688	MV	WB	ALICIA	FS	ALTHEA
4689	MV	WB	ALICIA	NS	MUIRLANDS
4690	MV	WB	ALICIA	NS	CHARLINDA
4691	MV	NB	CABOT	OPP	VISTA VIEJO
4692	MV	SB	CABOT	FS	VISTA VIEJO
4693	MV	NB	CHRISANTA	FS	PRADERA
4694	MV	NB	CROWN VALLEY	OPP	PUERTA REAL

Bus Stop Maintenance

RFP 1-3408

All Stop Locations

Exhibit A

Attachment 2

OCTA_ID	CITY	DIR	STREET_OF_TRAVEL	LOC	CROSS_STREET
4695	MV	NB	CROWN VALLEY	FS	MEDICAL CENTER
4696	MV	NB	CROWN VALLEY	FS	LOS ALTOS
4697	MV	NB	CROWN VALLEY	FS	BELLOGENTE
4698	MV	SB	CROWN VALLEY	NS	BELLOGENTE
4699	MV	SB	CROWN VALLEY	FS	DOCTOR GUEVARA
4700	MV	SB	CROWN VALLEY	FS	PUERTA REAL
4701	MV	EB	JERONIMO	FS	LOS ALISOS
4702	MV	EB	JERONIMO	FS	PETER A HARTMAN
4703	MV	EB	JERONIMO	FS	OBRERO
4704	MV	EB	JERONIMO	OPP	ACERO
4705	MV	EB	JERONIMO	VFS	ALICIA
4706	MV	EB	JERONIMO	FS	CORDILLERA
4707	MV	EB	JERONIMO	FS	MONTILLA
4708	MV	EB	JERONIMO	FS	CARRANZA
4709	MV	EB	JERONIMO	OPP	VALYERMO
4710	MV	EB	JERONIMO	FS	QUINTANA
4711	MV	EB	JERONIMO	FS	PAVION
4712	MV	WB	JERONIMO	FS	MARGUERITE
4713	MV	EB	JERONIMO	FS	OLYMPIAD
4714	MV	WB	JERONIMO	FS	EL CANTADA
4715	MV	WB	JERONIMO	FS	VALYERMO
4716	MV	WB	JERONIMO	OPP	CARRANZA
4717	MV	WB	JERONIMO	FS	MONTILLA
4718	MV	WB	JERONIMO	FS	CORDILLERA
4719	MV	WB	JERONIMO	VFS	ALICIA
4720	MV	WB	JERONIMO	FS	ACERO
4721	MV	WB	JERONIMO	FS	OBRERO
4722	MV	WB	JERONIMO	OPP	PETER A HARTMAN
4723	MV	EB	LA PAZ	FS	CHRISANTA
4724	MV	EB	LA PAZ	FS	MARGUERITE
4725	MV	EB	LA PAZ	FS	COMMERCE CENTER
4726	MV	WB	LA PAZ	FS	VETERANS
4727	MV	WB	LA PAZ	NS	WORLD CUP CENTER
4728	MV	WB	LA PAZ	FS	MARGUERITE
4729	MV	WB	LA PAZ	FS	SPADRA
4730	MV	WB	LA PAZ	FS	CHRISANTA
4731	MV	NB	LOS ALISOS	FS	MUIRLANDS
4732	MV	NB	LOS ALISOS	FS	MUSTANG RUN
4733	MV	SB	LOS ALISOS	FS	SANTA MARGARITA
4734	MV	NB	MARGUERITE	FS	VIA ESCOLAR
4735	MV	NB	MARGUERITE	NS	AVERY
4736	MV	NB	MARGUERITE	NS	ENT 28452 BURLINGTON COAT
4737	MV	NB	MARGUERITE	FS	ENT 28000 SADDLEBACK
4738	MV	NB	MARGUERITE	OPP	SOUTH DECK
4739	MV	NB	MARGUERITE	FS	COLLEGE
4740	MV	NB	MARGUERITE	FS	HILLCREST

Bus Stop Maintenance

RFP 1-3408

All Stop Locations

Exhibit A

Attachment 2

OCTA_ID	CITY	DIR	STREET_OF_TRAVEL	LOC	CROSS_STREET
4741	MV	NB	MARGUERITE	FS	CROWN VALLEY
4742	MV	NB	MARGUERITE	OPP	VENADO
4743	MV	NB	MARGUERITE	FS	CORDOVA CANYON
4744	MV	NB	MARGUERITE	OPP	LA SIERRA
4745	MV	NB	MARGUERITE	FS	FELIPE
4746	MV	NB	MARGUERITE	OPP	MESILLA
4747	MV	NB	MARGUERITE	OPP	VERANO
4748	MV	NB	MARGUERITE	VFS	OSO
4749	MV	NB	MARGUERITE	OPP	VIA ANGELINA
4750	MV	NB	MARGUERITE	NS	PACIFIC
4751	MV	NB	MARGUERITE	OPP	ESTANCIERO
4752	MV	NB	MARGUERITE	NS	VILLAGE CENTER NORTH
4753	MV	NB	MARGUERITE	FS	LA PAZ
4754	MV	NB	MARGUERITE	FS	VIA FLORECER
4755	MV	NB	MARGUERITE	FS	JERONIMO
4756	MV	NB	MARGUERITE	OPP	PUEBLO NUEVO
4757	MV	NB	MARGUERITE	FS	TRABUCO
4758	MV	NB	MARGUERITE	FS	CASTA DEL SOL
4759	MV	NB	MARGUERITE	FS	COSO
4760	MV	NB	MARGUERITE	FS	ALERZAL
4761	MV	NB	MARGUERITE	FS	ALICIA
4762	MV	NB	MARGUERITE	OPP	ANTELA
4763	MV	NB	MARGUERITE	FS	VISTA DEL LAGO
4764	MV	NB	MARGUERITE	OPP	ALARCON
4765	MV	NB	MARGUERITE	FS	OLYMPIAD
4766	MV	NB	MARGUERITE	FS	LA BARCA
4767	MV	NB	MARGUERITE	NS	ENT 21622 VISTA DEL LAGO
4768	MV	SB	MARGUERITE	FS	SANTA MARGARITA
4769	MV	SB	MARGUERITE	OPP	ENT 21622 VISTA DEL LAGO
4770	MV	SB	MARGUERITE	FS	LA BARCA
4771	MV	SB	MARGUERITE	OPP	OLYMPIAD
4772	MV	SB	MARGUERITE	FS	ALARCON
4773	MV	SB	MARGUERITE	FS	VISTA DEL LAGO
4774	MV	SB	MARGUERITE	FS	ANTELA
4775	MV	SB	MARGUERITE	FS	ALICIA
4776	MV	SB	MARGUERITE	OPP	ALERZAL
4777	MV	SB	MARGUERITE	OPP	COSO
4778	MV	SB	MARGUERITE	OPP	CASTA DEL SOL
4779	MV	SB	MARGUERITE	NS	VIA FLORES
4780	MV	SB	MARGUERITE	FS	TRABUCO
4781	MV	SB	MARGUERITE	FS	PUEBLO NUEVO
4782	MV	SB	MARGUERITE	FS	JERONIMO
4783	MV	SB	MARGUERITE	OPP	VIA FLORECER
4784	MV	SB	MARGUERITE	FS	LA PAZ
4785	MV	SB	MARGUERITE	FS	CIVIC CENTER
4786	MV	SB	MARGUERITE	FS	ESTANCIERO

Bus Stop Maintenance

All Stop Locations

RFP 1-3408

Exhibit A

Attachment 2

OCTA_ID	CITY	DIR	STREET_OF_TRAVEL	LOC	CROSS_STREET
4787	MV	SB	MARGUERITE	FS	VIA CASITAS
4788	MV	SB	MARGUERITE	FS	VIA ANGELINA
4789	MV	SB	MARGUERITE	FS	OSO
4790	MV	SB	MARGUERITE	FS	VERANO
4791	MV	SB	MARGUERITE	FS	MESILLA
4792	MV	SB	MARGUERITE	NS	LA MANCHA
4793	MV	SB	MARGUERITE	FS	LA SIERRA
4794	MV	SB	MARGUERITE	OPP	CORDOVA CANYON
4795	MV	SB	MARGUERITE	NS	CROWN VALLEY
4796	MV	SB	MARGUERITE	FS	CROWN VALLEY
4797	MV	SB	MARGUERITE	FS	HILLCREST
4798	MV	SB	MARGUERITE	FS	MEDICAL CENTER
4799	MV	SB	MARGUERITE	FS	SOUTH DECK
4800	MV	SB	MARGUERITE	FS	SHOPS BOULEVARD
4801	MV	SB	MARGUERITE	NS	ENT 28451 AUDI MISSION
4802	MV	SB	MARGUERITE	FS	AVERY
4803	MV	SB	MARGUERITE	OPP	VIA ESCOLAR
4804	MV	EB	MEDICAL CENTER	FS	CROWN VALLEY
4805	MV	EB	MEDICAL CENTER	OPP	ENT MISSION HOSPITAL
4806	MV	WB	MEDICAL CENTER	FS	MARGUERITE
4807	MV	WB	MEDICAL CENTER	FS	ENT MISSION HOSPITAL
4808	MV	SB	MELINDA	FS	SANTA MARGARITA
4809	MV	EB	MUSTANG RUN	FS	LOS ALISOS
4810	MV	EB	MUSTANG RUN	FS	CRUCERO
4811	MV	WB	MUSTANG RUN	OPP	CRUCERO
4812	MV	EB	OSO	FS	COUNTRY CLUB
4813	MV	WB	OSO	FS	MARGUERITE
4814	MV	WB	OSO	OPP	COUNTRY CLUB
4815	MV	SB	PRADERA	FS	ENT LA PAZ
4816	MV	EB	SANTA MARGARITA	FS	LOS ALISOS
4817	MV	EB	SANTA MARGARITA	FS	MARGUERITE
4818	MV	EB	SANTA MARGARITA	OPP	PINECREST
4819	MV	EB	SANTA MARGARITA	OPP	MONTEREY
4820	MV	EB	SANTA MARGARITA	OPP	PROMENADE
4821	RSM	EB	SANTA MARGARITA	FS	MELINDA
4822	MV	WB	SANTA MARGARITA	FS	MELINDA
4823	MV	WB	SANTA MARGARITA	FS	PROMENADE
4824	MV	WB	SANTA MARGARITA	FS	MONTEREY
4825	MV	WB	SANTA MARGARITA	FS	PINECREST
4826	MV	WB	SANTA MARGARITA	FS	MARGUERITE
4827	MV	WB	SANTA MARGARITA	FS	LOS ALISOS
4828	MV	EB	TRABUCO	FS	LOS ALISOS
4829	MV	EB	TRABUCO	FS	ALICIA
4830	MV	EB	TRABUCO	FS	VIA VICTORIA
4831	MV	EB	TRABUCO	FS	CARLOTA
4832	MV	EB	TRABUCO	NS	PUERTA DE LUZ

Bus Stop Maintenance

All Stop Locations

RFP 1-3408

Exhibit A

Attachment 2

OCTA_ID	CITY	DIR	STREET_OF_TRAVEL	LOC	CROSS_STREET
4833	MV	WB	TRABUCO	FS	MARGUERITE
4834	MV	WB	TRABUCO	FS	PUERTA DE LUZ
4835	MV	WB	TRABUCO	OPP	CARLOTA
4836	MV	WB	TRABUCO	FS	VIA VICTORIA
4837	MV	WB	TRABUCO	FS	ALICIA
4838	MV	WB	TRABUCO	FS	LOS ALISOS
4839	MV	NB	VETERANS	FS	LA PAZ
4840	MV	WB	VIA ESCOLAR	FS	CAPISTRANO VALLEY
4841	MV	EB	VIA GRANADOS	OPP	CALLE VALDES
4842	MV	NB	CALLE VALDES	NS	ESPINOZA
4843	MV	NB	ENTRANCE	@	CASTA DEL SOL
4844	MV	NB	CALLE VALDES	OPP	VIA STORNI
4845	MV	NB	CALLE VALDES	NS	CALLE AZORIN
4846	MV	NB	ALAVA	NS	EL GRECO
4847	MV	SB	RIBALTA	OPP	BARBOSA
4848	MV	SB	CALLE AZORIN	FS	CALLE ESPINA
4849	MV	NB	INTERIOR	@	MURRAY COMMUNITY
4850	MV	SB	ENTRANCE	@	LUCKY'S MARKET
4851	MV	EB	COLLEGE	FS	COLLEGE DRIVE WEST
4852	MV	NB	INTERIOR	@	SILVERADO HIGH SCHOOL
4853	NB	EB	16TH	FS	IRVINE
4854	NB	WB	16TH	FS	DOVER
4855	NB	EB	16TH	OPP	SEAGULL
4856	NB	EB	32ND	OPP	LAKE
4857	NB	NB	AVOCADO	FS	ENT NEWPORT BEACH
4858	NB	NB	AVOCADO	FS	SAN MIGUEL
4859	NB	SB	AVOCADO	FS	SAN MIGUEL
4860	NB	SB	AVOCADO	NS	CORPORATE PLAZA
4861	NB	SB	BALBOA	FS	46TH
4862	NB	SB	BALBOA	FS	41ST
4863	NB	SB	BALBOA	NS	38TH
4864	NB	SB	BALBOA	FS	35TH
4865	NB	SB	BALBOA	FS	32ND
4866	NB	SB	BALBOA	FS	28TH
4867	NB	EB	BALBOA	FS	19TH
4868	NB	EB	BALBOA	FS	17TH
4869	NB	EB	BALBOA	FS	15TH
4870	NB	EB	BALBOA	FS	13TH
4871	NB	EB	BALBOA	FS	11TH
4872	NB	EB	BALBOA	FS	8TH
4873	NB	EB	BALBOA	FS	ISLAND
4874	NB	EB	BALBOA	FS	CORONADO
4875	NB	EB	BALBOA	FS	ADAMS
4876	NB	WB	BALBOA	FS	PALM
4877	NB	WB	BALBOA	FS	CORONADO
4878	NB	WB	BALBOA	FS	ISLAND

Bus Stop Maintenance

All Stop Locations

RFP 1-3408

Exhibit A

Attachment 2

OCTA_ID	CITY	DIR	STREET_OF_TRAVEL	LOC	CROSS_STREET
4879	NB	WB	BALBOA	NS	8TH
4880	NB	WB	BALBOA	FS	12TH
4881	NB	WB	BALBOA	OPP	16TH
4882	NB	WB	BALBOA	NS	20TH
4883	NB	NB	BALBOA	FS	23RD
4884	NB	NB	BALBOA	VFS	23RD
4885	NB	NB	BALBOA	NS	28TH
4886	NB	NB	BALBOA	FS	32ND
4887	NB	NB	BALBOA	NS	35TH
4888	NB	NB	BALBOA	NS	38TH
4889	NB	NB	BALBOA	FS	41ST
4890	NB	NB	BALBOA	NS	RIVER
4891	NB	NB	BAYSIDE	FS	JAMBOREE
4892	NB	NB	BAYSIDE	NS	EAST PROMONTORY POINT
4893	NB	NB	BAYSIDE	VFS	EAST PROMONTORY POINT
4894	NB	NB	BAYSIDE	FS	WEST PROMONTORY PT
4895	NB	SB	BAYSIDE	FS	COAST
4896	NB	SB	BAYSIDE	NS	HARBOR ISLAND
4897	NB	SB	BAYSIDE	OPP	EAST PROMONTORY POINT
4898	NB	SB	BAYSIDE	NS	ENT 919 NEWPORT
4899	NB	NB	BIRCH	FS	BRISTOL
4900	NB	NB	BIRCH	NS	QUAIL
4901	NB	NB	BIRCH	FS	DOVE
4902	NB	NB	BIRCH	FS	CORINTHIAN
4903	NB	EB	BIRCH	FS	MACARTHUR
4904	NB	WB	BIRCH	FS	VON KARMAN
4905	NB	WB	BIRCH	NS	MACARTHUR
4906	NB	SB	BIRCH	VFS	MACARTHUR
4907	NB	SB	BIRCH	FS	DOVE
4908	NB	SB	BIRCH	FS	QUAIL
4909	NB	EB	BISON	FS	JAMBOREE
4910	NB	EB	BISON	OPP	ENT 1000 MARINERS
4911	NB	EB	BISON	FS	BELCOURT
4912	NB	WB	BISON	FS	MACARTHUR
4913	NB	WB	BISON	FS	ENT 1000 MARINERS
4914	NB	EB	BONITA CANYON	FS	MACARTHUR
4915	NB	WB	BONITA CANYON	FS	MESA VIEW
4916	NB	WB	BONITA CANYON	NS	MACARTHUR
4917	NB	NB	BRISTOL	FS	JAMBOREE
4918	NB	NB	BRISTOL	FS	SPRUCE
4919	NB	NB	BRISTOL	FS	BIRCH
4920	NB	SB	BRISTOL	FS	BAYVIEW
4921	NB	EB	CAMPUS	FS	MACARTHUR
4922	NB	EB	CAMPUS	FS	MACARTHUR COURT
4923	NB	EB	CAMPUS	OPP	BARDEEN
4924	NB	EB	CAMPUS	FS	TELLER

Bus Stop Maintenance

RFP 1-3408

All Stop Locations

Exhibit A

Attachment 2

OCTA_ID	CITY	DIR	STREET_OF_TRAVEL	LOC	CROSS_STREET
4925	NB	SB	COAST	FS	ORANGE
4926	NB	SB	COAST	FS	PROSPECT
4927	NB	SB	COAST	VFS	PROSPECT
4928	NB	EB	COAST	FS	BALBOA
4929	NB	EB	COAST	NS	BALBOA COVES
4930	NB	EB	COAST	OPP	TUSTIN
4931	NB	EB	COAST	NS	ENT 1931 SEA SCOUT BASE
4932	NB	EB	COAST	FS	ENT 1221 BALBOA BAY CLUB
4933	NB	EB	COAST	FS	BAYSHORE
4934	NB	EB	COAST	FS	BAYSIDE
4935	NB	EB	COAST	FS	PROMONTORY POINT
4936	NB	EB	COAST	FS	JAMBOREE
4937	NB	EB	COAST	NS	IRVINE TERRACE
4938	NB	SB	COAST	FS	AVOCADO
4939	NB	SB	COAST	NS	GOLDENROD
4940	NB	SB	COAST	NS	IRIS
4941	NB	SB	COAST	NS	MARGUERITE
4942	NB	SB	COAST	FS	ORCHID
4943	NB	SB	COAST	NS	POPPY
4944	NB	SB	COAST	FS	SEAWARD
4945	NB	SB	COAST	FS	MORNING CANYON
4946	NB	SB	COAST	FS	CAMEO SHORES
4947	NB	NB	COAST	FS	CAMEO HIGHLANDS
4948	NB	NB	COAST	FS	MORNING CANYON
4949	NB	NB	COAST	FS	SEAWARD
4950	NB	NB	COAST	FS	POPPY
4951	NB	NB	COAST	NS	ORCHID
4952	NB	NB	COAST	NS	MARGUERITE
4953	NB	NB	COAST	NS	IRIS
4954	NB	NB	COAST	NS	GOLDENROD
4955	NB	NB	COAST	NS	AVOCADO
4956	NB	WB	COAST	FS	IRVINE TERRACE
4957	NB	WB	COAST	OPP	PROMONTORY POINT
4958	NB	WB	COAST	FS	BAYSIDE
4959	NB	WB	COAST	FS	DOVER
4960	NB	WB	COAST	OPP	ENT 1221 BALBOA BAY CLUB
4961	NB	WB	COAST	FS	ENT 2200 NEWPORT PACIFIC
4962	NB	WB	COAST	FS	RIVERSIDE
4963	NB	WB	COAST	FS	ENT HOAG HOSPITAL
4964	NB	NB	COAST	FS	SUPERIOR
4965	NB	NB	COAST	NS	PROSPECT
4966	NB	NB	COAST	NS	ORANGE
4967	NB	NB	DOVER	VFS	CASTAWAYS
4968	NB	NB	DOVER	VFS	COAST
4969	NB	SB	DOVER	VFS	WESTCLIFF
4970	NB	SB	DOVER	FS	16TH

Bus Stop Maintenance

All Stop Locations

RFP 1-3408

Exhibit A

Attachment 2

OCTA_ID	CITY	DIR	STREET_OF_TRAVEL	LOC	CROSS_STREET
4971	NB	SB	DOVER	FS	CLIFF
4972	NB	NB	EASTBLUFF	OPP	MAR VISTA
4973	NB	NB	EASTBLUFF	OPP	VISTA DEL ORO
4974	NB	NB	EASTBLUFF	NS	BIXIA
4975	NB	NB	EASTBLUFF	FS	CACAO
4976	NB	SB	EASTBLUFF	FS	JAMBOREE
4977	NB	SB	EASTBLUFF	FS	VISTA DEL ORO
4978	NB	SB	EASTBLUFF	NS	VISTA DEL SOL
4979	NB	SB	EASTBLUFF	FS	VISTA DEL ORO
4980	NB	SB	EASTBLUFF	NS	MAR VISTA
4981	NB	EB	HOSPITAL	FS	SUPERIOR
4982	NB	EB	HOSPITAL	NS	HOAG
4983	NB	EB	HOSPITAL	FS	NEWPORT
4984	NB	EB	HOSPITAL	FS	HOAG
4985	NB	WB	HOSPITAL	FS	NEWPORT
4986	NB	WB	HOSPITAL	NS	PLACENTIA
4987	NB	WB	HOSPITAL	NS	SUPERIOR
4988	NB	NB	IRVINE	FS	16TH
4989	NB	NB	IRVINE	FS	UNIVERSITY
4990	NB	NB	IRVINE	NS	MESA
4991	NB	NB	IRVINE	NS	BRISTOL
4992	NB	NB	JAMBOREE	FS	BAYSIDE
4993	NB	NB	JAMBOREE	NS	BACK BAY
4994	NB	NB	JAMBOREE	FS	ISLAND LAGOON
4995	NB	NB	JAMBOREE	FS	SANTA BARBARA
4996	NB	NB	JAMBOREE	FS	SAN JOAQUIN HILLS
4997	NB	NB	JAMBOREE	FS	FORD
4998	NB	NB	JAMBOREE	FS	BISON
4999	NB	NB	JAMBOREE	FS	CAMELBACK
5000	NB	NB	JAMBOREE	VFS	UNIVERSITY
5001	NB	NB	JAMBOREE	FS	BAYVIEW
5002	NB	NB	JAMBOREE	NS	MACARTHUR
5003	NB	SB	JAMBOREE	FS	BIRCH
5004	NB	SB	JAMBOREE	FS	FAIRCHILD
5005	NB	SB	JAMBOREE	FS	BRISTOL
5006	NB	SB	JAMBOREE	FS	BAYVIEW
5007	NB	SB	JAMBOREE	FS	EASTBLUFF
5008	NB	SB	JAMBOREE	FS	BISON
5009	NB	SB	JAMBOREE	VFS	EASTBLUFF
5010	NB	SB	JAMBOREE	FS	SAN JOAQUIN HILLS
5011	NB	SB	JAMBOREE	FS	SANTA BARBARA
5012	NB	SB	JAMBOREE	NS	HYATT NEWPORTER
5013	NB	SB	JAMBOREE	FS	BACK BAY
5014	NB	SB	JAMBOREE	FS	COAST
5015	NB	NB	MACARTHUR	FS	SAN MIGUEL
5016	NB	NB	MACARTHUR	NS	SAN JOAQUIN HILLS

Bus Stop Maintenance

All Stop Locations

RFP 1-3408

Exhibit A

Attachment 2

OCTA_ID	CITY	DIR	STREET_OF_TRAVEL	LOC	CROSS_STREET
5017	NB	NB	MACARTHUR	FS	BONITA CANYON
5018	NB	NB	MACARTHUR	FS	VILAGGIO
5019	NB	NB	MACARTHUR	VFS	JAMBOREE
5020	NB	NB	MACARTHUR	FS	VON KARMAN
5021	NB	NB	MACARTHUR	OPP	CORINTHIAN
5022	NB	NB	MACARTHUR	NS	BIRCH
5023	NB	SB	MACARTHUR	FS	CAMPUS
5024	NB	SB	MACARTHUR	FS	BIRCH
5025	NB	SB	MACARTHUR	FS	CORINTHIAN
5026	NB	SB	MACARTHUR	FS	NEWPORT
5027	NB	SB	MACARTHUR	VNS	JAMBOREE
5028	NB	SB	MACARTHUR	FS	BISON
5029	NB	SB	MACARTHUR	OPP	VILAGGIO
5030	NB	SB	MACARTHUR	FS	FORD
5031	NB	SB	MACARTHUR	FS	SAN JOAQUIN HILLS
5032	NB	NB	NEWPORT	NS	FINLEY
5033	NB	NB	NEWPORT	NS	HOSPITAL
5034	NB	NB	NEWPORT	FS	OLD NEWPORT
5035	NB	SB	NEWPORT	NS	OLD NEWPORT
5036	NB	SB	NEWPORT	FS	HOSPITAL
5037	NB	SB	NEWPORT	FS	SHORT
5038	NB	SB	NEWPORT	OPP	31ST
5039	NB	SB	NEWPORT	NS	28TH
5040	NB	SB	NEWPORT	NS	23RD
5041	NB	NB	NEWPORT CENTER	FS	FARALLON
5042	NB	EB	NEWPORT CENTER EAST	FS	NEWPORT CENTER
5043	NB	EB	NEWPORT CENTER EAST	FS	ANACAPA
5044	NB	NB	NEWPORT CENTER EAST	FS	SAN MIGUEL
5045	NB	NB	NEWPORT CENTER EAST	FS	SANTA ROSA
5046	NB	WB	NEWPORT CENTER WEST	VNS	SANTA CRUZ
5047	NB	SB	NEWPORT CENTER WEST	FS	SANTA CRUZ
5048	NB	SB	NEWPORT CENTER WEST	VFS	SANTA BARBARA
5049	NB	SB	NEWPORT CENTER	FS	NEWPORT CENTER WEST
5050	NB	NB	NEWPORT CENTER WEST	OPP	NEWPORT CENTER
5051	NB	NB	NEWPORT CENTER WEST	OPP	SANTA BARBARA
5052	NB	EB	NEWPORT CENTER WEST	OPP	SANTA CRUZ
5053	NB	SB	NEWPORT CENTER EAST	OPP	SANTA ROSA
5054	NB	SB	NEWPORT CENTER EAST	OPP	SAN MIGUEL
5055	NB	WB	NEWPORT CENTER EAST	OPP	ANACAPA
5056	NB	EB	OCEAN FRONT	OPP	WASHINGTON
5057	NB	EB	FORD	FS	NEWPORT HILLS EAST
5058	NB	EB	FORD	OPP	MESA VIEW
5059	NB	WB	FORD	OPP	NEWPORT HILLS EAST
5060	NB	WB	FORD	NS	MESA VIEW
5061	NB	NB	PLACENTIA	FS	FLAGSHIP
5062	NB	NB	PLACENTIA	FS	SUPERIOR

Bus Stop Maintenance

All Stop Locations

RFP 1-3408

Exhibit A

Attachment 2

OCTA_ID	CITY	DIR	STREET_OF_TRAVEL	LOC	CROSS_STREET
5063	NB	NB	PLACENTIA	OPP	PRODUCTION
5064	NB	SB	PLACENTIA	FS	PRODUCTION
5065	NB	SB	PLACENTIA	FS	15TH
5066	NB	SB	PLACENTIA	FS	SUPERIOR
5067	NB	EB	SAN JOAQUIN HILLS	FS	JAMBOREE
5068	NB	EB	SAN JOAQUIN HILLS	FS	SANTA ROSA
5069	NB	EB	SAN JOAQUIN HILLS	FS	MACARTHUR
5070	NB	WB	SAN JOAQUIN HILLS	NS	MACARTHUR
5071	NB	WB	SAN JOAQUIN HILLS	FS	BIG CANYON
5072	NB	EB	SAN MIGUEL	FS	NEWPORT CENTER EAST
5073	NB	NB	SAN MIGUEL	NS	PACIFIC VIEW
5074	NB	NB	SAN MIGUEL	FS	YACHT COQUETTE
5075	NB	NB	SAN MIGUEL	FS	YACHT COQUETTE
5076	NB	NB	SAN MIGUEL	FS	SPYGLASS HILL
5077	NB	NB	SAN MIGUEL	FS	PORT RAMSEY
5078	NB	SB	SAN MIGUEL	FS	FORD
5079	NB	SB	SAN MIGUEL	FS	EASTGATE
5080	NB	SB	SAN MIGUEL	OPP	YACHT COQUETTE
5081	NB	SB	SAN MIGUEL	FS	PORT SUTTON
5082	NB	SB	SAN MIGUEL	NS	BAYWOOD
5083	NB	WB	SAN MIGUEL	NS	MACARTHUR
5084	NB	EB	SAN NICOLAS	FS	NEWPORT CENTER EAST
5085	NB	EB	SANTA CRUZ	FS	SAN JOAQUIN HILLS
5086	NB	NB	SANTA ROSA	FS	NEWPORT CENTER
5087	NB	SB	SANTA ROSA	FS	CENTER
5088	NB	NB	SUPERIOR	OPP	TICONDEROGA
5089	NB	SB	SUPERIOR	NS	15TH
5090	NB	NB	SUPERIOR	FS	DANA
5091	NB	NB	SUPERIOR	VNS	DANA
5092	NB	SB	SUPERIOR	FS	TICONDEROGA
5093	NB	EB	UNIVERSITY	FS	JAMBOREE
5094	NB	EB	UNIVERSITY	FS	LA VIDA
5095	NB	WB	UNIVERSITY	NS	BAYPOINTE
5096	NB	NB	VON KARMAN	FS	BIRCH
5097	NB	SB	VON KARMAN	FS	CAMPUS
5098	NB	EB	WESTCLIFF	VFS	IRVINE
5099	NB	EB	WESTCLIFF	OPP	BUCKINGHAM
5100	NB	WB	WESTCLIFF	FS	BUCKINGHAM
5101	NB	WB	WESTCLIFF	FS	RUTLAND
5102	NB	EB	INTERIOR	@	DOCK 1
5103	NB	EB	INTERIOR	@	DOCK 2
5104	NB	SB	INTERIOR	@	DOCK 3
5105	NB	SB	INTERIOR	@	DOCK 4
5106	NB	SB	INTERIOR	@	DOCK 5
5107	NB	SB	INTERIOR	@	DOCK 6
5108	NB	SB	INTERIOR	@	DOCK 7

Bus Stop Maintenance

All Stop Locations

RFP 1-3408

Exhibit A

Attachment 2

OCTA_ID	CITY	DIR	STREET_OF_TRAVEL	LOC	CROSS_STREET
5109	NB	SB	INTERIOR	@	DOCK 8
5110	NB	SB	INTERIOR	@	DOCK 9
5111	ANA	SB	INTERIOR	@	BAY 1
5112	OC	EB	BALL	NS	PERDIDO
5113	OC	EB	BALL	FS	PHOENIX CLUB
5114	OC	WB	BALL	OPP	PHOENIX CLUB
5115	OC	WB	BALL	NS	YARDLEY
5116	OC	SB	BROOKHURST	FS	BROADWAY
5117	OC	SB	BROOKHURST	FS	PALAIS
5118	OC	EB	ORANGETHORPE	OPP	BOISSERANC
5119	OC	EB	ORANGETHORPE	OPP	CYMBAL
5120	OC	WB	ORANGETHORPE	FS	CYMBAL
5121	OC	WB	ORANGETHORPE	NS	BOISSERANC
5122	OC	WB	KATELLA	NS	JEAN
5123	ANA	EB	LA PALMA	OPP	JENIFER
5124	OC	EB	LA PALMA	OPP	FAIRMONT
5125	AV	NB	ALICIA	FS	PACIFIC PARK
5126	AV	NB	ALICIA	FS	MORNING RIDGE
5127	AV	NB	ALICIA	FS	HOLLYOAK
5128	AV	SB	ALICIA	OPP	RAMONA
5129	AV	SB	ALICIA	OPP	HOLLYOAK
5130	AV	SB	ALICIA	OPP	MORNING RIDGE
5131	AV	WB	ALISO CREEK	FS	GLENHURST
5132	AV	NB	ALISO CREEK	OPP	LIBERTY
5133	AV	NB	ALISO CREEK	FS	WOLVERINE
5134	AV	NB	ALISO CREEK	OPP	JOURNEY
5135	AV	NB	ALISO CREEK	FS	PACIFIC PARK
5136	AV	NB	ALISO CREEK	FS	AUTUMNGLEN
5137	AV	NB	ALISO CREEK	FS	SUMMERFIELD
5138	AV	NB	ALISO CREEK	FS	WINDSONG
5139	AV	NB	ALISO CREEK	FS	ALISO VIEJO
5140	AV	NB	ALISO CREEK	FS	ARGONAUT
5141	AV	NB	ALISO CREEK	FS	GLENWOOD
5142	AV	WB	ALISO CREEK	FS	EASTWING
5143	AV	WB	ALISO CREEK	FS	WESTWING
5144	AV	EB	ALISO CREEK	FS	EL TORO
5145	AV	EB	ALISO CREEK	FS	WESTWING
5146	AV	EB	ALISO CREEK	FS	EASTWING
5147	AV	SB	ALISO CREEK	FS	GLENWOOD
5148	AV	SB	ALISO CREEK	FS	COLUMBIA
5149	AV	SB	ALISO CREEK	FS	ALISO VIEJO
5150	AV	SB	ALISO CREEK	FS	WINDSONG
5151	AV	SB	ALISO CREEK	FS	ENTERPRISE
5152	AV	SB	ALISO CREEK	FS	PACIFIC PARK
5153	AV	SB	ALISO CREEK	FS	JOURNEY
5154	AV	SB	ALISO CREEK	FS	ALISO VIEJO

Bus Stop Maintenance

All Stop Locations

RFP 1-3408

Exhibit A

Attachment 2

OCTA_ID	CITY	DIR	STREET_OF_TRAVEL	LOC	CROSS_STREET
5155	AV	SB	ALISO CREEK	FS	LIBERTY
5156	AV	EB	ALISO CREEK	FS	PURSUIT
5157	AV	NB	EL TORO	FS	BELLS VIREO
5158	AV	NB	EL TORO	OPP	CANYON HILLS
5159	LAGH	NB	MOULTON	FS	INDIAN HILL
5160	LAGH	NB	MOULTON	FS	LAGUNA HILLS
5161	LAGH	NB	MOULTON	FS	INDIAN CREEK
5162	AV	SB	MOULTON	FS	GLENWOOD
5163	AV	SB	MOULTON	FS	ALISO VIEJO
5164	AV	SB	MOULTON	OPP	INDIAN HILL
5165	AV	EB	OSO	FS	MAREBLU
5166	AV	WB	OSO	NS	MAREBLU
5167	AV	WB	PACIFIC PARK	NS	ALISO VIEJO PLAZA
5168	AV	WB	PACIFIC PARK	FS	LA PAZ
5169	AV	WB	PACIFIC PARK	FS	HEATHER RIDGE
5170	OC	NB	SANTA ANA	VFS	MESA
5171	OC	NB	SANTA ANA	FS	ORCHARD
5172	OC	SB	SANTA ANA	OPP	ORCHARD
5173	OC	SB	SANTA ANA	NS	MESA
5174	LF	NB	BAKE	OPP	RUE DE FORTUNA
5175	LF	SB	BAKE	OPP	LAKE FOREST
5176	LF	SB	BAKE	FS	RUE DE FORTUNA
5177	LF	SB	LAKE FOREST	FS	BAKE
5178	LF	SB	PALOMA	FS	MONTECITO
5179	LF	WB	PORTOLA	FS	ALTON
5180	OC	EB	EDINGER	FS	HARBOR
5181	OC	EB	EDINGER	FS	BROOKHURST
5182	OC	WB	WARNER	OPP	WARD
5183	OC	WB	KATELLA	FS	GILBERT
5184	OC	WB	KATELLA	@	BERRY
5185	OC	SB	PACIFIC COAST	NS	24TH
5186	OC	SB	PACIFIC COAST	FS	19TH
5187	OC	SB	PACIFIC COAST	NS	12TH
5188	OC	SB	PACIFIC COAST	FS	6TH
5189	OC	EB	WARNER	OPP	PACIFIC
5190	HB	NB	PACIFIC COAST	FS	SEAPOINT
5191	OC	SB	PACIFIC COAST	OPP	SEAPOINT
5192	OC	WB	MAIN	FS	SKY PARK SOUTH
5193	OC	WB	TRABUCO	FS	C
5194	OC	EB	IRVINE	FS	DESERT STORM
5195	OC	SB	AIRPORT	@	ARRIVAL TERMINAL
5196	OC	SB	AIRPORT	@	DEPARTURE TERMINAL
5197	OC	SB	AIRPORT	FS	ENT PARKING LOT B1
5198	OC	NB	COAST	NS	ENT 8681 EL MORRO
5199	OC	SB	EL TORO	FS	AVD DE LA CARLOTA
5200	AV	NB	EL TORO	FS	ALISO CREEK

Bus Stop Maintenance

RFP 1-3408

All Stop Locations

Exhibit A

Attachment 2

OCTA_ID	CITY	DIR	STREET_OF_TRAVEL	LOC	CROSS_STREET
5201	AV	NB	EL TORO	FS	CALLE CORTA
5202	AV	NB	EL TORO	FS	TANAGER
5203	AV	NB	EL TORO	FS	CANYON WREN
5204	LAGH	EB	LAGUNA HILLS	FS	MOULTON
5205	LAGH	EB	LAGUNA HILLS	FS	INDIAN HILL
5206	LAGH	WB	LAGUNA HILLS	FS	INDIAN HILL
5207	LAGH	NB	MOULTON	FS	VIA LOMAS
5208	RSM	NB	ALICIA	OPP	SAN BENITO
5209	RSM	SB	ALICIA	FS	SANTA MARGARITA
5210	RSM	SB	ALICIA	FS	SAN BENITO
5211	RSM	SB	ALICIA	FS	SANTA CLARA
5212	RSM	EB	SANTA MARGARITA	FS	SAN SEBASTIAN
5213	RSM	EB	SANTA MARGARITA	FS	ALICIA
5214	RSM	WB	SANTA MARGARITA	OPP	ALICIA
5215	RSM	WB	SANTA MARGARITA	OPP	SAN SEBASTIAN
5216	CM	SB	BRISTOL	FS	SANTA ANA
5217	OC	SB	BRISTOL	NS	BIRCH
5218	OC	SB	BRISTOL	NS	SPRUCE
5219	OC	WB	CAMPUS	FS	MACARTHUR
5220	OC	NB	COAST	FS	REEF POINT
5221	OC	NB	COAST	FS	LOS TRANCOS
5222	OC	NB	COAST	FS	CRYSTAL HEIGHTS
5223	OC	NB	COAST	FS	NEWPORT COAST
5224	OC	NB	COAST	FS	PELICAN POINT
5225	OC	SB	COAST	FS	PELICAN POINT
5226	OC	SB	COAST	OPP	NEWPORT COAST
5227	OC	SB	COAST	FS	CRYSTAL COVE
5228	OC	SB	COAST	OPP	CRYSTAL HEIGHTS
5229	OC	SB	COAST	FS	REEF POINT
5230	OC	NB	IRVINE	FS	ORCHARD
5231	OC	SB	IRVINE	FS	BRISTOL
5232	OC	SB	IRVINE	FS	MESA
5233	OC	SB	IRVINE	NS	UNIVERSITY
5234	OC	WB	CHAPMAN	FS	ORANGE PARK
5235	OC	EB	CHAPMAN	OPP	ORANGE PARK
5236	OC	WB	FOOTHILL	FS	NEWPORT
5237	OC	WB	FOOTHILL	FS	OLD FOOTHILL
5238	OC	WB	FOOTHILL	NS	HEWES
5239	OC	EB	FOOTHILL	OPP	OLD FOOTHILL
5240	OC	EB	FOOTHILL	OPP	ORANGE KNOLL
5241	OC	NB	HEWES	OPP	VALE
5242	OC	NB	HEWES	FS	WINNWOOD
5243	OC	NB	HEWES	FS	SPRING
5244	OR	SB	HEWES	NS	FAIRHAVEN
5245	OC	SB	HEWES	NS	FAIRWOOD
5246	OC	EB	LA VETA	FS	YORBA

Bus Stop Maintenance

RFP 1-3408

All Stop Locations

Exhibit A

Attachment 2

OCTA_ID	CITY	DIR	STREET_OF_TRAVEL	LOC	CROSS_STREET
5247	OC	WB	LINCOLN	OPP	DELL
5248	OC	WB	LINCOLN	OPP	BATAVIA
5249	OC	EB	YORBA LINDA	OPP	CARTHAGE
5250	OC	WB	YORBA LINDA	FS	CARTHAGE
5251	OC	NB	TUSTIN	FS	17TH
5252	OC	WB	SUNFLOWER	FS	FLOWER
5253	OC	WB	SUNFLOWER	FS	STEVENS
5254	OC	WB	SUNFLOWER	NS	STEVENS
5255	SA	SB	FAIRVIEW	OPP	EDNA
5256	OC	WB	CHAPMAN	FS	NEARING
5257	OC	WB	CHAPMAN	VFS	NEARING
5258	OC	NB	MAGNOLIA	FS	KATELLA
5259	STN	NB	MAGNOLIA	FS	STACIE
5260	OC	SB	MAGNOLIA	NS	SYRACUSE
5261	OC	WB	KATELLA	NS	MAGNOLIA
5262	OC	WB	IRVINE	FS	BROWNING
5263	OC	WB	IRVINE	OPP	DEAN
5264	OC	WB	IRVINE	NS	RED HILL
5265	OC	WB	IRVINE	FS	CHARLOMA
5266	OC	EB	IRVINE	FS	RED HILL
5267	OC	EB	IRVINE	FS	DEAN
5268	OC	NB	NEWPORT	FS	TUSTIN PINES
5269	OC	NB	NEWPORT	FS	LA COLINA
5270	OC	NB	NEWPORT	NS	EL CAMINO
5271	OC	NB	NEWPORT	FS	CASTLEGATE
5272	OC	NB	NEWPORT	FS	LA LOMA
5273	OC	SB	NEWPORT	NS	DODGE
5274	OC	SB	NEWPORT	FS	LA LOMA
5275	OC	SB	NEWPORT	FS	CASTLEGATE
5276	OC	SB	NEWPORT	FS	17TH
5277	OC	SB	NEWPORT	FS	VANDERLIP
5278	OC	EB	17TH	NS	HOWLAND
5279	OC	EB	17TH	OPP	MAUVE
5280	OC	EB	17TH	NS	HOLT
5281	OC	EB	17TH	NS	CARRIAGE
5282	OC	EB	17TH	OPP	HEWES
5283	OC	WB	17TH	NS	GIMBERT
5284	OC	WB	17TH	FS	HEWES
5285	OC	WB	17TH	NS	ESPLANADE
5286	OC	WB	17TH	FS	HOLT
5287	OC	WB	17TH	FS	MAUVE
5288	OC	EB	BOLSA	FS	JACKSON
5289	OC	EB	BOLSA	OPP	JEFFERSON
5290	OC	WB	BOLSA	NS	PURDY
5291	OC	WB	BOLSA	NS	NEWLAND
5292	OC	WB	BOLSA	NS	JEFFERSON

Bus Stop Maintenance

RFP 1-3408

All Stop Locations

Exhibit A

Attachment 2

OCTA_ID	CITY	DIR	STREET_OF_TRAVEL	LOC	CROSS_STREET
5293	OC	WB	BOLSA	NS	JACKSON
5294	WEST	WB	BOLSA	NS	BEACH
5295	OC	EB	MCFADDEN	FS	WILSON
5296	OC	NB	NEWLAND	FS	MADISON
5297	OC	SB	NEWLAND	FS	HAZARD
5298	OC	SB	NEWLAND	FS	MADISON
5299	OC	EB	HAZARD	NS	RIATA
5300	OC	WB	MCFADDEN	FS	VAN BUREN
5301	YL	EB	YORBA LINDA	FS	KELLOGG
5302	OC	WB	ESPERANZA	NS	FAIRLYNN
5303	OC	WB	ESPERANZA	NS	IMPERIAL
5304	OR	NB	CAMBRIDGE	FS	CHARLYNN
5305	OR	NB	CAMBRIDGE	NS	PALMYRA
5306	OR	SB	CAMBRIDGE	FS	PALMYRA
5307	OR	SB	CAMBRIDGE	NS	LA VETA
5308	OR	NB	CANAL	FS	MEATS
5309	OR	NB	CANAL	VFS	MEATS
5310	OR	NB	CANAL	OPP	VISTA DEL PLAYA
5311	OR	NB	CANAL	NS	HEIM
5312	OR	EB	CHAPMAN	FS	LEWIS
5313	OR	EB	CHAPMAN	FS	MANCHESTER
5314	OR	EB	CHAPMAN	FS	THE CITY
5315	OR	EB	CHAPMAN	OPP	STATE COLLEGE
5316	OR	EB	CHAPMAN	FS	FLOWER
5317	OR	EB	CHAPMAN	FS	FELDNER
5318	OR	EB	CHAPMAN	FS	MAIN
5319	OR	EB	CHAPMAN	FS	BATAVIA
5320	OR	EB	CHAPMAN	FS	GRAND
5321	OR	EB	CHAPMAN	FS	SHAFFER
5322	OR	EB	CHAPMAN	FS	HARWOOD
5323	OR	EB	CHAPMAN	FS	CAMBRIDGE
5324	OR	EB	CHAPMAN	FS	WATER
5325	OR	EB	CHAPMAN	NS	LINCOLN
5326	OR	EB	CHAPMAN	FS	TUSTIN
5327	OR	EB	CHAPMAN	FS	YORBA
5328	OR	EB	CHAPMAN	NS	MALENA
5329	OR	EB	CHAPMAN	FS	PROSPECT
5330	OR	EB	CHAPMAN	FS	JAMES
5331	OR	EB	CHAPMAN	FS	ESPLANADE
5332	OR	EB	CHAPMAN	FS	HEWES
5333	OR	EB	CHAPMAN	OPP	RANCHO SANTIAGO
5334	OR	EB	CHAPMAN	FS	SOLANA
5335	OR	EB	CHAPMAN	FS	LOS TIMBRES
5336	OR	EB	CHAPMAN	NS	CANYON VIEW
5337	OR	EB	CHAPMAN	FS	CALLE GRANDE
5338	OR	EB	CHAPMAN	FS	CHANDLER RANCH

Bus Stop Maintenance

RFP 1-3408

All Stop Locations

Exhibit A

Attachment 2

OCTA_ID	CITY	DIR	STREET_OF_TRAVEL	LOC	CROSS_STREET
5339	OR	WB	CHAPMAN	VFS	JAMBOREE
5340	OR	WB	CHAPMAN	OPP	TRAILS END
5341	OR	WB	CHAPMAN	FS	NEWPORT
5342	OR	WB	CHAPMAN	FS	BROADMOOR TRAIL
5343	OR	WB	CHAPMAN	NS	BRAMBLES
5344	OR	WB	CHAPMAN	FS	CLIFFWAY
5345	OR	WB	CHAPMAN	OPP	CANYON VIEW
5346	OR	WB	CHAPMAN	FS	CANNON
5347	OR	WB	CHAPMAN	FS	RANCHO SANTIAGO
5348	OR	WB	CHAPMAN	FS	HEWES
5349	OR	WB	CHAPMAN	FS	ESPLANADE
5350	OR	WB	CHAPMAN	OPP	JAMES
5351	OR	WB	CHAPMAN	NS	PROSPECT
5352	OR	WB	CHAPMAN	NS	MALENA
5353	OR	WB	CHAPMAN	OPP	YORBA
5354	OR	WB	CHAPMAN	FS	WAYFIELD
5355	OR	WB	CHAPMAN	FS	TUSTIN
5356	OR	WB	CHAPMAN	FS	MONTEREY
5357	OR	WB	CHAPMAN	FS	CAMBRIDGE
5358	OR	WB	CHAPMAN	FS	HARWOOD
5359	OR	WB	CHAPMAN	NS	SHAFFER
5360	OR	WB	CHAPMAN	NS	GRAND
5361	OR	WB	CHAPMAN	NS	CITRUS
5362	OR	WB	CHAPMAN	FS	MAIN
5363	OR	WB	CHAPMAN	FS	FELDNER
5364	OR	WB	CHAPMAN	FS	FLOWER
5365	OR	WB	CHAPMAN	NS	STATE COLLEGE
5366	OR	WB	CHAPMAN	FS	THE CITY
5367	OR	WB	CHAPMAN	FS	MANCHESTER
5368	OR	WB	CHAPMAN	FS	LEWIS
5369	OR	WB	CHAPMAN	NS	JETTY
5370	OR	EB	CITY	FS	CITY BLVD EAST
5371	OR	EB	CITY	VFS	CITY BLVD EAST
5372	OR	NB	CITY BLVD EAST	FS	CITY WAY
5373	OR	SB	CITY BLVD NORTH	FS	CITY BLVD WEST
5374	OR	EB	COLLINS	FS	MAIN
5375	OR	EB	COLLINS	NS	BATAVIA
5376	OR	EB	COLLINS	OPP	PARKER
5377	OR	EB	COLLINS	NS	LEMON
5378	OR	EB	COLLINS	OPP	WANDA
5379	OR	EB	COLLINS	FS	MALLARD
5380	OR	WB	COLLINS	NS	LEMON
5381	OR	WB	COLLINS	NS	PARKER
5382	OR	WB	COLLINS	NS	BATAVIA
5383	OR	WB	COLLINS	NS	ENTERPRISE
5384	OR	WB	COLLINS	NS	MORGAN

Bus Stop Maintenance

RFP 1-3408

All Stop Locations

Exhibit A

Attachment 2

OCTA_ID	CITY	DIR	STREET_OF_TRAVEL	LOC	CROSS_STREET
5385	OR	WB	GARDEN GROVE	VFS	THE CITY
5386	OR	WB	GARDEN GROVE	OPP	SIEMON
5387	OR	NB	GLASSELL	FS	ENT HART PARK
5388	OR	NB	GLASSELL	FS	LA VETA
5389	OR	NB	GLASSELL	NS	PALMYRA
5390	OR	NB	GLASSELL	FS	ALMOND
5391	OR	NB	GLASSELL	FS	MAPLE
5392	OR	NB	GLASSELL	NS	PALM
5393	OR	NB	GLASSELL	FS	WALNUT
5394	OR	NB	GLASSELL	NS	MAYFAIR
5395	OR	NB	GLASSELL	FS	JACARANDA
5396	OR	NB	GLASSELL	NS	WILSON
5397	OR	NB	GLASSELL	FS	KATELLA
5398	OR	NB	GLASSELL	FS	TRENTON
5399	OR	NB	GLASSELL	NS	TAFT
5400	OR	NB	GLASSELL	OPP	BLUERIDGE
5401	OR	NB	GLASSELL	FS	MEATS
5402	OR	NB	GLASSELL	FS	BRISTOL
5403	OR	NB	GLASSELL	FS	FLETCHER
5404	OR	NB	GLASSELL	FS	BRENTWOOD
5405	OR	NB	GLASSELL	FS	LINCOLN
5406	OR	NB	GLASSELL	FS	RIVERDALE
5407	OR	SB	GLASSELL	OPP	RIVERDALE
5408	OR	SB	GLASSELL	FS	LINCOLN
5409	OR	SB	GLASSELL	NS	BRENTWOOD
5410	OR	SB	GLASSELL	FS	FLETCHER
5411	OR	SB	GLASSELL	FS	BRISTOL
5412	OR	SB	GLASSELL	FS	MEATS
5413	OR	SB	GLASSELL	FS	BLUERIDGE
5414	OR	SB	GLASSELL	FS	TAFT
5415	OR	SB	GLASSELL	OPP	TRENTON
5416	OR	SB	GLASSELL	FS	KATELLA
5417	OR	SB	GLASSELL	FS	WILSON
5418	OR	SB	GLASSELL	NS	COLLINS
5419	OR	SB	GLASSELL	NS	MAYFAIR
5420	OR	SB	GLASSELL	FS	WALNUT
5421	OR	SB	GLASSELL	NS	PALM
5422	OR	SB	GLASSELL	NS	MAPLE
5423	OR	SB	GLASSELL	FS	ALMOND
5424	OR	SB	GLASSELL	FS	PALMYRA
5425	OR	SB	GLASSELL	FS	LA VETA
5426	OR	SB	GLASSELL	NS	ENT 660 PARK ORLEANS
5427	OR	NB	HEWES	NS	PHILLIPS
5428	OR	NB	HEWES	FS	VIA EL MODENA
5429	OR	NB	HEWES	NS	CHAPMAN
5430	OR	NB	HEWES	NS	PEARL

Bus Stop Maintenance

RFP 1-3408

All Stop Locations

Exhibit A

Attachment 2

OCTA_ID	CITY	DIR	STREET_OF_TRAVEL	LOC	CROSS_STREET
5431	OR	NB	HEWES	FS	SILVERLEAF
5432	OR	SB	HEWES	OPP	SILVERLEAF
5433	OR	SB	HEWES	NS	SPRING
5434	OR	SB	HEWES	NS	CHAPMAN
5435	OR	SB	HEWES	FS	MARMON
5436	OR	SB	HEWES	OPP	PHILLIPS
5437	OR	SB	HEWES	OPP	WINNWOOD
5438	OR	SB	JAMBOREE	FS	CHAPMAN
5439	OR	EB	KATELLA	FS	STRUCK
5440	OR	EB	KATELLA	FS	MAIN
5441	OR	EB	KATELLA	FS	BATAVIA
5442	OR	EB	KATELLA	OPP	MANZANITA
5443	OR	EB	KATELLA	FS	GLASELL
5444	OR	EB	KATELLA	FS	SHAFFER
5445	OR	EB	KATELLA	FS	CAMBRIDGE
5446	OR	EB	KATELLA	NS	CALIFORNIA
5447	OR	EB	KATELLA	FS	TUSTIN
5448	OR	WB	KATELLA	FS	TUSTIN
5449	OR	WB	KATELLA	OPP	CALIFORNIA
5450	OR	WB	KATELLA	NS	CAMBRIDGE
5451	OR	WB	KATELLA	FS	SHAFFER
5452	OR	WB	KATELLA	FS	GLASELL
5453	OR	WB	KATELLA	VFS	GLASELL
5454	OR	WB	KATELLA	FS	MANZANITA
5455	OR	WB	KATELLA	FS	BATAVIA
5456	OR	WB	KATELLA	FS	MAIN
5457	OR	WB	KATELLA	OPP	STRUCK
5458	OR	EB	LA VETA	FS	FLOWER
5459	OR	EB	LA VETA	NS	MAIN
5460	OR	EB	LA VETA	FS	PEPPER
5461	OR	EB	LA VETA	NS	PARKER
5462	OR	EB	LA VETA	FS	LA VETA PARK
5463	OR	EB	LA VETA	OPP	LEMON
5464	OR	EB	LA VETA	FS	GLASELL
5465	OR	EB	LA VETA	FS	SHAFFER
5466	OR	EB	LA VETA	NS	LA VETA FRONTAGE
5467	OR	EB	LA VETA	OPP	MALENA
5468	OR	WB	LA VETA	FS	LAURINDA
5469	OR	WB	LA VETA	FS	YORBA
5470	OR	WB	LA VETA	NS	SHAFFER
5471	OR	WB	LA VETA	NS	TUSTIN
5472	OR	WB	LA VETA	NS	OLIVE
5473	OR	WB	LA VETA	FS	LEMON
5474	OR	WB	LA VETA	FS	PARKER
5475	OR	WB	LA VETA	NS	PEPPER
5476	OR	WB	LA VETA	FS	MAIN

Bus Stop Maintenance

RFP 1-3408

All Stop Locations

Exhibit A

Attachment 2

OCTA_ID	CITY	DIR	STREET_OF_TRAVEL	LOC	CROSS_STREET
5477	OR	WB	LA VETA	FS	FLOWER
5478	OR	SB	LEMON	NS	CHAPMAN
5479	OR	NB	LEWIS	FS	GARDEN GROVE
5480	OR	NB	LEWIS	FS	CHAPMAN
5481	OR	NB	LEWIS	FS	CITY PKWY WEST
5482	OR	NB	LEWIS	FS	METROPOLITAN
5483	OR	SB	LEWIS	OPP	COMPTON
5484	OR	EB	LINCOLN	FS	BATAVIA
5485	OR	EB	LINCOLN	NS	BERKELEY
5486	OR	EB	LINCOLN	FS	ENT 300 MOBILE RITZ
5487	OR	EB	LINCOLN	FS	GLASSELL
5488	OR	EB	LINCOLN	FS	ORANGE-OLIVE
5489	OR	EB	LINCOLN	FS	ANCHOR
5490	OR	EB	LINCOLN	FS	CANAL
5491	OR	WB	LINCOLN	FS	TUSTIN
5492	OR	WB	LINCOLN	NS	OCEANVIEW
5493	OR	WB	LINCOLN	NS	ORANGE-OLIVE
5494	OR	WB	LINCOLN	NS	COTTONWOOD
5495	OR	WB	LINCOLN	FS	GLASSELL
5496	OR	WB	LINCOLN	NS	ENT 315 GEORGIAN
5497	OR	NB	MAIN	NS	TOWN & COUNTRY
5498	OR	NB	MAIN	NS	LA VETA
5499	OR	NB	MAIN	FS	LA VETA
5500	OR	NB	MAIN	FS	STEWART
5501	OR	NB	MAIN	FS	PALMYRA
5502	OR	NB	MAIN	NS	ALMOND
5503	OR	NB	MAIN	FS	CHAPMAN
5504	OR	NB	MAIN	NS	BIRCH
5505	OR	NB	MAIN	FS	WALNUT
5506	OR	NB	MAIN	NS	ALVAREZ
5507	OR	NB	MAIN	NS	SHELLY
5508	OR	NB	MAIN	FS	COLLINS
5509	OR	NB	MAIN	FS	STRUCK
5510	OR	NB	MAIN	FS	KATELLA
5511	OR	NB	MAIN	FS	TRENTON
5512	OR	SB	MAIN	FS	TAFT
5513	OR	SB	MAIN	FS	YALE
5514	OR	SB	MAIN	OPP	TRENTON
5515	OR	SB	MAIN	FS	KATELLA
5516	OR	SB	MAIN	NS	STRUCK
5517	OR	SB	MAIN	NS	COLLINS
5518	OR	SB	MAIN	OPP	BARKLEY
5519	OR	SB	MAIN	OPP	ALVAREZ
5520	OR	SB	MAIN	FS	ORANGEWOOD
5521	OR	SB	MAIN	OPP	BIRCH
5522	OR	SB	MAIN	FS	CHAPMAN

Bus Stop Maintenance

RFP 1-3408

All Stop Locations

Exhibit A

Attachment 2

OCTA_ID	CITY	DIR	STREET_OF_TRAVEL	LOC	CROSS_STREET
5523	OR	SB	MAIN	FS	ALMOND
5524	OR	SB	MAIN	FS	PALMYRA
5525	OR	SB	MAIN	FS	CULVER
5526	OR	SB	MAIN	FS	LA VETA
5527	OR	SB	MANCHESTER	FS	CHAPMAN
5528	OR	EB	MEATS	FS	GLASSELL
5529	OR	EB	MEATS	FS	ORANGE-OLIVE
5530	OR	EB	MEATS	FS	CLEVELAND
5531	OR	EB	MEATS	NS	CAMBRIDGE
5532	OR	EB	MEATS	NS	PARK
5533	OR	EB	MEATS	FS	BRECKENRIDGE
5534	OR	WB	MEATS	FS	SANTIAGO
5535	OR	WB	MEATS	FS	DIAMOND
5536	OR	WB	MEATS	FS	TUSTIN
5537	OR	WB	MEATS	FS	CANAL
5538	OR	WB	MEATS	OPP	CAMBRIDGE
5539	OR	WB	MEATS	FS	HARWOOD
5540	OR	WB	MEATS	FS	ORANGE-OLIVE
5541	OR	SB	MEMORY	FS	TOWN & COUNTRY
5542	OR	EB	METROPOLITAN	FS	LEWIS
5543	OR	EB	METROPOLITAN	FS	ENT 4000 AMERISOURCE
5544	OR	EB	METROPOLITAN	OPP	CITY PKWY SOUTH
5545	OR	EB	METROPOLITAN	NS	THE CITY
5546	OR	WB	METROPOLITAN	FS	THE CITY
5547	OR	WB	METROPOLITAN	NS	CITY PKWY SOUTH
5548	OR	WB	METROPOLITAN	OPP	ENT 4000 AMERISOURCE
5549	OR	WB	METROPOLITAN	NS	LEWIS
5550	OR	NB	NEWPORT	FS	CHAPMAN
5551	OR	NB	NEWPORT	FS	CAMPUS
5552	OR	EB	PALMYRA	OPP	GARDNER
5553	OR	WB	PALMYRA	FS	TUSTIN
5554	OR	WB	PALMYRA	OPP	CALIFORNIA
5555	OR	NB	PARKER	OPP	TOWN & COUNTRY
5556	OR	SB	PARKER	FS	TOWN & COUNTRY
5557	OR	NB	PROSPECT	NS	RUTH
5558	OR	NB	PROSPECT	NS	PALMYRA
5559	OR	NB	PROSPECT	FS	WALNUT
5560	OR	NB	PROSPECT	FS	BOND
5561	OR	SB	PROSPECT	FS	BOND
5562	OR	SB	PROSPECT	NS	WALNUT
5563	OR	SB	PROSPECT	NS	ALMOND
5564	OR	SB	PROSPECT	NS	PALMYRA
5565	OR	SB	PROSPECT	NS	LA VETA
5566	OR	NB	RANCHO SANTIAGO	FS	CHAPMAN
5567	OR	NB	SANTIAGO	FS	TAFT
5568	OR	SB	SANTIAGO	FS	MEATS

Bus Stop Maintenance

RFP 1-3408

All Stop Locations

Exhibit A

Attachment 2

OCTA_ID	CITY	DIR	STREET_OF_TRAVEL	LOC	CROSS_STREET
5569	OR	SB	SANTIAGO	FS	GROVE
5570	OR	SB	SANTIAGO	FS	TAFT
5571	VP	SB	SANTIAGO	NS	ARDEN VILLA
5572	OR	EB	SANTIAGO CANYON	OPP	HIGHBROOK
5573	OR	EB	SANTIAGO CANYON	OPP	HILLGATE
5574	OR	NB	STATE COLLEGE	FS	CHAPMAN
5575	OR	NB	STATE COLLEGE	FS	RAMPART
5576	OR	NB	STATE COLLEGE	OPP	BAKERY
5577	OR	SB	STATE COLLEGE	FS	ANAHEIM
5578	OR	SB	STATE COLLEGE	NS	CHAPMAN
5579	OR	EB	TAFT	FS	MAIN
5580	OR	EB	TAFT	VFS	MAIN
5581	OR	EB	TAFT	FS	BATAVIA
5582	OR	EB	TAFT	FS	CASE
5583	OR	EB	TAFT	FS	O'DONNELL
5584	OR	EB	TAFT	FS	GLASSELL
5585	OR	EB	TAFT	FS	SHAFFER
5586	OR	EB	TAFT	NS	CAMBRIDGE
5587	OR	EB	TAFT	FS	MAPLEWOOD
5588	OR	EB	TAFT	OPP	GREENGROVE
5589	OR	WB	TAFT	FS	TUSTIN
5590	OR	WB	TAFT	FS	GREENGROVE
5591	OR	WB	TAFT	FS	LINDENHOLZ
5592	OR	WB	TAFT	FS	CAMBRIDGE
5593	OR	WB	TAFT	NS	SHAFFER
5594	OR	WB	TAFT	NS	GLASSELL
5595	OR	WB	TAFT	NS	SAINT THOMAS
5596	OR	WB	TAFT	NS	CASE
5597	OR	WB	TAFT	FS	BATAVIA
5598	OR	WB	TAFT	NS	MAIN
5599	OR	NB	THE CITY	FS	MEMORY
5600	OR	NB	THE CITY	OPP	PARK CENTRAL
5601	OR	NB	THE CITY	FS	JUSTICE CENTER
5602	OR	NB	THE CITY	FS	DAWN
5603	OR	NB	THE CITY	FS	CHAPMAN
5604	OR	NB	THE CITY	OPP	ORANGE CENTER
5605	OR	SB	THE CITY	NS	ORANGE CENTER
5606	OR	SB	THE CITY	FS	CHAPMAN
5607	OR	SB	THE CITY	OPP	MEDICAL CENTER
5608	OR	SB	THE CITY	FS	CITY
5609	OR	SB	THE CITY	VFS	CITY
5610	OR	SB	THE CITY	FS	SHOPPERTAINMENT
5611	OR	SB	THE CITY	FS	PARK CENTRAL
5612	OR	EB	TOWN & COUNTRY	FS	LAWSON
5613	OR	NB	TUSTIN	FS	FAIRHAVEN
5614	OR	NB	TUSTIN	NS	SEBA

Bus Stop Maintenance

RFP 1-3408

All Stop Locations

Exhibit A

Attachment 2

OCTA_ID	CITY	DIR	STREET_OF_TRAVEL	LOC	CROSS_STREET
5615	OR	NB	TUSTIN	NS	LA VETA
5616	OR	NB	TUSTIN	FS	PALMYRA
5617	OR	NB	TUSTIN	FS	CHAPMAN
5618	OR	NB	TUSTIN	FS	PALM
5619	OR	NB	TUSTIN	FS	WALNUT
5620	OR	NB	TUSTIN	NS	MAYFAIR
5621	OR	NB	TUSTIN	FS	COLLINS
5622	OR	NB	TUSTIN	NS	ADAMS
5623	OR	NB	TUSTIN	FS	KATELLA
5624	OR	NB	TUSTIN	FS	VANOWEN
5625	OR	NB	TUSTIN	NS	TAFT
5626	OR	NB	TUSTIN	VNS	GROVE
5627	OR	NB	TUSTIN	FS	MEATS
5628	OR	NB	TUSTIN	OPP	EAST VILLAGE WAY
5629	OR	NB	TUSTIN	FS	HEIM
5630	OR	NB	TUSTIN	VNS	NOHL RANCH
5631	OR	NB	TUSTIN	FS	NOHL RANCH
5632	OR	SB	TUSTIN	FS	SUNVIEW
5633	OR	SB	TUSTIN	FS	BIXBY
5634	OR	SB	TUSTIN	FS	LINCOLN
5635	OR	SB	TUSTIN	VFS	LINCOLN
5636	OR	SB	TUSTIN	FS	HEIM
5637	OR	SB	TUSTIN	NS	EAST VILLAGE WAY
5638	OR	SB	TUSTIN	NS	EAST VILLAGE WAY
5639	OR	SB	TUSTIN	NS	EAST VILLAGE WAY
5640	OR	SB	TUSTIN	FS	EAST VILLAGE WAY
5641	OR	SB	TUSTIN	FS	EAST VILLAGE WAY
5642	OR	SB	TUSTIN	FS	MEATS
5643	OR	SB	TUSTIN	OPP	GROVE
5644	OR	SB	TUSTIN	FS	BRIARDALE
5645	OR	SB	TUSTIN	FS	TAFT
5646	OR	SB	TUSTIN	FS	CHESTNUT
5647	OR	SB	TUSTIN	FS	KATELLA
5648	OR	SB	TUSTIN	NS	QUINCY
5649	OR	SB	TUSTIN	FS	COLLINS
5650	OR	SB	TUSTIN	FS	MAYFAIR
5651	OR	SB	TUSTIN	NS	WALNUT
5652	OR	SB	TUSTIN	FS	PALM
5653	OR	SB	TUSTIN	FS	CHAPMAN
5654	OR	SB	TUSTIN	FS	PALMYRA
5655	OR	SB	TUSTIN	FS	ROCK CREEK
5656	OR	SB	TUSTIN	NS	FAIRHAVEN
5657	OR	EB	WALNUT	NS	SWIDLER
5658	OR	EB	WALNUT	FS	ESPLANADE
5659	OR	EB	WALNUT	OPP	EARLHAM
5660	OR	WB	WALNUT	FS	EARLHAM

Bus Stop Maintenance
All Stop Locations

RFP 1-3408
Exhibit A
Attachment 2

OCTA_ID	CITY	DIR	STREET_OF_TRAVEL	LOC	CROSS_STREET
5661	OR	WB	WALNUT	FS	ESPLANADE
5662	OR	WB	WALNUT	FS	GRAVIER
5663	OR	NB	WANDA	FS	VILLA PARK
5664	OR	SB	WANDA	FS	KATELLA
5665	OR	SB	WANDA	FS	HOOVER
5666	OR	SB	WANDA	FS	MONROE
5667	OR	SB	OTC	@	DOCK 2
5668	OR	EB	CAMPUS	VFS	NEWPORT
5669	OR	EB	CITY PKWY EAST	NS	THE CITY
5670	OR	EB	CITY PKWY EAST	FS	CITY BLVD EAST
5671	OR	EB	CITY PKWY WEST	VNS	THE CITY BLVD
5672	OR	WB	CITY PKWY WEST	VFS	CITY BLVD
5673	PLAC	NB	BRADFORD	FS	CHAPMAN
5674	PLAC	NB	BRADFORD	OPP	ORCHID
5675	PLAC	NB	BRADFORD	NS	MADISON
5676	PLAC	NB	BRADFORD	FS	DOVERFIELD
5677	PLAC	NB	BRADFORD	NS	YORBA LINDA
5678	PLAC	SB	BRADFORD	OPP	CARLSON
5679	PLAC	SB	BRADFORD	VNS	RUDY
5680	PLAC	SB	BRADFORD	FS	ORANGE GROVE
5681	PLAC	SB	BRADFORD	FS	ORCHID
5682	PLAC	EB	CHAPMAN	FS	PLACENTIA
5683	PLAC	EB	CHAPMAN	OPP	MELODY
5684	PLAC	EB	CHAPMAN	NS	MELROSE
5685	PLAC	EB	CHAPMAN	FS	BRADFORD
5686	PLAC	EB	CHAPMAN	NS	ANGELINA
5687	PLAC	EB	CHAPMAN	NS	KRAEMER
5688	PLAC	EB	CHAPMAN	FS	MISSION
5689	PLAC	EB	CHAPMAN	FS	CENTRAL
5690	PLAC	EB	CHAPMAN	NS	SAN ANSELMO
5691	PLAC	WB	CHAPMAN	FS	BRADFORD
5692	PLAC	WB	CHAPMAN	NS	WALNUT
5693	PLAC	WB	CHAPMAN	FS	MELODY
5694	PLAC	WB	CHAPMAN	NS	PLACENTIA
5695	PLAC	WB	CHAPMAN	FS	ORANGETHORPE
5696	PLAC	WB	CHAPMAN	OPP	SAN ANSELMO
5697	PLAC	WB	CHAPMAN	FS	CENTRAL
5698	PLAC	WB	CHAPMAN	NS	MISSION
5699	PLAC	WB	CHAPMAN	VFS	ALL AMERICA
5700	PLAC	WB	CHAPMAN	FS	KRAEMER
5701	PLAC	WB	CHAPMAN	FS	ANGELINA
5702	PLAC	NB	KRAEMER	FS	YORBA LINDA
5703	PLAC	NB	KRAEMER	FS	HUDSON
5704	PLAC	NB	KRAEMER	FS	BASTANCHURY
5705	PLAC	NB	KRAEMER	FS	PATRICIAN
5706	PLAC	NB	KRAEMER	FS	GOLDEN

Bus Stop Maintenance

RFP 1-3408

All Stop Locations

Exhibit A

Attachment 2

OCTA_ID	CITY	DIR	STREET_OF_TRAVEL	LOC	CROSS_STREET
5707	PLAC	NB	KRAEMER	FS	CHAPMAN
5708	PLAC	NB	KRAEMER	FS	ALTA VISTA
5709	PLAC	NB	KRAEMER	FS	MADISON
5710	PLAC	NB	KRAEMER	FS	FAIRWAY
5711	PLAC	NB	KRAEMER	NS	MORSE
5712	PLAC	SB	KRAEMER	OPP	GOLDEN
5713	PLAC	SB	KRAEMER	OPP	BAGNALL
5714	PLAC	SB	KRAEMER	NS	SANTA ROSA
5715	PLAC	SB	KRAEMER	FS	BORROMEO
5716	PLAC	SB	KRAEMER	FS	BASTANCHURY
5717	PLAC	SB	KRAEMER	FS	LIVINGSTON
5718	PLAC	SB	KRAEMER	NS	YORBA LINDA
5719	PLAC	SB	KRAEMER	FS	YORBA LINDA
5720	PLAC	SB	KRAEMER	FS	SHEFFIELD
5721	PLAC	SB	KRAEMER	FS	NEWCASTLE
5722	PLAC	SB	KRAEMER	FS	MADISON
5723	PLAC	SB	KRAEMER	FS	ALTA VISTA
5724	PLAC	SB	KRAEMER	FS	CONNECTICUT
5725	PLAC	SB	KRAEMER	FS	CHAPMAN
5726	PLAC	EB	LA JOLLA	FS	MOISI
5727	PLAC	EB	LA JOLLA	OPP	LAWRENCE
5728	PLAC	EB	LA JOLLA	NS	CYPRESS
5729	PLAC	WB	LA JOLLA	FS	CYPRESS
5730	PLAC	WB	LA JOLLA	OPP	WALLGREEN
5731	PLAC	NB	LINDA VISTA	FS	ROSE
5732	PLAC	NB	MELROSE	FS	LA JOLLA
5733	PLAC	SB	MELROSE	FS	ORANGETHORPE
5734	PLAC	SB	MELROSE	NS	LA JOLLA
5735	PLAC	EB	ORANGETHORPE	FS	OHIO
5736	PLAC	EB	ORANGETHORPE	FS	MELROSE
5737	PLAC	EB	ORANGETHORPE	VFS	MELROSE
5738	PLAC	EB	ORANGETHORPE	OPP	COMMUNITY
5739	PLAC	EB	ORANGETHORPE	FS	TUSTIN
5740	PLAC	EB	ORANGETHORPE	FS	JEFFERSON
5741	PLAC	EB	ORANGETHORPE	FS	VAN BUREN
5742	PLAC	EB	ORANGETHORPE	FS	RICHFIELD
5743	PLAC	WB	ORANGETHORPE	FS	LAKEVIEW
5744	PLAC	WB	ORANGETHORPE	FS	RICHFIELD
5745	PLAC	WB	ORANGETHORPE	FS	VAN BUREN
5746	PLAC	WB	ORANGETHORPE	FS	JEFFERSON
5747	PLAC	WB	ORANGETHORPE	NS	ROSE
5748	PLAC	WB	ORANGETHORPE	NS	TRAUB
5749	PLAC	WB	ORANGETHORPE	FS	CHAPMAN
5750	PLAC	WB	ORANGETHORPE	VNS	MELROSE
5751	PLAC	WB	ORANGETHORPE	NS	MELROSE
5752	PLAC	WB	ORANGETHORPE	OPP	IOWA

Bus Stop Maintenance

RFP 1-3408

All Stop Locations

Exhibit A

Attachment 2

OCTA_ID	CITY	DIR	STREET_OF_TRAVEL	LOC	CROSS_STREET
5753	PLAC	NB	PLACENTIA	FS	PRIMROSE
5754	PLAC	NB	PLACENTIA	FS	RUBY
5755	PLAC	NB	PLACENTIA	OPP	VIA BURTON
5756	PLAC	NB	PLACENTIA	FS	CHAPMAN
5757	PLAC	NB	PLACENTIA	NS	HARMONY
5758	PLAC	NB	ROSE	FS	ORANGETHORPE
5759	PLAC	NB	ROSE	FS	ALTA VISTA
5760	PLAC	NB	ROSE	NS	BUENA VISTA
5761	PLAC	NB	ROSE	FS	PALM
5762	PLAC	SB	ROSE	VFS	YORBA LINDA
5763	PLAC	SB	ROSE	FS	LINDA VISTA
5764	PLAC	SB	ROSE	FS	PALM
5765	PLAC	SB	ROSE	OPP	BUENA VISTA
5766	PLAC	SB	ROSE	FS	ALTA VISTA
5767	PLAC	SB	ROSE	NS	ORANGETHORPE
5768	PLAC	NB	VALENCIA	FS	YORBA LINDA
5769	PLAC	NB	VALENCIA	FS	SHADY
5770	PLAC	NB	VALENCIA	FS	HOLMES
5771	PLAC	NB	VALENCIA	FS	BASTANCHURY
5772	PLAC	NB	VALENCIA	OPP	SOMERSET
5773	PLAC	NB	VALENCIA	FS	LEMKE
5774	PLAC	NB	VALENCIA	FS	GOLDEN
5775	PLAC	SB	VALENCIA	FS	SIX NATIONS
5776	PLAC	SB	VALENCIA	FS	GOLDEN
5777	PLAC	SB	VALENCIA	FS	HAIBER
5778	PLAC	SB	VALENCIA	FS	SOMERSET
5779	PLAC	SB	VALENCIA	FS	BASTANCHURY
5780	PLAC	SB	VALENCIA	OPP	HOLMES
5781	PLAC	SB	VALENCIA	OPP	LAWN
5782	PLAC	EB	YORBA LINDA	FS	BRADFORD
5783	PLAC	EB	YORBA LINDA	FS	KRAEMER
5784	PLAC	EB	YORBA LINDA	FS	PALM
5785	PLAC	EB	YORBA LINDA	OPP	BROOKHAVEN
5786	PLAC	EB	YORBA LINDA	FS	CALLE DEL CORONADO
5787	PLAC	EB	YORBA LINDA	FS	VALENCIA
5788	PLAC	EB	YORBA LINDA	OPP	MCCORMACK
5789	PLAC	EB	YORBA LINDA	FS	LINDA VISTA
5790	PLAC	EB	YORBA LINDA	FS	ROSE
5791	PLAC	WB	YORBA LINDA	FS	LINDA VISTA
5792	PLAC	WB	YORBA LINDA	NS	MCCORMACK
5793	PLAC	WB	YORBA LINDA	FS	VALENCIA
5794	PLAC	WB	YORBA LINDA	FS	BROOKHAVEN
5795	PLAC	WB	YORBA LINDA	OPP	PALM
5796	RS	EB	MAGNOLIA	FS	MCKINLEY
5797	RS	EB	MAGNOLIA	@	12890 MAGNOLIA AVE
5798	RS	EB	MAGNOLIA	NS	LINCOLN

Bus Stop Maintenance

RFP 1-3408

All Stop Locations

Exhibit A

Attachment 2

OCTA_ID	CITY	DIR	STREET_OF_TRAVEL	LOC	CROSS_STREET
5799	RS	EB	MAGNOLIA	NS	BUCHANAN
5800	RS	EB	MAGNOLIA	FS	PIERCE
5801	RS	EB	MAGNOLIA	FS	FILLMORE
5802	RS	EB	MAGNOLIA	FS	GOLDEN
5803	RS	EB	MAGNOLIA	FS	PARK SIERRA
5804	RS	EB	MAGNOLIA	FS	POLK
5805	RS	EB	MAGNOLIA	FS	BANBURY
5806	RS	EB	MAGNOLIA	FS	ENT TYLER MALL
5807	RS	EB	MAGNOLIA	NS	HUGHES
5808	RS	EB	MAGNOLIA	NS	HARRISON
5809	RS	EB	MAGNOLIA	NS	MUIR
5810	RS	EB	MAGNOLIA	OPP	ROOSEVELT
5811	RS	EB	MAGNOLIA	NS	VAN BUREN
5812	RS	WB	MAGNOLIA	FS	VAN BUREN
5813	RS	WB	MAGNOLIA	FS	ROOSEVELT
5814	RS	WB	MAGNOLIA	FS	HARRISON
5815	RS	WB	MAGNOLIA	FS	HARRISON
5816	RS	WB	MAGNOLIA	NS	TYLER
5817	RS	WB	MAGNOLIA	FS	BANBURY
5818	RS	WB	MAGNOLIA	NS	POLK
5819	RS	WB	MAGNOLIA	FS	PARK SIERRA
5820	RS	WB	MAGNOLIA	NS	LA SIERRA
5821	RS	WB	MAGNOLIA	NS	GOLDEN
5822	RS	WB	MAGNOLIA	FS	PIERCE
5823	RS	WB	MAGNOLIA	FS	BUCHANAN
5824	RS	WB	MAGNOLIA	OPP	LINCOLN
5825	RS	WB	MAGNOLIA	OPP	12890 MAGNOLIA AVE
5826	RS	NB	MCKINLEY	FS	MAGNOLIA
5827	RS	NB	VAN BUREN	@	NEW YORK PLAZA
5828	RS	SB	VAN BUREN	FS	PRIMROSE
5829	RS	SB	INTERIOR	@	BOARDING DOCK
5830	RSM	EB	ALAS DE PAZ	FS	ANTONIO
5831	OC	NB	ANTONIO	FS	OSO
5832	OC	NB	ANTONIO	FS	MEANDERING TRAIL
5833	RSM	NB	ANTONIO	OPP	TIJERAS CREEK
5834	RSM	NB	ANTONIO	FS	LA VENTANA
5835	RSM	NB	ANTONIO	FS	AVD DE LAS BANDERAS
5836	RSM	NB	ANTONIO	FS	ADELANTE
5837	RSM	NB	ANTONIO	FS	VALEROSO
5838	RSM	NB	ANTONIO	FS	AVD EMPRESA
5839	RSM	NB	ANTONIO	FS	BIENVENIDOS
5840	RSM	NB	ANTONIO	FS	COTO DE CAZA
5841	RSM	NB	ANTONIO	FS	VIA HONESTO
5842	RSM	NB	ANTONIO	VNS	ALAS DE PAZ
5843	RSM	SB	ANTONIO	FS	ALAS DE PAZ
5844	RSM	SB	ANTONIO	FS	VIA ZAPADOR

Bus Stop Maintenance

RFP 1-3408

All Stop Locations

Exhibit A

Attachment 2

OCTA_ID	CITY	DIR	STREET_OF_TRAVEL	LOC	CROSS_STREET
5845	RSM	SB	ANTONIO	FS	VIA HONESTO
5846	RSM	SB	ANTONIO	FS	LA PROMESA
5847	RSM	SB	ANTONIO	FS	BIENVENIDOS
5848	RSM	SB	ANTONIO	FS	AVD EMPRESA
5849	RSM	SB	ANTONIO	FS	VALEROSO
5850	RSM	SB	ANTONIO	FS	ADELANTE
5851	RSM	SB	ANTONIO	FS	AVD DE LAS BANDERAS
5852	RSM	SB	ANTONIO	FS	VIA VERDE
5853	RSM	SB	ANTONIO	NS	TIJERAS CREEK
5854	RSM	NB	ARROYO VISTA	FS	AVD DE LAS BANDERAS
5855	RSM	NB	ARROYO VISTA	FS	ADELANTE
5856	RSM	NB	ARROYO VISTA	FS	VALEROSO
5857	RSM	SB	ARROYO VISTA	FS	AVD EMPRESA
5858	RSM	SB	ARROYO VISTA	OPP	VALEROSO
5859	RSM	SB	ARROYO VISTA	OPP	ADELANTE
5860	RSM	SB	AVD DE LAS BANDERAS	FS	COMERCIO
5861	RSM	EB	AVD DE LAS BANDERAS	FS	ARROYO VISTA
5862	RSM	WB	AVD DE LAS BANDERAS	FS	ANTONIO
5863	RSM	NB	AVD EMPRESA	FS	ESPERANZA
5864	RSM	NB	AVD EMPRESA	FS	AVD DE LAS BANDERAS
5865	RSM	NB	AVD EMPRESA	FS	COMERCIO
5866	RSM	NB	AVD EMPRESA	FS	AVENTURA
5867	RSM	SB	AVD EMPRESA	FS	SANTA MARGARITA
5868	RSM	SB	AVD EMPRESA	FS	AVENTURA
5869	RSM	SB	AVD EMPRESA	FS	COMERCIO
5870	RSM	SB	AVD EMPRESA	FS	AVD DE LAS BANDERAS
5871	RSM	EB	AVENTURA	OPP	CALLE CORTA
5872	RSM	WB	AVENTURA	FS	AVD EMPRESA
5873	RSM	EB	COMERCIO	FS	AVD EMPRESA
5874	RSM	NB	CALLE CORTA	FS	AVENTURA
5875	RSM	SB	CALLE CORTA	FS	SANTA MARGARITA
5876	RSM	NB	PLANO TRABUCO	NS	LAS AMIGAS
5877	RSM	SB	PLANO TRABUCO	FS	SANTA MARGARITA
5878	RSM	SB	PLANO TRABUCO	NS	ALAS DE PAZ
5879	RSM	EB	SANTA MARGARITA	FS	AVD EMPRESA
5880	RSM	EB	SANTA MARGARITA	FS	AVD DE LAS FLORES
5881	RSM	EB	SANTA MARGARITA	FS	BUENA SUERTE
5882	RSM	EB	SANTA MARGARITA	FS	ALMA ALDEA
5883	RSM	EB	SANTA MARGARITA	FS	AVD DE LOS FUNADORES
5884	RSM	EB	SANTA MARGARITA	FS	ANTONIO
5885	RSM	WB	SANTA MARGARITA	FS	ANTONIO
5886	RSM	WB	SANTA MARGARITA	FS	AVD DE LOS FUNADORES
5887	RSM	WB	SANTA MARGARITA	FS	ALMA ALDEA
5888	RSM	WB	SANTA MARGARITA	FS	BUENA SUERTE
5889	RSM	WB	SANTA MARGARITA	FS	AVD DE LAS FLORES
5890	RSM	WB	SANTA MARGARITA	FS	AVD EMPRESA

Bus Stop Maintenance

RFP 1-3408

All Stop Locations

Exhibit A

Attachment 2

OCTA_ID	CITY	DIR	STREET_OF_TRAVEL	LOC	CROSS_STREET
5891	SA	EB	WESTMINSTER	FS	EUCLID
5892	SA	EB	WESTMINSTER	OPP	ROSITA
5893	SA	EB	WESTMINSTER	FS	NEWHOPE
5894	SA	EB	WESTMINSTER	OPP	WEST
5895	SA	EB	WESTMINSTER	FS	HARBOR
5896	SA	EB	WESTMINSTER	OPP	LAUREL
5897	SA	EB	WESTMINSTER	NS	FAIRVIEW
5898	SA	EB	17TH	FS	KING
5899	SA	EB	17TH	OPP	ALONA
5900	SA	EB	17TH	FS	COLLEGE
5901	SA	EB	17TH	FS	ENT SANTA ANA COLLEGE
5902	SA	EB	17TH	FS	BRISTOL
5903	SA	EB	17TH	NS	BAKER
5904	SA	EB	17TH	NS	FREEMAN
5905	SA	EB	17TH	NS	FLOWER
5906	SA	EB	17TH	NS	ROSS
5907	SA	EB	17TH	FS	BROADWAY
5908	SA	EB	17TH	FS	MAIN
5909	SA	EB	17TH	FS	SPURGEON
5910	SA	EB	17TH	OPP	SANTIAGO
5911	SA	EB	17TH	NS	LINCOLN
5912	SA	EB	17TH	VNS	GRAND
5913	SA	EB	17TH	FS	GRAND
5914	SA	EB	17TH	NS	LINWOOD
5915	SA	EB	17TH	FS	CONCORD
5916	SA	EB	17TH	NS	CABRILLO PARK
5917	SA	EB	17TH	FS	WILLIAMS
5918	SA	EB	17TH	NS	TUSTIN
5919	SA	WB	17TH	FS	TUSTIN
5920	SA	WB	17TH	OPP	WILLIAMS
5921	SA	WB	17TH	FS	SHERRY
5922	SA	WB	17TH	OPP	CONCORD
5923	SA	WB	17TH	FS	LINWOOD
5924	SA	WB	17TH	FS	GRAND
5925	SA	WB	17TH	NS	LINCOLN
5926	SA	WB	17TH	NS	SANTIAGO
5927	SA	WB	17TH	OPP	PENN
5928	SA	WB	17TH	NS	MAIN
5929	SA	WB	17TH	NS	BROADWAY
5930	SA	WB	17TH	NS	ROSS
5931	SA	WB	17TH	NS	FLOWER
5932	SA	WB	17TH	OPP	FREEMAN
5933	SA	WB	17TH	FS	BAKER
5934	SA	WB	17TH	FS	BRISTOL
5935	SA	WB	17TH	FS	BRISTOL MARKET PLACE
5936	SA	WB	17TH	FS	COLLEGE

Bus Stop Maintenance

RFP 1-3408

All Stop Locations

Exhibit A

Attachment 2

OCTA_ID	CITY	DIR	STREET_OF_TRAVEL	LOC	CROSS_STREET
5937	SA	WB	17TH	FS	ALONA
5938	SA	WB	17TH	FS	ENGLISH
5939	SA	WB	WESTMINSTER	FS	FAIRVIEW
5940	SA	WB	WESTMINSTER	NS	NANCY
5941	SA	EB	18TH	FS	MAIN
5942	SA	EB	1ST	FS	COOPER
5943	SA	EB	1ST	FS	EUCLID
5944	SA	EB	1ST	NS	ANDRES
5945	SA	EB	1ST	FS	NEWHOPE
5946	SA	EB	1ST	VFS	SHANNON
5947	SA	EB	1ST	FS	HARBOR
5948	SA	EB	1ST	NS	JACKSON
5949	SA	EB	1ST	VNS	FAIRVIEW
5950	SA	EB	1ST	FS	FAIRVIEW
5951	SA	EB	1ST	FS	SULLIVAN
5952	SA	EB	1ST	FS	CENTER
5953	SA	EB	1ST	NS	DAISY
5954	SA	EB	1ST	NS	RAITT
5955	SA	EB	1ST	OPP	WESTERN
5956	SA	EB	1ST	FS	PACIFIC
5957	SA	EB	1ST	FS	BRISTOL
5958	SA	EB	1ST	FS	BAKER
5959	SA	EB	1ST	FS	SHELTON
5960	SA	EB	1ST	NS	BOOTH
5961	SA	EB	1ST	FS	FLOWER
5962	SA	EB	1ST	OPP	ROSS
5963	SA	EB	1ST	NS	BROADWAY
5964	SA	EB	1ST	FS	MAIN
5965	SA	EB	1ST	NS	MAPLE
5966	SA	EB	1ST	NS	HICKORY
5967	SA	EB	1ST	NS	CEDAR
5968	SA	EB	1ST	FS	GRAND
5969	SA	EB	1ST	NS	LYON
5970	SA	EB	1ST	OPP	CABRILLO PARK
5971	SA	EB	1ST	OPP	GOLDEN CIRCLE
5972	SA	WB	1ST	FS	GOLDEN CIRCLE
5973	SA	WB	1ST	NS	CABRILLO PARK
5974	SA	WB	1ST	FS	LYON
5975	SA	WB	1ST	FS	GRAND
5976	SA	WB	1ST	FS	STANDARD
5977	SA	WB	1ST	OPP	HALLADAY
5978	SA	WB	1ST	FS	LACY
5979	SA	WB	1ST	OPP	OAK
5980	SA	WB	1ST	FS	DOWNTOWN PLAZA
5981	SA	WB	1ST	FS	MAIN
5982	SA	WB	1ST	FS	BROADWAY

Bus Stop Maintenance

All Stop Locations

RFP 1-3408

Exhibit A

Attachment 2

OCTA_ID	CITY	DIR	STREET_OF_TRAVEL	LOC	CROSS_STREET
5983	SA	WB	1ST	FS	ROSS
5984	SA	WB	1ST	FS	FLOWER
5985	SA	WB	1ST	FS	SHELTON
5986	SA	WB	1ST	FS	BAKER
5987	SA	WB	1ST	FS	BRISTOL
5988	SA	WB	1ST	FS	PACIFIC
5989	SA	WB	1ST	NS	WESTERN
5990	SA	WB	1ST	FS	RAITT
5991	SA	WB	1ST	NS	TOWNSEND
5992	SA	WB	1ST	OPP	CENTER
5993	SA	WB	1ST	FS	SULLIVAN
5994	SA	WB	1ST	FS	FAIRVIEW
5995	SA	WB	1ST	VFS	FAIRVIEW
5996	SA	WB	1ST	NS	JACKSON
5997	SA	WB	1ST	FS	HARBOR
5998	SA	WB	1ST	OPP	SHANNON
5999	SA	WB	1ST	NS	NEWHOPE
6000	SA	WB	1ST	OPP	ANDRES
6001	SA	WB	1ST	FS	EUCLID
6002	SA	WB	1ST	FS	COOPER
6003	SA	EB	4TH	FS	FRENCH
6004	SA	EB	4TH	NS	LACY
6005	SA	EB	4TH	NS	SANTA FE
6006	SA	WB	4TH	FS	EASTWOOD
6007	SA	WB	4TH	FS	POINSETTIA
6008	SA	WB	4TH	NS	LACY
6009	SA	WB	4TH	FS	MINTER
6010	SA	EB	5TH	NS	FIGUEROA
6011	SA	EB	5TH	FS	JACKSON
6012	SA	EB	5TH	FS	MELISSA COMMON
6013	SA	EB	5TH	FS	FAIRVIEW
6014	SA	EB	5TH	FS	NANTUCKET
6015	SA	EB	5TH	OPP	SUNSET
6016	SA	EB	5TH	FS	RAITT
6017	SA	EB	5TH	FS	PACIFIC
6018	SA	EB	5TH	NS	BRISTOL
6019	SA	EB	5TH	NS	SYCAMORE
6020	SA	EB	5TH	OPP	SPURGEON
6021	SA	WB	5TH	FS	BRISTOL
6022	SA	WB	5TH	NS	PACIFIC
6023	SA	WB	5TH	FS	RAITT
6024	SA	WB	5TH	FS	SUNSET
6025	SA	WB	5TH	OPP	NANTUCKET
6026	SA	WB	5TH	FS	FAIRVIEW
6027	SA	WB	5TH	OPP	MELISSA COMMON
6028	SA	WB	5TH	NS	JACKSON

Bus Stop Maintenance

RFP 1-3408

All Stop Locations

Exhibit A

Attachment 2

OCTA_ID	CITY	DIR	STREET_OF_TRAVEL	LOC	CROSS_STREET
6029	SA	EB	ALTON	FS	MAIN
6030	SA	EB	ALTON	FS	MAPLE
6031	SA	EB	ALTON	NS	HALLADAY
6032	SA	WB	ALTON	FS	HALLADAY
6033	SA	WB	ALTON	FS	OAK
6034	SA	WB	ALTON	NS	MAIN
6035	SA	NB	BRISTOL	FS	SUNFLOWER
6036	SA	NB	BRISTOL	FS	CALLENS COMMON
6037	SA	NB	BRISTOL	FS	MACARTHUR
6038	SA	NB	BRISTOL	NS	ALTON
6039	SA	NB	BRISTOL	FS	SEGERSTROM
6040	SA	NB	BRISTOL	FS	HEMLOCK
6041	SA	NB	BRISTOL	FS	CENTRAL
6042	SA	NB	BRISTOL	NS	WARNER
6043	SA	NB	BRISTOL	FS	SAINT GERTRUDE
6044	SA	NB	BRISTOL	FS	GLENWOOD
6045	SA	NB	BRISTOL	FS	SAINT ANDREW
6046	SA	NB	BRISTOL	FS	EDINGER
6047	SA	NB	BRISTOL	FS	WILSHIRE
6048	SA	NB	BRISTOL	FS	MCFADDEN
6049	SA	NB	BRISTOL	FS	RICHLAND
6050	SA	NB	BRISTOL	FS	BISHOP
6051	SA	NB	BRISTOL	NS	CHESTNUT
6052	SA	NB	BRISTOL	NS	1ST
6053	SA	NB	BRISTOL	FS	SANTA ANA
6054	SA	NB	BRISTOL	NS	CIVIC CENTER
6055	SA	NB	BRISTOL	OPP	10TH
6056	SA	NB	BRISTOL	NS	WASHINGTON
6057	SA	NB	BRISTOL	FS	17TH
6058	SA	NB	BRISTOL	OPP	21ST
6059	SA	NB	BRISTOL	FS	SANTA CLARA
6060	SA	NB	BRISTOL	NS	PARK
6061	SA	NB	BRISTOL	FS	MEMORY
6062	SA	NB	BRISTOL	OPP	RIVERGLEN
6063	SA	SB	BRISTOL	NS	HESPERIAN
6064	SA	SB	BRISTOL	FS	RIVERGLEN
6065	SA	SB	BRISTOL	FS	PARK
6066	SA	SB	BRISTOL	VNS	SANTA CLARA
6067	SA	SB	BRISTOL	FS	21ST
6068	SA	SB	BRISTOL	FS	17TH
6069	SA	SB	BRISTOL	FS	WASHINGTON
6070	SA	SB	BRISTOL	FS	10TH
6071	SA	SB	BRISTOL	FS	CIVIC CENTER
6072	SA	SB	BRISTOL	FS	SANTA ANA
6073	SA	SB	BRISTOL	NS	WALNUT
6074	SA	SB	BRISTOL	FS	MYRTLE

Bus Stop Maintenance

RFP 1-3408

All Stop Locations

Exhibit A

Attachment 2

OCTA_ID	CITY	DIR	STREET_OF_TRAVEL	LOC	CROSS_STREET
6075	SA	SB	BRISTOL	FS	WILLITS
6076	SA	SB	BRISTOL	FS	TOLLIVER
6077	SA	SB	BRISTOL	FS	MCFADDEN
6078	SA	SB	BRISTOL	FS	WILSHIRE
6079	SA	SB	BRISTOL	FS	EDINGER
6080	SA	SB	BRISTOL	FS	SAINT ANDREW
6081	SA	SB	BRISTOL	OPP	CAMDEN
6082	SA	SB	BRISTOL	VNS	WARNER
6083	SA	SB	BRISTOL	FS	WARNER
6084	SA	SB	BRISTOL	FS	CENTRAL
6085	SA	SB	BRISTOL	OPP	HEMLOCK
6086	SA	SB	BRISTOL	FS	SEGERSTROM
6087	SA	SB	BRISTOL	FS	GARRY
6088	SA	SB	BRISTOL	FS	ALTON
6089	SA	SB	BRISTOL	FS	MACARTHUR
6090	SA	SB	BRISTOL	NS	CALLENS COMMON
6091	SA	SB	BRISTOL	NS	SUNFLOWER
6092	SA	NB	BROADWAY	NS	SANTA ANA
6093	SA	NB	BROADWAY	FS	CIVIC CENTER
6094	SA	NB	BROADWAY	NS	10TH
6095	SA	NB	BROADWAY	NS	WASHINGTON
6096	SA	NB	BROADWAY	FS	15TH
6097	SA	SB	BROADWAY	VFS	17TH
6098	SA	SB	BROADWAY	NS	WASHINGTON
6099	SA	SB	BROADWAY	FS	10TH
6100	SA	SB	BROADWAY	FS	CIVIC CENTER
6101	SA	SB	CAMBRIDGE	NS	FAIRHAVEN
6102	SA	EB	CARNEGIE	FS	PULLMAN
6103	SA	EB	CARNEGIE	FS	DAIMLER
6104	SA	WB	CARNEGIE	FS	RED HILL
6105	SA	WB	CARNEGIE	FS	ENT 1911 CARNEGIE
6106	SA	WB	CARNEGIE	NS	PULLMAN
6107	SA	NB	CENTER	FS	EDINGER
6108	SA	NB	CENTER	FS	WILSHIRE
6109	SA	NB	CENTER	NS	MCFADDEN
6110	SA	SB	CENTER	FS	MCFADDEN
6111	SA	SB	CENTER	FS	WILSHIRE
6112	SA	EB	CHESTNUT	FS	MAIN
6113	SA	EB	CHESTNUT	FS	ORANGE
6114	SA	EB	CHESTNUT	FS	OAK
6115	SA	EB	CHESTNUT	FS	HALLADAY
6116	SA	EB	CHESTNUT	FS	GRAND
6117	SA	EB	CHESTNUT	VFS	GRAND
6118	SA	WB	CHESTNUT	VNS	GRAND
6119	SA	WB	CHESTNUT	FS	STANDARD
6120	SA	WB	CHESTNUT	NS	HICKORY

Bus Stop Maintenance

RFP 1-3408

All Stop Locations

Exhibit A

Attachment 2

OCTA_ID	CITY	DIR	STREET_OF_TRAVEL	LOC	CROSS_STREET
6121	SA	WB	CHESTNUT	FS	MAPLE
6122	SA	WB	CHESTNUT	NS	MAIN
6123	SA	EB	CIVIC CENTER	NS	WESTERN
6124	SA	EB	CIVIC CENTER	FS	PACIFIC
6125	SA	EB	CIVIC CENTER	FS	BRISTOL
6126	SA	EB	CIVIC CENTER	FS	BAKER
6127	SA	EB	CIVIC CENTER	OPP	FREEMAN
6128	SA	EB	CIVIC CENTER	OPP	PARTON
6129	SA	EB	CIVIC CENTER	FS	ROSS
6130	SA	EB	CIVIC CENTER	FS	BROADWAY
6131	SA	WB	CIVIC CENTER	FS	BIRCH
6132	SA	WB	CIVIC CENTER	NS	VAN NESS
6133	SA	WB	CIVIC CENTER	FS	PARTON
6134	SA	WB	CIVIC CENTER	FS	FLOWER
6135	SA	WB	CIVIC CENTER	FS	FREEMAN
6136	SA	WB	CIVIC CENTER	FS	BAKER
6137	SA	WB	CIVIC CENTER	FS	BRISTOL
6138	SA	WB	CIVIC CENTER	FS	PACIFIC
6139	SA	WB	CIVIC CENTER	OPP	WESTERN
6140	SA	SB	COLLEGE	FS	17TH
6141	SA	EB	CUBBON	NS	MAIN
6142	SA	WB	CUBBON	FS	CYPRESS
6143	SA	NB	CYPRESS	FS	MCFADDEN
6144	SA	SB	CYPRESS	VNS	MCFADDEN
6145	SA	EB	SEGERSTROM	FS	CRODDY
6146	SA	EB	SEGERSTROM	FS	HARBOR
6147	SA	EB	SEGERSTROM	FS	YALE
6148	SA	EB	SEGERSTROM	FS	SUSAN
6149	SA	EB	SEGERSTROM	FS	FAIRVIEW
6150	SA	EB	SEGERSTROM	FS	GREENVILLE
6151	SA	EB	SEGERSTROM	FS	TOWNSEND
6152	SA	EB	SEGERSTROM	FS	RAITT
6153	SA	EB	SEGERSTROM	FS	DOUGLAS
6154	SA	EB	SEGERSTROM	NS	BEAR
6155	SA	EB	SEGERSTROM	FS	SPRUCE
6156	SA	EB	SEGERSTROM	FS	BRISTOL
6157	SA	EB	SEGERSTROM	OPP	SHELTON
6158	SA	EB	SEGERSTROM	NS	FLOWER
6159	SA	EB	DYER	NS	BRADFORD
6160	SA	EB	DYER	NS	SYCAMORE
6161	SA	EB	DYER	FS	MAIN
6162	SA	EB	DYER	OPP	ORANGE
6163	SA	EB	DYER	FS	OAK
6164	SA	EB	DYER	FS	HALLADAY
6165	SA	EB	DYER	NS	TECHCENTER
6166	SA	EB	DYER	OPP	HOTEL TERRACE

Bus Stop Maintenance

RFP 1-3408

All Stop Locations

Exhibit A

Attachment 2

OCTA_ID	CITY	DIR	STREET_OF_TRAVEL	LOC	CROSS_STREET
6167	SA	EB	DYER	NS	PULLMAN
6168	SA	WB	DYER	FS	RED HILL
6169	SA	WB	DYER	NS	PULLMAN
6170	SA	WB	DYER	NS	HOTEL TERRACE
6171	SA	WB	DYER	FS	TECHCENTER
6172	SA	WB	DYER	FS	HALLADAY
6173	SA	WB	DYER	OPP	OAK
6174	SA	WB	DYER	FS	ORANGE
6175	SA	WB	DYER	FS	MAIN
6176	SA	WB	DYER	FS	SYCAMORE
6177	SA	WB	DYER	OPP	BRADFORD
6178	SA	WB	SEGERSTROM	FS	OLIVE
6179	SA	WB	SEGERSTROM	FS	SHELTON
6180	SA	WB	SEGERSTROM	NS	BRISTOL
6181	SA	WB	SEGERSTROM	FS	SPRUCE
6182	SA	WB	SEGERSTROM	OPP	BEAR
6183	SA	WB	SEGERSTROM	FS	DOUGLAS
6184	SA	WB	SEGERSTROM	FS	RAITT
6185	SA	WB	SEGERSTROM	FS	TOWNSEND
6186	SA	WB	SEGERSTROM	NS	GREENVILLE
6187	SA	WB	SEGERSTROM	NS	FAIRVIEW
6188	SA	WB	SEGERSTROM	FS	SUSAN
6189	SA	WB	SEGERSTROM	FS	YALE
6190	SA	WB	SEGERSTROM	NS	HARBOR
6191	SA	WB	SEGERSTROM	FS	CRODDY
6192	SA	EB	EDINGER	OPP	MOHAWK
6193	SA	EB	EDINGER	FS	FAIRVIEW
6194	SA	EB	EDINGER	OPP	SULLIVAN
6195	SA	EB	EDINGER	FS	GREENVILLE
6196	SA	EB	EDINGER	FS	CENTER
6197	SA	EB	EDINGER	NS	RAITT
6198	SA	EB	EDINGER	NS	PACIFIC
6199	SA	EB	EDINGER	FS	BRISTOL
6200	SA	EB	EDINGER	FS	PARK
6201	SA	EB	EDINGER	NS	FLOWER
6202	SA	EB	EDINGER	FS	VAN NESS
6203	SA	EB	EDINGER	FS	BROADWAY
6204	SA	EB	EDINGER	NS	MAIN
6205	SA	EB	EDINGER	FS	MAPLE
6206	SA	EB	EDINGER	FS	KILSON
6207	SA	EB	EDINGER	NS	CEDAR
6208	SA	EB	EDINGER	FS	STANDARD
6209	SA	EB	EDINGER	FS	GRAND
6210	SA	EB	EDINGER	NS	LYON
6211	SA	EB	EDINGER	FS	RITCHEY
6212	SA	EB	EDINGER	FS	BOYD

Bus Stop Maintenance

All Stop Locations

RFP 1-3408

Exhibit A

Attachment 2

OCTA_ID	CITY	DIR	STREET_OF_TRAVEL	LOC	CROSS_STREET
6213	SA	WB	EDINGER	FS	AUTO MALL
6214	SA	WB	EDINGER	FS	RITCHEY
6215	SA	WB	EDINGER	FS	LYON
6216	SA	WB	EDINGER	VNS	GRAND
6217	SA	WB	EDINGER	NS	GRAND
6218	SA	WB	EDINGER	FS	STANDARD
6219	SA	WB	EDINGER	FS	KILSON
6220	SA	WB	EDINGER	FS	MAPLE
6221	SA	WB	EDINGER	FS	MAIN
6222	SA	WB	EDINGER	FS	BROADWAY
6223	SA	WB	EDINGER	FS	VAN NESS
6224	SA	WB	EDINGER	FS	FLOWER
6225	SA	WB	EDINGER	FS	TOWNER
6226	SA	WB	EDINGER	FS	ROSEWOOD
6227	SA	WB	EDINGER	FS	BRISTOL
6228	SA	WB	EDINGER	FS	PACIFIC
6229	SA	WB	EDINGER	FS	CENTER
6230	SA	WB	EDINGER	FS	RAITT
6231	SA	WB	EDINGER	FS	SULLIVAN
6232	SA	WB	EDINGER	FS	FAIRVIEW
6233	SA	WB	EDINGER	FS	MOHAWK
6234	SA	WB	EDINGER	FS	NEWHOPE
6235	SA	WB	EDINGER	FS	CORTA
6236	SA	NB	EUCLID	NS	ROBERTS
6237	SA	NB	EUCLID	FS	MCFADDEN
6238	SA	NB	EUCLID	OPP	BARBETTE
6239	SA	NB	EUCLID	FS	1ST
6240	SA	NB	EUCLID	FS	5TH
6241	SA	NB	EUCLID	FS	HAZARD
6242	SA	NB	EUCLID	FS	OAKFIELD
6243	SA	SB	EUCLID	NS	4TH
6244	SA	SB	EUCLID	FS	1ST
6245	SA	SB	EUCLID	NS	BARBETTE
6246	SA	SB	EUCLID	NS	MCFADDEN
6247	SA	SB	EUCLID	FS	MCFADDEN
6248	SA	SB	EUCLID	OPP	ROBERTS
6249	SA	WB	FAIRHAVEN	FS	LYNWOOD
6250	SA	NB	FAIRVIEW	FS	SUNFLOWER
6251	SA	NB	FAIRVIEW	FS	MACARTHUR
6252	SA	NB	FAIRVIEW	NS	ALTON
6253	SA	NB	FAIRVIEW	OPP	GARRY
6254	SA	NB	FAIRVIEW	FS	SEGERSTROM
6255	SA	NB	FAIRVIEW	FS	ENT 2701 CHERRY
6256	SA	NB	FAIRVIEW	OPP	CENTRAL
6257	SA	NB	FAIRVIEW	FS	WARNER
6258	SA	NB	FAIRVIEW	FS	HARVARD

Bus Stop Maintenance

All Stop Locations

RFP 1-3408

Exhibit A

Attachment 2

OCTA_ID	CITY	DIR	STREET_OF_TRAVEL	LOC	CROSS_STREET
6259	SA	NB	FAIRVIEW	FS	SAINT ANDREW
6260	SA	NB	FAIRVIEW	NS	EDINGER
6261	SA	NB	FAIRVIEW	FS	BORCHARD
6262	SA	NB	FAIRVIEW	FS	DAHL
6263	SA	NB	FAIRVIEW	FS	MCFADDEN
6264	SA	NB	FAIRVIEW	OPP	HIGHLAND
6265	SA	NB	FAIRVIEW	FS	WILLITS
6266	SA	NB	FAIRVIEW	FS	1ST
6267	SA	NB	FAIRVIEW	FS	5TH
6268	SA	NB	FAIRVIEW	FS	CIVIC CENTER
6269	SA	NB	FAIRVIEW	OPP	12TH
6270	SA	NB	FAIRVIEW	FS	WESTMINSTER
6271	SA	NB	FAIRVIEW	NS	EDNA
6272	SA	NB	FAIRVIEW	NS	TRASK
6273	SA	NB	FAIRVIEW	FS	DOWNIE
6274	SA	SB	FAIRVIEW	NS	STRAWBERRY
6275	SA	SB	FAIRVIEW	FS	WESTMINSTER
6276	SA	SB	FAIRVIEW	VFS	12TH
6277	SA	SB	FAIRVIEW	NS	9TH
6278	SA	SB	FAIRVIEW	OPP	CIVIC CENTER
6279	SA	SB	FAIRVIEW	FS	5TH
6280	SA	SB	FAIRVIEW	FS	1ST
6281	SA	SB	FAIRVIEW	FS	WILLITS
6282	SA	SB	FAIRVIEW	FS	HIGHLAND
6283	SA	SB	FAIRVIEW	FS	MCFADDEN
6284	SA	SB	FAIRVIEW	FS	DAHL
6285	SA	SB	FAIRVIEW	NS	EDINGER
6286	SA	SB	FAIRVIEW	FS	CENTENNIAL
6287	SA	SB	FAIRVIEW	FS	HARVARD
6288	SA	SB	FAIRVIEW	FS	WARNER
6289	SA	SB	FAIRVIEW	FS	CENTRAL
6290	SA	SB	FAIRVIEW	NS	ENT 2722 PHILLIPS
6291	SA	SB	FAIRVIEW	FS	SEGERSTROM
6292	SA	SB	FAIRVIEW	NS	GARRY
6293	SA	SB	FAIRVIEW	NS	ALTON
6294	SA	SB	FAIRVIEW	FS	MACARTHUR
6295	SA	NB	FLOWER	NS	MACARTHUR
6296	SA	NB	FLOWER	NS	ALTON
6297	SA	NB	FLOWER	NS	DYER
6298	SA	NB	FLOWER	OPP	CENTRAL
6299	SA	NB	FLOWER	FS	WARNER
6300	SA	NB	FLOWER	FS	SAINT GERTRUDE
6301	SA	NB	FLOWER	FS	SAINT ANDREW
6302	SA	NB	FLOWER	NS	EDINGER
6303	SA	NB	FLOWER	FS	WILSHIRE
6304	SA	NB	FLOWER	NS	MCFADDEN

Bus Stop Maintenance

RFP 1-3408

All Stop Locations

Exhibit A

Attachment 2

OCTA_ID	CITY	DIR	STREET_OF_TRAVEL	LOC	CROSS_STREET
6305	SA	NB	FLOWER	FS	RICHLAND
6306	SA	NB	FLOWER	FS	MYRTLE
6307	SA	NB	FLOWER	FS	1ST
6308	SA	NB	FLOWER	FS	SANTA ANA
6309	SA	NB	FLOWER	FS	6TH
6310	SA	NB	FLOWER	FS	CIVIC CENTER
6311	SA	NB	FLOWER	FS	10TH
6312	SA	NB	FLOWER	FS	WASHINGTON
6313	SA	NB	FLOWER	FS	15TH
6314	SA	SB	FLOWER	FS	15TH
6315	SA	SB	FLOWER	NS	WASHINGTON
6316	SA	SB	FLOWER	FS	10TH
6317	SA	SB	FLOWER	FS	CIVIC CENTER
6318	SA	SB	FLOWER	NS	6TH
6319	SA	SB	FLOWER	FS	6TH
6320	SA	SB	FLOWER	FS	SANTA ANA
6321	SA	SB	FLOWER	NS	WALNUT
6322	SA	SB	FLOWER	FS	CHESTNUT
6323	SA	SB	FLOWER	OPP	RICHLAND
6324	SA	SB	FLOWER	FS	MCFADDEN
6325	SA	SB	FLOWER	FS	WILSHIRE
6326	SA	SB	FLOWER	FS	EDINGER
6327	SA	SB	FLOWER	FS	BERKELEY
6328	SA	SB	FLOWER	FS	SAINT ANDREW
6329	SA	SB	FLOWER	FS	SAINT GERTRUDE
6330	SA	SB	FLOWER	FS	WARNER
6331	SA	SB	FLOWER	FS	CENTRAL
6332	SA	SB	FLOWER	FS	SEGERSTROM
6333	SA	SB	FLOWER	FS	ALTON
6334	SA	SB	FLOWER	FS	COLUMBINE
6335	SA	SB	FLOWER	FS	MACARTHUR
6336	SA	SB	FLOWER	FS	KELLER
6337	SA	WB	FRUIT	FS	GRAND
6338	SA	NB	GRAND	FS	BROOKHOLLOW
6339	SA	NB	GRAND	FS	WARNER
6340	SA	NB	GRAND	FS	SAINT GERTRUDE
6341	SA	NB	GRAND	FS	SAINT ANDREW
6342	SA	NB	GRAND	FS	EDINGER
6343	SA	NB	GRAND	OPP	WILSHIRE
6344	SA	NB	GRAND	VNS	MCFADDEN
6345	SA	NB	GRAND	FS	MCFADDEN
6346	SA	NB	GRAND	OPP	WAKEHAM
6347	SA	NB	GRAND	NS	CHESTNUT
6348	SA	NB	GRAND	FS	1ST
6349	SA	NB	GRAND	FS	2ND
6350	SA	NB	GRAND	FS	4TH

Bus Stop Maintenance

All Stop Locations

RFP 1-3408

Exhibit A

Attachment 2

OCTA_ID	CITY	DIR	STREET_OF_TRAVEL	LOC	CROSS_STREET
6351	SA	NB	GRAND	FS	ENT ORANGE COUNTY
6352	SA	NB	GRAND	FS	FRUIT
6353	SA	NB	GRAND	FS	WASHINGTON
6354	SA	NB	GRAND	NS	14TH
6355	SA	NB	GRAND	NS	15TH
6356	SA	NB	GRAND	FS	17TH
6357	SA	NB	GRAND	OPP	21ST
6358	SA	NB	GRAND	NS	SANTA CLARA
6359	SA	NB	GRAND	OPP	GROVEMONT
6360	SA	NB	GRAND	FS	FAIRHAVEN
6361	SA	SB	GRAND	FS	FAIRHAVEN
6362	SA	SB	GRAND	FS	GROVEMONT
6363	SA	SB	GRAND	FS	SANTA CLARA
6364	SA	SB	GRAND	FS	21ST
6365	SA	SB	GRAND	NS	17TH
6366	SA	SB	GRAND	FS	15TH
6367	SA	SB	GRAND	FS	SANTA ANA
6368	SA	SB	GRAND	NS	STAFFORD
6369	SA	SB	GRAND	NS	6TH
6370	SA	SB	GRAND	FS	4TH
6371	SA	SB	GRAND	FS	1ST
6372	SA	SB	GRAND	FS	CHESTNUT
6373	SA	SB	GRAND	FS	WAKEHAM
6374	SA	SB	GRAND	FS	MCFADDEN
6375	SA	SB	GRAND	NS	WILSHIRE
6376	SA	SB	GRAND	FS	EDINGER
6377	SA	SB	GRAND	FS	POMONA
6378	SA	SB	GRAND	FS	SAINT ANDREW
6379	SA	SB	GRAND	FS	SAINT GERTRUDE
6380	SA	SB	GRAND	FS	WARNER
6381	SA	SB	GRAND	FS	HOTEL TERRACE
6382	SA	NB	GREENVILLE	FS	PENDLETON
6383	SA	NB	GREENVILLE	FS	SAINT GERTRUDE
6384	SA	NB	GREENVILLE	FS	GLENWOOD
6385	SA	NB	GREENVILLE	OPP	OCCIDENTAL
6386	SA	NB	GREENVILLE	NS	POMONA
6387	SA	SB	GREENVILLE	NS	STANFORD
6388	SA	SB	GREENVILLE	FS	OCCIDENTAL
6389	SA	SB	GREENVILLE	NS	CASTOR
6390	SA	SB	GREENVILLE	FS	CAMDEN
6391	SA	SB	GREENVILLE	VNS	PENDLETON
6392	SA	NB	HALLADAY	@	2929 HALLADAY ST
6393	SA	NB	HALLADAY	FS	DYER
6394	SA	NB	HALLADAY	NS	EMMETT
6395	SA	NB	HALLADAY	NS	CENTRAL
6396	SA	NB	HALLADAY	NS	WARNER

Bus Stop Maintenance

RFP 1-3408

All Stop Locations

Exhibit A

Attachment 2

OCTA_ID	CITY	DIR	STREET_OF_TRAVEL	LOC	CROSS_STREET
6397	SA	SB	HALLADAY	FS	WARNER
6398	SA	SB	HALLADAY	NS	CENTRAL
6399	SA	SB	HALLADAY	NS	GOETZ
6400	SA	SB	HALLADAY	NS	DYER
6401	SA	SB	HALLADAY	@	3020 HALLADAY ST
6402	SA	NB	HARBOR	FS	SUNFLOWER
6403	SA	NB	HARBOR	FS	LAKE CENTER
6404	SA	NB	HARBOR	FS	MACARTHUR
6405	SA	NB	HARBOR	FS	GARRY
6406	SA	NB	HARBOR	FS	CARRIAGE
6407	SA	NB	HARBOR	FS	SEGERSTROM
6408	SA	NB	HARBOR	FS	WARNER
6409	SA	NB	HARBOR	FS	KENT
6410	SA	NB	HARBOR	FS	MCFADDEN
6411	SA	NB	HARBOR	FS	CAMILLE
6412	SA	NB	HARBOR	NS	1ST
6413	SA	NB	HARBOR	FS	5TH
6414	SA	NB	HARBOR	FS	HAZARD
6415	SA	NB	HARBOR	FS	WASHINGTON
6416	SA	NB	HARBOR	NS	WESTMINSTER
6417	SA	SB	HARBOR	FS	WESTMINSTER
6418	SA	SB	HARBOR	OPP	WASHINGTON
6419	SA	SB	HARBOR	FS	HAZARD
6420	SA	SB	HARBOR	NS	5TH
6421	SA	SB	HARBOR	FS	1ST
6422	SA	SB	HARBOR	OPP	CAMILLE
6423	SA	SB	HARBOR	FS	MCFADDEN
6424	SA	SB	HARBOR	NS	KENT
6425	SA	SB	HARBOR	FS	WARNER
6426	SA	SB	HARBOR	FS	CRODDY
6427	SA	SB	HARBOR	FS	SEGERSTROM
6428	SA	SB	HARBOR	FS	GARRY
6429	SA	EB	HARVARD	NS	SUSAN
6430	SA	WB	HARVARD	FS	FAIRVIEW
6431	SA	WB	HARVARD	FS	SUSAN
6432	SA	NB	HUTTON CENTRE	OPP	SANDPOINTE
6433	SA	NB	LAWSON	FS	MEMORY
6434	SA	NB	LYON	FS	EDINGER
6435	SA	NB	LYON	FS	MCFADDEN
6436	SA	NB	LYON	FS	NORMANDY
6437	SA	NB	LYON	FS	ENT 727 NANTUCKET
6438	SA	NB	LYON	OPP	WARREN
6439	SA	NB	LYON	NS	CHESTNUT
6440	SA	SB	LYON	FS	CHESTNUT
6441	SA	SB	LYON	NS	WARREN
6442	SA	SB	LYON	NS	ENT 710 WARWICK

Bus Stop Maintenance

RFP 1-3408

All Stop Locations

Exhibit A

Attachment 2

OCTA_ID	CITY	DIR	STREET_OF_TRAVEL	LOC	CROSS_STREET
6443	SA	SB	LYON	OPP	NORMANDY
6444	SA	EB	MACARTHUR	FS	HARBOR
6445	SA	EB	MACARTHUR	FS	HOME DEPOT
6446	SA	EB	MACARTHUR	FS	SUSAN
6447	SA	EB	MACARTHUR	FS	FAIRVIEW
6448	SA	EB	MACARTHUR	FS	GREENVILLE
6449	SA	EB	MACARTHUR	FS	RAITT
6450	SA	EB	MACARTHUR	FS	TWILIGHT
6451	SA	EB	MACARTHUR	FS	BEAR
6452	SA	EB	MACARTHUR	FS	PLAZA
6453	SA	EB	MACARTHUR	FS	BRISTOL
6454	SA	EB	MACARTHUR	FS	ENT 1000 MACARTHUR
6455	SA	EB	MACARTHUR	OPP	TOWNER
6456	SA	EB	MACARTHUR	FS	FLOWER
6457	SA	EB	MACARTHUR	FS	PARTON
6458	SA	EB	MACARTHUR	FS	BIRCH
6459	SA	EB	MACARTHUR	FS	MAIN
6460	SA	EB	MACARTHUR	FS	HUTTON CENTRE
6461	SA	WB	MACARTHUR	FS	IMPERIAL PROMENADE
6462	SA	WB	MACARTHUR	FS	MAIN
6463	SA	WB	MACARTHUR	FS	BIRCH
6464	SA	WB	MACARTHUR	FS	PARTON
6465	SA	WB	MACARTHUR	FS	FLOWER
6466	SA	WB	MACARTHUR	FS	TOWNER
6467	SA	WB	MACARTHUR	FS	ENT 1101 SOUTH COAST
6468	SA	WB	MACARTHUR	FS	BRISTOL
6469	SA	WB	MACARTHUR	NS	PLAZA
6470	SA	WB	MACARTHUR	FS	GREENVILLE
6471	SA	WB	MACARTHUR	FS	FAIRVIEW
6472	SA	WB	MACARTHUR	FS	SUSAN
6473	SA	WB	MACARTHUR	VNS	HARBOR
6474	SA	WB	MACARTHUR	FS	HARBOR
6475	SA	WB	MACARTHUR	FS	CRODDY
6476	SA	WB	MACARTHUR	OPP	HYLAND
6477	SA	NB	MAIN	OPP	SUNFLOWER
6478	SA	NB	MAIN	FS	SANDPOINTE
6479	SA	NB	MAIN	FS	MACARTHUR
6480	SA	NB	MAIN	FS	ALTON
6481	SA	NB	MAIN	FS	DYER
6482	SA	NB	MAIN	NS	GOETZ
6483	SA	NB	MAIN	NS	CENTRAL
6484	SA	NB	MAIN	FS	WARNER
6485	SA	NB	MAIN	NS	ANAHURST
6486	SA	NB	MAIN	NS	SAINT GERTRUDE
6487	SA	NB	MAIN	NS	SAINT ANDREW
6488	SA	NB	MAIN	FS	BERKELEY

Bus Stop Maintenance

RFP 1-3408

All Stop Locations

Exhibit A

Attachment 2

OCTA_ID	CITY	DIR	STREET_OF_TRAVEL	LOC	CROSS_STREET
6489	SA	NB	MAIN	FS	STANFORD
6490	SA	NB	MAIN	FS	EDINGER
6491	SA	NB	MAIN	FS	HOBART
6492	SA	NB	MAIN	NS	OXFORD
6493	SA	NB	MAIN	FS	MCFADDEN
6494	SA	NB	MAIN	NS	CUBBON
6495	SA	NB	MAIN	OPP	HIGHLAND
6496	SA	NB	MAIN	FS	BISHOP
6497	SA	NB	MAIN	NS	CHESTNUT
6498	SA	NB	MAIN	NS	1ST
6499	SA	NB	MAIN	NS	4TH
6500	SA	NB	MAIN	FS	CIVIC CENTER
6501	SA	NB	MAIN	NS	10TH
6502	SA	NB	MAIN	NS	WASHINGTON
6503	SA	NB	MAIN	NS	15TH
6504	SA	NB	MAIN	FS	17TH
6505	SA	NB	MAIN	FS	20TH
6506	SA	NB	MAIN	OPP	BUFFALO
6507	SA	NB	MAIN	FS	EDGEWOOD
6508	SA	NB	MAIN	FS	MEMORY
6509	SA	SB	MAIN	FS	MAIN PLACE
6510	SA	SB	MAIN	FS	MAIN PLACE
6511	SA	SB	MAIN	FS	BUFFALO
6512	SA	SB	MAIN	FS	20TH
6513	SA	SB	MAIN	NS	17TH
6514	SA	SB	MAIN	NS	15TH
6515	SA	SB	MAIN	NS	WASHINGTON
6516	SA	SB	MAIN	FS	10TH
6517	SA	SB	MAIN	NS	CIVIC CENTER
6518	SA	SB	MAIN	FS	SANTA ANA
6519	SA	SB	MAIN	FS	5TH
6520	SA	SB	MAIN	FS	3RD
6521	SA	SB	MAIN	FS	1ST
6522	SA	SB	MAIN	FS	CHESTNUT
6523	SA	SB	MAIN	NS	BISHOP
6524	SA	SB	MAIN	NS	HIGHLAND
6525	SA	SB	MAIN	FS	CUBBON
6526	SA	SB	MAIN	FS	RUSSELL
6527	SA	SB	MAIN	FS	WILSHIRE
6528	SA	SB	MAIN	FS	BORCHARD
6529	SA	SB	MAIN	NS	EDINGER
6530	SA	SB	MAIN	FS	POMONA
6531	SA	SB	MAIN	FS	SAINT ANDREW
6532	SA	SB	MAIN	FS	SAINT GERTRUDE
6533	SA	SB	MAIN	FS	ANAHURST
6534	SA	SB	MAIN	FS	WARNER

Bus Stop Maintenance

RFP 1-3408

All Stop Locations

Exhibit A

Attachment 2

OCTA_ID	CITY	DIR	STREET_OF_TRAVEL	LOC	CROSS_STREET
6535	SA	SB	MAIN	OPP	CENTRAL
6536	SA	SB	MAIN	OPP	GOETZ
6537	SA	SB	MAIN	FS	DYER
6538	SA	SB	MAIN	OPP	ALTON
6539	SA	SB	MAIN	FS	COLUMBINE
6540	SA	SB	MAIN	FS	MACARTHUR
6541	SA	SB	MAIN	FS	MURPHY
6542	SA	EB	MCFADDEN	FS	SAIL
6543	SA	EB	MCFADDEN	NS	MAXINE
6544	SA	EB	MCFADDEN	FS	EUCLID
6545	SA	EB	MCFADDEN	OPP	HARMON
6546	SA	EB	MCFADDEN	NS	NEWHOPE
6547	SA	EB	MCFADDEN	FS	SHANNON
6548	SA	EB	MCFADDEN	FS	HARBOR
6549	SA	EB	MCFADDEN	OPP	JACKSON
6550	SA	EB	MCFADDEN	NS	MOHAWK
6551	SA	EB	MCFADDEN	FS	FAIRVIEW
6552	SA	EB	MCFADDEN	NS	SULLIVAN
6553	SA	EB	MCFADDEN	NS	CENTER
6554	SA	EB	MCFADDEN	NS	RAITT
6555	SA	EB	MCFADDEN	OPP	PACIFIC
6556	SA	EB	MCFADDEN	NS	BRISTOL
6557	SA	EB	MCFADDEN	NS	BAKER
6558	SA	EB	MCFADDEN	FS	SHELTON
6559	SA	EB	MCFADDEN	NS	FLOWER
6560	SA	EB	MCFADDEN	FS	VAN NESS
6561	SA	EB	MCFADDEN	FS	MAPLE
6562	SA	EB	MCFADDEN	NS	HICKORY
6563	SA	EB	MCFADDEN	NS	STANDARD
6564	SA	EB	MCFADDEN	OPP	HATHAWAY
6565	SA	EB	MCFADDEN	FS	GRAND
6566	SA	EB	MCFADDEN	NS	WRIGHT
6567	SA	EB	MCFADDEN	FS	LYON
6568	SA	EB	MCFADDEN	NS	RITCHEY
6569	SA	EB	MCFADDEN	OPP	WILLIAMS
6570	SA	EB	MCFADDEN	NS	VILLAGE
6571	SA	WB	MCFADDEN	FS	RAITT
6572	SA	WB	MCFADDEN	FS	LYON
6573	SA	WB	MCFADDEN	NS	LINWOOD
6574	SA	WB	MCFADDEN	FS	GRAND
6575	SA	WB	MCFADDEN	FS	HATHAWAY
6576	SA	WB	MCFADDEN	FS	STANDARD
6577	SA	WB	MCFADDEN	NS	CEDAR
6578	SA	WB	MCFADDEN	NS	OAK
6579	SA	WB	MCFADDEN	FS	SYCAMORE
6580	SA	WB	MCFADDEN	FS	BIRCH

Bus Stop Maintenance

RFP 1-3408

All Stop Locations

Exhibit A

Attachment 2

OCTA_ID	CITY	DIR	STREET_OF_TRAVEL	LOC	CROSS_STREET
6581	SA	WB	MCFADDEN	NS	VAN NESS
6582	SA	WB	MCFADDEN	NS	FLOWER
6583	SA	WB	MCFADDEN	NS	SHELTON
6584	SA	WB	MCFADDEN	FS	BAKER
6585	SA	WB	MCFADDEN	FS	BRISTOL
6586	SA	WB	MCFADDEN	FS	PACIFIC
6587	SA	WB	MCFADDEN	FS	CENTER
6588	SA	WB	MCFADDEN	FS	SULLIVAN
6589	SA	WB	MCFADDEN	NS	FAIRVIEW
6590	SA	WB	MCFADDEN	VFS	MOHAWK
6591	SA	WB	MCFADDEN	OPP	RIVERVIEW MARKET PLACE
6592	SA	WB	MCFADDEN	NS	HARBOR
6593	SA	WB	MCFADDEN	FS	DENNIS
6594	SA	WB	MCFADDEN	OPP	SHANNON
6595	SA	WB	MCFADDEN	FS	NEWHOPE
6596	SA	WB	MCFADDEN	@	CORTA
6597	SA	WB	MCFADDEN	FS	EUCLID
6598	SA	WB	MCFADDEN	FS	MAXINE
6599	SA	WB	MCFADDEN	NS	SAIL
6600	SA	EB	MEMORY	FS	PACIFIC
6601	SA	EB	MEMORY	FS	MAIN
6602	SA	WB	MEMORY	FS	ENT TOWN & COUNTRY MANOR
6603	SA	WB	MEMORY	FS	BRISTOL
6604	SA	NB	MORTIMER	NS	6TH
6605	SA	NB	NEWHOPE	NS	MCFADDEN
6606	SA	NB	NEWHOPE	FS	REGENT
6607	SA	NB	NEWHOPE	FS	KENT
6608	SA	NB	NEWHOPE	FS	CAMILLE
6609	SA	NB	NEWHOPE	FS	1ST
6610	SA	NB	NEWHOPE	NS	SILVER
6611	SA	NB	NEWHOPE	FS	HAZARD
6612	SA	NB	NEWHOPE	@	MAURIE
6613	SA	NB	NEWHOPE	NS	SUNSWEPT
6614	SA	SB	NEWHOPE	FS	WESTMINSTER
6615	SA	SB	NEWHOPE	FS	SUNSWEPT
6616	SA	SB	NEWHOPE	FS	MAURIE
6617	SA	SB	NEWHOPE	FS	HAZARD
6618	SA	SB	NEWHOPE	FS	5TH
6619	SA	SB	NEWHOPE	FS	1ST
6620	SA	SB	NEWHOPE	OPP	CAMILLE
6621	SA	SB	NEWHOPE	FS	MCFADDEN
6622	SA	SB	NEWHOPE	NS	FLIGHT
6623	SA	SB	NEWHOPE	OPP	REGENT
6624	SA	NB	PULLMAN	FS	DYER
6625	SA	NB	PULLMAN	FS	NORTH ENT 2331 TROY
6626	SA	NB	RAITT	FS	MCFADDEN

Bus Stop Maintenance

All Stop Locations

RFP 1-3408

Exhibit A

Attachment 2

OCTA_ID	CITY	DIR	STREET_OF_TRAVEL	LOC	CROSS_STREET
6627	SA	NB	RAITT	FS	WISTERIA
6628	SA	NB	RAITT	FS	WILLITS
6629	SA	NB	RAITT	FS	CHESTNUT
6630	SA	NB	RAITT	FS	WALNUT
6631	SA	NB	RAITT	NS	SANTA ANA
6632	SA	NB	RAITT	FS	5TH
6633	SA	NB	RAITT	FS	7TH
6634	SA	SB	RAITT	OPP	7TH
6635	SA	SB	RAITT	FS	5TH
6636	SA	SB	RAITT	NS	3RD
6637	SA	SB	RAITT	FS	1ST
6638	SA	SB	RAITT	FS	PINE
6639	SA	SB	RAITT	FS	WILLITS
6640	SA	SB	RAITT	OPP	WISTERIA
6641	SA	SB	RED HILL	FS	WARNER
6642	SA	SB	RED HILL	FS	CARNEGIE
6643	SA	SB	RED HILL	NS	DYER
6644	SA	SB	RED HILL	FS	DYER
6645	SA	SB	RED HILL	FS	DEERE
6646	SA	SB	RITCHEY	NS	EDINGER
6647	SA	NB	ROSS	FS	SANTA ANA
6648	SA	NB	ROSS	NS	3RD
6649	SA	NB	ROSS	NS	4TH
6650	SA	SB	ROSS	FS	CIVIC CENTER
6651	SA	SB	ROSS	FS	SANTA ANA
6652	SA	SB	ROSS	FS	3RD
6653	SA	EB	SAINT ANDREW	NS	WOODLAND
6654	SA	EB	SAINT ANDREW	NS	ROSS
6655	SA	EB	SAINT ANDREW	FS	MAIN
6656	SA	EB	SAINT ANDREW	FS	ROUSSELLE
6657	SA	EB	SAINT ANDREW	FS	KILSON
6658	SA	EB	SAINT ANDREW	FS	HALLADAY
6659	SA	EB	SAINT ANDREW	FS	EVERGREEN
6660	SA	WB	SAINT ANDREW	FS	EVERGREEN
6661	SA	WB	SAINT ANDREW	FS	HALLADAY
6662	SA	WB	SAINT ANDREW	FS	KILSON
6663	SA	WB	SAINT ANDREW	FS	MAPLE
6664	SA	WB	SAINT ANDREW	FS	MAIN
6665	SA	WB	SAINT ANDREW	FS	VAN NESS
6666	SA	EB	SAINT GERTRUDE	NS	SANTA FE
6667	SA	EB	SAINT GERTRUDE	FS	HATHAWAY
6668	SA	WB	SAINT GERTRUDE	NS	EASTWOOD
6669	SA	WB	SAINT GERTRUDE	OPP	SANTA FE
6670	SA	EB	SANTA ANA	NS	PACIFIC
6671	SA	EB	SANTA ANA	FS	BRISTOL
6672	SA	EB	SANTA ANA	NS	SHELTON

Bus Stop Maintenance

RFP 1-3408

All Stop Locations

Exhibit A

Attachment 2

OCTA_ID	CITY	DIR	STREET_OF_TRAVEL	LOC	CROSS_STREET
6673	SA	EB	SANTA ANA	NS	FLOWER
6674	SA	EB	SANTA ANA	NS	PARTON
6675	SA	EB	SANTA ANA	FS	LACY
6676	SA	EB	SANTA ANA	VFS	SANTIAGO
6677	SA	EB	SANTA ANA	FS	FULLER
6678	SA	EB	SANTA ANA	VNS	GRAND
6679	SA	WB	SANTA ANA	FS	GRAND
6680	SA	WB	SANTA ANA	FS	FULLER
6681	SA	WB	SANTA ANA	NS	SANTIAGO
6682	SA	WB	SANTA ANA	FS	POINSETTIA
6683	SA	WB	SANTA ANA	FS	LACY
6684	SA	WB	SANTA ANA	NS	MORTIMER
6685	SA	WB	SANTA ANA	FS	SPURGEON
6686	SA	WB	SANTA ANA	FS	MAIN
6687	SA	WB	SANTA ANA	VNS	ROSS
6688	SA	WB	SANTA ANA	FS	ROSS
6689	SA	WB	SANTA ANA	OPP	PARTON
6690	SA	WB	SANTA ANA	FS	FLOWER
6691	SA	WB	SANTA ANA	NS	SHELTON
6692	SA	WB	SANTA ANA	FS	BAKER
6693	SA	WB	SANTA ANA	FS	BRISTOL
6694	SA	WB	SANTA ANA	NS	PACIFIC
6695	SA	WB	SANTA ANA	FS	WESTERN
6696	SA	NB	STANDARD	FS	SAINT GERTRUDE
6697	SA	NB	STANDARD	NS	GLENWOOD
6698	SA	NB	STANDARD	OPP	SAINT ANDREW
6699	SA	NB	STANDARD	OPP	OCCIDENTAL
6700	SA	NB	STANDARD	FS	EDINGER
6701	SA	NB	STANDARD	NS	WILSHIRE
6702	SA	NB	STANDARD	NS	MCFADDEN
6703	SA	NB	STANDARD	FS	WAKEHAM
6704	SA	NB	STANDARD	FS	BISHOP
6705	SA	SB	STANDARD	FS	CHESTNUT
6706	SA	SB	STANDARD	FS	BISHOP
6707	SA	SB	STANDARD	FS	WAKEHAM
6708	SA	SB	STANDARD	FS	MCFADDEN
6709	SA	SB	STANDARD	FS	HOBART
6710	SA	SB	STANDARD	FS	EDINGER
6711	SA	SB	STANDARD	NS	OCCIDENTAL
6712	SA	SB	STANDARD	FS	SAINT ANDREW
6713	SA	WB	SUNFLOWER	FS	MAIN
6714	SA	WB	SUNFLOWER	OPP	ANTON
6715	SA	WB	SUNFLOWER	FS	BRISTOL
6716	SA	WB	SUNFLOWER	FS	PLAZA
6717	SA	WB	SUNFLOWER	NS	RAITT
6718	SA	WB	SUNFLOWER	OPP	SMALLEY

Bus Stop Maintenance

RFP 1-3408

All Stop Locations

Exhibit A

Attachment 2

OCTA_ID	CITY	DIR	STREET_OF_TRAVEL	LOC	CROSS_STREET
6719	SA	WB	SUNFLOWER	FS	GREENVILLE
6720	SA	WB	SUNFLOWER	FS	FAIRVIEW
6721	SA	WB	SUNFLOWER	FS	SUSAN
6722	SA	WB	SUNFLOWER	VNS	HARBOR
6723	SA	SB	SYCAMORE	NS	MCFADDEN
6724	SA	NB	TUSTIN	FS	4TH
6725	SA	NB	TUSTIN	OPP	6TH
6726	SA	NB	TUSTIN	OPP	FRUIT
6727	SA	NB	TUSTIN	OPP	WELLINGTON
6728	SA	NB	TUSTIN	FS	CATALINA
6729	SA	NB	TUSTIN	FS	SANTA CLARA
6730	SA	NB	TUSTIN	FS	FRANZEN
6731	SA	SB	TUSTIN	OPP	FRANZEN
6732	SA	SB	TUSTIN	FS	SANTA CLARA
6733	SA	SB	TUSTIN	FS	CATALINA
6734	SA	SB	TUSTIN	FS	17TH
6735	SA	SB	TUSTIN	VNS	WELLINGTON
6736	SA	SB	TUSTIN	FS	WELLINGTON
6737	SA	SB	TUSTIN	FS	FRUIT
6738	SA	SB	TUSTIN	NS	6TH
6739	SA	SB	TUSTIN	FS	4TH
6740	SA	EB	WARNER	FS	HARBOR
6741	SA	EB	WARNER	OPP	YALE
6742	SA	EB	WARNER	NS	SUSAN
6743	SA	EB	WARNER	FS	FAIRVIEW
6744	SA	EB	WARNER	FS	GREENVILLE
6745	SA	EB	WARNER	FS	DIAMOND
6746	SA	EB	WARNER	FS	RAITT
6747	SA	EB	WARNER	FS	LINDA
6748	SA	EB	WARNER	FS	PACIFIC
6749	SA	EB	WARNER	FS	BRISTOL
6750	SA	EB	WARNER	OPP	ROSEWOOD
6751	SA	EB	WARNER	FS	FLOWER
6752	SA	EB	WARNER	FS	GARNSEY
6753	SA	EB	WARNER	OPP	VAN NESS
6754	SA	EB	WARNER	FS	BIRCH
6755	SA	EB	WARNER	FS	MAIN
6756	SA	EB	WARNER	FS	MAPLE
6757	SA	EB	WARNER	NS	HALLADAY
6758	SA	EB	WARNER	OPP	STANDARD
6759	SA	EB	WARNER	FS	GRAND
6760	SA	EB	WARNER	NS	BROOKHOLLOW
6761	SA	EB	WARNER	FS	PULLMAN
6762	SA	EB	WARNER	NS	RED HILL
6763	SA	WB	WARNER	FS	WRIGHT
6764	SA	WB	WARNER	FS	GRAND

Bus Stop Maintenance
All Stop Locations

RFP 1-3408
Exhibit A
Attachment 2

OCTA_ID	CITY	DIR	STREET_OF_TRAVEL	LOC	CROSS_STREET
6765	SA	WB	WARNER	FS	HATHAWAY
6766	SA	WB	WARNER	FS	STANDARD
6767	SA	WB	WARNER	NS	HALLADAY
6768	SA	WB	WARNER	NS	MAPLE
6769	SA	WB	WARNER	FS	MAIN
6770	SA	WB	WARNER	OPP	BIRCH
6771	SA	WB	WARNER	FS	FLOWER
6772	SA	WB	WARNER	FS	SHELTON
6773	SA	WB	WARNER	FS	BRISTOL
6774	SA	WB	WARNER	FS	PACIFIC
6775	SA	WB	WARNER	FS	RENE
6776	SA	WB	WARNER	FS	LINDA
6777	SA	WB	WARNER	FS	RAITT
6778	SA	WB	WARNER	FS	CENTER
6779	SA	WB	WARNER	FS	GREENVILLE
6780	SA	WB	WARNER	FS	FAIRVIEW
6781	SA	WB	WARNER	FS	SUSAN
6782	SA	WB	WARNER	NS	YALE
6783	SA	WB	WARNER	FS	HARBOR
6784	SA	EB	WASHINGTON	FS	PACIFIC
6785	SA	WB	WILSHIRE	VNS	LYON
6786	SA	NB	YALE	OPP	PENDLETON
6787	SA	NB	YALE	FS	MAYWOOD
6788	SA	SB	YALE	OPP	FORDHAM
6789	SA	SB	YALE	NS	PENDLETON
6790	SA	EB	HAZARD	NS	MICHAEL
6791	SA	EB	HAZARD	FS	EUCLID
6792	SA	EB	HAZARD	FS	ROSITA
6793	SA	EB	HAZARD	FS	NEWHOPE
6794	SA	EB	HAZARD	NS	MORSE
6795	SA	WB	HAZARD	FS	HARBOR
6796	SA	WB	HAZARD	FS	WEST
6797	SA	WB	HAZARD	NS	NEWHOPE
6798	SA	WB	HAZARD	OPP	ROSITA
6799	SA	WB	HAZARD	NS	EUCLID
6800	SA	NB	THE DEPOT	@	DOCK 1
6801	SA	NB	THE DEPOT	@	DOCK 2
6802	SA	WB	THE DEPOT	@	DOCK 9
6803	SA	WB	THE DEPOT	@	DOCK 10
6804	SA	NB	THE DEPOT	@	BOARDING DOCK
6805	SA	SB	SATT	@	DOCK 1
6806	SA	SB	SATT	@	DOCK 2
6807	SA	SB	SATT	@	DOCK 3
6808	SA	SB	SATT	@	DOCK 4
6809	SA	SB	SATT	@	DOCK 5
6810	SA	WB	SATT	@	DOCK 6

Bus Stop Maintenance

All Stop Locations

RFP 1-3408

Exhibit A

Attachment 2

OCTA_ID	CITY	DIR	STREET_OF_TRAVEL	LOC	CROSS_STREET
6811	SA	WB	SATT	@	DOCK 7
6812	SA	WB	SATT	@	DOCK 8
6813	SA	WB	SATT	@	DOCK 9
6814	SA	WB	SATT	@	DOCK 10
6815	SA	NB	SATT	@	DOCK 11
6816	SA	WB	SATT	@	DOCK 12
6817	SA	NB	SATT	@	DOCK 13
6818	SA	NB	SATT	@	DOCK 14
6819	SA	NB	SATT	@	DOCK 15
6820	SA	NB	SATT	@	DOCK 16
6821	SA	NB	SATT	@	DOCK 17
6822	SB	NB	BEVERLY MANOR	OPP	ENT 3000 BEVERLY
6823	SB	EB	BOLSA	OPP	SLIVER SHOALS
6824	SB	SB	BALBOA	FS	BOLSA
6825	SB	EB	ELECTRIC	FS	MAIN
6826	SB	EB	ELECTRIC	FS	12TH
6827	SB	WB	ELECTRIC	FS	17TH
6828	SB	WB	ELECTRIC	NS	15TH
6829	SB	WB	ELECTRIC	FS	12TH
6830	SB	WB	ELECTRIC	NS	MAIN
6831	SB	EB	LAMPSON	FS	OLD RANCH PLAZA
6832	SB	EB	LAMPSON	NS	BASSWOOD
6833	SB	EB	LAMPSON	FS	CANDLEBERRY
6834	SB	EB	LAMPSON	FS	HEATHER
6835	SB	EB	LAMPSON	OPP	ENT 4665 WESTED
6836	SB	EB	LAMPSON	FS	ROSE
6837	SB	EB	LAMPSON	FS	TULIP
6838	SB	WB	LAMPSON	NS	PARKEWOOD
6839	LOSAL	WB	LAMPSON	OPP	ROSE
6840	LOSAL	WB	LAMPSON	FS	ENT 4665 WEST-ED
6841	LOSAL	WB	LAMPSON	OPP	HEATHER
6842	SB	WB	LAMPSON	OPP	CANDLEBERRY
6843	SB	WB	LAMPSON	OPP	BASSWOOD
6844	SB	WB	LAMPSON	NS	SEAL BEACH
6845	SB	NB	MAIN	NS	PACIFIC COAST
6846	SB	SB	MAIN	FS	PACIFIC COAST
6847	SB	NB	PACIFIC COAST	FS	SEAL BEACH
6848	SB	NB	PACIFIC COAST	FS	BALBOA
6849	SB	NB	PACIFIC COAST	VFS	BALBOA
6850	SB	NB	PACIFIC COAST	FS	BOLSA
6851	SB	NB	PACIFIC COAST	FS	MARVISTA
6852	SB	NB	PACIFIC COAST	NS	1ST
6853	SB	SB	PACIFIC COAST	FS	1ST
6854	SB	SB	PACIFIC COAST	FS	5TH
6855	SB	SB	PACIFIC COAST	NS	10TH
6856	SB	SB	PACIFIC COAST	NS	12TH

Bus Stop Maintenance

All Stop Locations

RFP 1-3408

Exhibit A

Attachment 2

OCTA_ID	CITY	DIR	STREET_OF_TRAVEL	LOC	CROSS_STREET
6857	SB	SB	PACIFIC COAST	NS	15TH
6858	SB	SB	PACIFIC COAST	FS	SEAL BEACH
6859	SB	SB	PACIFIC COAST	NS	ANDERSON
6860	SB	NB	SEAL BEACH	FS	ELECTRIC
6861	SB	NB	SEAL BEACH	FS	PACIFIC COAST
6862	SB	NB	SEAL BEACH	FS	ANCHOR
6863	SB	NB	SEAL BEACH	FS	FORRESTAL
6864	SB	NB	SEAL BEACH	OPP	C
6865	SB	NB	SEAL BEACH	FS	WESTMINSTER
6866	SB	NB	SEAL BEACH	OPP	BEVERLY MANOR
6867	SB	NB	SEAL BEACH	OPP	OLD RANCH
6868	SB	NB	SEAL BEACH	OPP	TOWNE CENTER
6869	SB	NB	SEAL BEACH	NS	PLYMOUTH
6870	SB	SB	SEAL BEACH	FS	BRADBURY
6871	SB	SB	SEAL BEACH	FS	ROSSMOOR CENTER
6872	SB	SB	SEAL BEACH	FS	TOWNE CENTER
6873	SB	SB	SEAL BEACH	OPP	LAMPSON
6874	SB	SB	SEAL BEACH	FS	OLD RANCH
6875	SB	SB	SEAL BEACH	FS	BEVERLY MANOR
6876	SB	SB	SEAL BEACH	FS	SAINT ANDREWS
6877	SB	SB	SEAL BEACH	FS	WESTMINSTER
6878	SB	SB	SEAL BEACH	FS	ENT 2201 BOEING
6879	SB	SB	SEAL BEACH	FS	ADOLFO LOPEZ
6880	SB	SB	SEAL BEACH	FS	FORRESTAL
6881	SB	SB	SEAL BEACH	FS	BOLSA
6882	SB	SB	SEAL BEACH	NS	MARLIN
6883	SB	SB	SEAL BEACH	FS	PACIFIC COAST
6884	SB	EB	WESTMINSTER	FS	ROAD A
6885	SB	EB	WESTMINSTER	FS	ROAD B
6886	SB	EB	WESTMINSTER	@	FIRST FEDERAL PLAZA
6887	SB	EB	WESTMINSTER	NS	SEAL BEACH
6888	SB	EB	WESTMINSTER	FS	KITTS
6889	SB	WB	WESTMINSTER	FS	KITTS
6890	SB	WB	WESTMINSTER	FS	SEAL BEACH
6891	SB	SB	LEISURE WORLD	@	GATE 1
6892	SC	NB	AVD DEL PRESIDENTE	FS	AVD SAN LUIS REY
6893	SC	SB	AVD DEL PRESIDENTE	FS	AVD CALIFIA
6894	SC	SB	AVD DEL PRESIDENTE	OPP	AVD SAN LUIS REY
6895	SC	SB	AVD DEL PRESIDENTE	NS	ENT CONCORDIA SCHOOL
6896	SC	SB	AVD DEL PRESIDENTE	NS	ENT 3410 MEADOWLARK
6897	SC	SB	AVD DEL PRESIDENTE	FS	AVD DE LAS PALMERAS
6898	SC	SB	AVD CALAFIA	NS	OLA VISTA
6899	SC	NB	OLA VISTA	FS	CALLE DEL PACIFICO
6900	SC	NB	OLA VISTA	FS	PASEO DE LA SERENATA
6901	SC	NB	OLA VISTA	FS	AVD SAN ANTONIO
6902	SC	NB	OLA VISTA	NS	AVD VALENCIA

Bus Stop Maintenance

RFP 1-3408

All Stop Locations

Exhibit A

Attachment 2

OCTA_ID	CITY	DIR	STREET_OF_TRAVEL	LOC	CROSS_STREET
6903	SC	NB	OLA VISTA	NS	AVD CORDOBA
6904	SC	NB	OLA VISTA	NS	ESPLANADE
6905	SC	NB	OLA VISTA	FS	AVD BARCELONA
6906	SC	SB	OLA VISTA	NS	AVD BARCELONA
6907	SC	SB	OLA VISTA	FS	ESPLANADE
6908	SC	SB	OLA VISTA	FS	AVD CORDOBA
6909	SC	SB	OLA VISTA	NS	AVD VALENCIA
6910	SC	SB	OLA VISTA	NS	CALLE MARINA
6911	SC	SB	OLA VISTA	FS	AVD ALESSANDRO
6912	SC	SB	OLA VISTA	NS	AVD DE LA RIVIERA
6913	SC	SB	OLA VISTA	OPP	CALLE DEL PACIFICO
6914	SC	WB	AVD MADRID	FS	OLA VISTA
6915	SC	EB	AVD MADRID	NS	OLA VISTA
6916	SC	EB	AVD VICTORIA	OPP	CORONA
6917	SC	WB	AVD VICTORIA	FS	CORONA
6918	SC	NB	AVD DEL MAR	NS	CORONADO
6919	SC	EB	AVD DEL MAR	FS	ACEBO
6920	SC	EB	AVD DEL MAR	FS	CALLE SEVILLE
6921	SC	EB	AVD DEL MAR	FS	OLA VISTA
6922	SC	WB	AVD DEL MAR	FS	EL CAMINO REAL
6923	SC	WB	AVD DEL MAR	FS	OLA VISTA
6924	SC	WB	AVD DEL MAR	NS	CALLE SEVILLE
6925	SC	WB	AVD DEL MAR	FS	AVD GRANADA
6926	SC	SB	AVD DEL MAR	OPP	CORONADO
6927	SC	NB	EL CAMINO REAL	NS	AVD SANTA MARGARITA
6928	SC	NB	EL CAMINO REAL	FS	AVD CARMELO
6929	SC	NB	EL CAMINO REAL	FS	AVD BUENA VENTURA
6930	SC	NB	EL CAMINO REAL	NS	AVD DOMINGUEZ
6931	SC	NB	EL CAMINO REAL	FS	AVD SAN LUIS REY
6932	SC	NB	EL CAMINO REAL	FS	CALLE DEL COMMERCIO
6933	SC	NB	EL CAMINO REAL	NS	AVD SAN GABRIEL
6934	SC	NB	EL CAMINO REAL	FS	AVD JUNIPERO
6935	SC	NB	EL CAMINO REAL	FS	AVD SAN JUAN
6936	SC	NB	EL CAMINO REAL	OPP	AVD GAVIOTA
6937	SC	NB	EL CAMINO REAL	OPP	AVD SANTIAGO
6938	SC	NB	EL CAMINO REAL	OPP	AVD BARCELONA
6939	SC	NB	EL CAMINO REAL	FS	AVD PRESIDIO
6940	SC	NB	EL CAMINO REAL	NS	AVD CABRILLO
6941	SC	NB	EL CAMINO REAL	OPP	AVD MIRAMAR
6942	SC	NB	EL CAMINO REAL	FS	AVD PALIZADA
6943	SC	NB	EL CAMINO REAL	NS	ESCALONES
6944	SC	NB	EL CAMINO REAL	NS	CANADA
6945	SC	NB	EL CAMINO REAL	NS	EL PORTAL
6946	SC	NB	EL CAMINO REAL	NS	CALLE VALLE
6947	SC	NB	EL CAMINO REAL	OPP	AVD DE LA GRULLA
6948	SC	NB	EL CAMINO REAL	FS	CALLE DE LOS MOLINOS

Bus Stop Maintenance

All Stop Locations

RFP 1-3408

Exhibit A

Attachment 2

OCTA_ID	CITY	DIR	STREET_OF_TRAVEL	LOC	CROSS_STREET
6949	SC	NB	EL CAMINO REAL	FS	AVD PICO
6950	SC	NB	EL CAMINO REAL	FS	CAMINO SAN CLEMENTE
6951	SC	SB	EL CAMINO REAL	NS	AVD PICO
6952	SC	SB	EL CAMINO REAL	OPP	CALLE DE LOS MOLINOS
6953	SC	SB	EL CAMINO REAL	FS	AVD DE LA GRULLA
6954	SC	SB	EL CAMINO REAL	NS	CANADA
6955	SC	SB	EL CAMINO REAL	FS	AVD MARIPOSA
6956	SC	SB	EL CAMINO REAL	NS	AVD PALIZADA
6957	SC	SB	EL CAMINO REAL	FS	AVD MIRAMAR
6958	SC	SB	EL CAMINO REAL	FS	AVD CABRILLO
6959	SC	SB	EL CAMINO REAL	FS	AVD ROSA
6960	SC	SB	EL CAMINO REAL	FS	TRAFALGAR
6961	SC	SB	EL CAMINO REAL	NS	AVD SANTIAGO
6962	SC	SB	EL CAMINO REAL	NS	AVD GAVIOTA
6963	SC	SB	EL CAMINO REAL	FS	AVD SAN ANTONIO
6964	SC	SB	EL CAMINO REAL	FS	AVD JUNIPERO
6965	SC	SB	EL CAMINO REAL	OPP	AVD SAN GABRIEL
6966	SC	SB	EL CAMINO REAL	OPP	CALLE DEL COMMERCIO
6967	SC	SB	EL CAMINO REAL	NS	AVD SAN LUIS REY
6968	SC	NB	AVD ESTACION	FS	CALLE DESHECHA
6969	SC	EB	AVD PICO	NS	CALLE DE LOS MOLINOS
6970	SC	EB	AVD PICO	NS	VIA PICO PLAZA
6971	SC	EB	AVD PICO	NS	ENT SAN CLEMENTE HIGH
6972	SC	EB	AVD PICO	FS	AVD PRESIDIO
6973	SC	WB	AVD PICO	NS	CALLE FRONTERA
6974	SC	WB	AVD PICO	OPP	ENT SAN CLEMENTE HIGH
6975	SC	WB	AVD PICO	FS	AVD NAVARRO
6976	SC	WB	AVD PICO	FS	CALLE DE LOS MOLINOS
6977	SC	EB	CALLE DEL CERRO	FS	LORCA
6978	SC	EB	CALLE DEL CERRO	NS	CAMINO IBIZA
6979	SC	EB	CALLE DEL CERRO	NS	CALLE VENEZIA
6980	SC	EB	CALLE DEL CERRO	OPP	CALLE SOL
6981	SC	EB	CALLE DEL CERRO	OPP	ENT 1100 WHISPERING
6982	SC	EB	CALLE DEL CERRO	FS	CALLE IGLESIA
6983	SC	WB	CALLE DEL CERRO	FS	ENT 1100 WHISPERING
6984	SC	EB	CALLE AMANECER	NS	CALLE SOMBRA
6985	SC	WB	CALLE AMANECER	NS	CALLE SOMBRA
6986	SC	WB	CALLE AMANECER	NS	CALLE RECODO
6987	SC	WB	CALLE AMANECER	NS	CALLE TREPADORA
6988	SC	WB	CALLE AMANECER	OPP	CALLE CORDILLERA
6989	SC	WB	CALLE AMANECER	NS	CALLE NEGOCIO
6990	SC	NB	CALLE FRONTERA	FS	AVD FACETA
6991	SC	NB	CALLE FRONTERA	OPP	CALLE OLA VERDE
6992	SC	NB	CALLE FRONTERA	FS	AVD VISTA HERMOSA
6993	SC	NB	CALLE FRONTERA	FS	CALLE GAUCHO
6994	SC	SB	CALLE FRONTERA	NS	CALLE GAUCHO

Bus Stop Maintenance

RFP 1-3408

All Stop Locations

Exhibit A

Attachment 2

OCTA_ID	CITY	DIR	STREET_OF_TRAVEL	LOC	CROSS_STREET
6995	SC	SB	CALLE FRONTERA	NS	VIA SARGO
6996	SC	SB	CALLE FRONTERA	NS	CALLE OLA VERDE
6997	SC	SB	CALLE FRONTERA	FS	AVD FUENTES
6998	SC	EB	CALLE GUADALAJARA	FS	CALLE HIDALGO
6999	SC	WB	CALLE GUADALAJARA	NS	CALLE HIDALGO
7000	SC	EB	CAMINO CAPISTRANO	FS	EL CAMINO REAL
7001	SC	NB	AVD VAQUERO	NS	VIA CASCADITA
7002	SC	NB	AVD VAQUERO	NS	CALLE VISTA TORITO
7003	SC	NB	AVD VAQUERO	OPP	CALLE ARCO
7004	SC	NB	AVD VAQUERO	NS	CALLE GUADALAJARA
7005	SC	NB	AVD VAQUERO	FS	CALLE VALLARTA
7006	SC	NB	AVD VAQUERO	NS	CAMINO DE LOS MARES
7007	SC	SB	AVD VAQUERO	FS	CAMINO DE LOS MARES
7008	SC	SB	AVD VAQUERO	OPP	CALLE VALLARTA
7009	SC	SB	AVD VAQUERO	OPP	CALLE GUADALAJARA
7010	SC	SB	AVD VAQUERO	NS	CALLE ARCO
7011	SC	SB	AVD VAQUERO	OPP	VIA MONTECITO
7012	SC	SB	AVD VAQUERO	OPP	VIA CASCADITA
7013	SC	EB	CAMINO DE LOS MARES	OPP	CAMINO EL MOLINA
7014	SC	EB	CAMINO DE LOS MARES	FS	ENT 654 OCEAN VIEW PLAZA
7015	SC	EB	CAMINO DE LOS MARES	NS	CALLE CAMPANA
7016	SC	WB	CAMINO DE LOS MARES	FS	MARBELLA
7017	SC	WB	CAMINO DE LOS MARES	FS	ENT 647 SAN CLEMENTE
7018	SC	WB	CAMINO DE LOS MARES	NS	CALLE AGUA
7019	SC	WB	CAMINO DE LOS MARES	NS	CAMINO EL MOLINO
7020	SC	NB	CAMINO DE ESTRELLA	FS	CAMINO MIRA COSTA
7021	SC	WB	CAMINO MIRA COSTA	FS	PASEO FLAMENCO
7022	SC	WB	CAMINO MIRA COSTA	NS	CAMINO DE ESTRELLA
7023	SC	NB	CALLE NEGOCIO	FS	CALLE AMANECER
7024	SC	NB	CALLE NEGOCIO	FS	ENT 931 NEGOCIO
7025	SC	NB	CALLE NEGOCIO	NS	CALLE TREPADORA
7026	SC	SB	CALLE TREPADORA	NS	CALLE AMANECER
7027	SC	SB	AVD LA PATA	FS	VIA CALLEJON
7028	SC	SB	AVD VISTA MONTANA	FS	CALLE DEL CERRO
7029	SC	SB	AVD VISTA MONTANA	FS	OPTIMA
7030	SC	SB	AVD VISTA MONTANA	OPP	PLAZA FLORA
7031	SC	SB	AVD VISTA MONTANA	OPP	CALLE CARACAS
7032	SC	SB	AVD VISTA MONTANA	FS	CALLE PASTADERO
7033	SC	WB	AVD VISTA MONTANA	OPP	SANTA CLARA
7034	SC	NB	AVD VISTA MONTANA	FS	ENT 260 SEA CREST
7035	SC	NB	AVD VISTA MONTANA	NS	CALLE AGUILA
7036	SC	NB	INTERIOR	@	FLAG POLE
7037	SJC	EB	CALLE ARROYO	FS	ENT 27412 ORTEGA COTTAGE
7038	SJC	WB	CALLE ARROYO	FS	LA NOVIA
7039	SJC	NB	CAMINO CAPISTRANO	OPP	AVD AEROPUERTO
7040	SJC	NB	CAMINO CAPISTRANO	NS	AVD PADRE

Bus Stop Maintenance

All Stop Locations

RFP 1-3408

Exhibit A

Attachment 2

OCTA_ID	CITY	DIR	STREET_OF_TRAVEL	LOC	CROSS_STREET
7041	SJC	NB	CAMINO CAPISTRANO	FS	DEL OBISPO
7042	SJC	NB	CAMINO CAPISTRANO	FS	ORTEGA
7043	SJC	NB	CAMINO CAPISTRANO	FS	ACJACHEMA
7044	SJC	NB	CAMINO CAPISTRANO	NS	LA ZANJA
7045	SJC	NB	CAMINO CAPISTRANO	FS	VIA LOS PAJAROS
7046	SJC	NB	CAMINO CAPISTRANO	FS	CALLE BONITA
7047	SJC	NB	CAMINO CAPISTRANO	FS	CALLE LORENZO
7048	SJC	NB	CAMINO CAPISTRANO	FS	CALLE CHUECA
7049	SJC	SB	CAMINO CAPISTRANO	FS	OSO
7050	SJC	SB	CAMINO CAPISTRANO	OPP	CALLE LORENZO
7051	SJC	SB	CAMINO CAPISTRANO	OPP	CALLE BONITA
7052	SJC	SB	CAMINO CAPISTRANO	OPP	VIA LOS PAJAROS
7053	SJC	SB	CAMINO CAPISTRANO	FS	LA ZANJA
7054	SJC	SB	CAMINO CAPISTRANO	OPP	ACJACHEMA
7055	SJC	SB	CAMINO CAPISTRANO	OPP	ORTEGA
7056	SJC	SB	CAMINO CAPISTRANO	VNS	DEL OBISPO
7057	SJC	SB	CAMINO CAPISTRANO	FS	DEL OBISPO
7058	SJC	SB	CAMINO CAPISTRANO	NS	AVD PADRE
7059	SJC	SB	CAMINO CAPISTRANO	FS	AVD AEROPUERTO
7060	SJC	NB	DEL OBISPO	FS	BLUE FIN
7061	SJC	NB	DEL OBISPO	NS	AVD PEDREGAL
7062	SJC	NB	DEL OBISPO	OPP	DANA MESA
7063	SJC	NB	DEL OBISPO	OPP	PASEO DE LA PAZ
7064	SJC	NB	DEL OBISPO	FS	ENT 32222 OCEAN
7065	SJC	NB	DEL OBISPO	FS	CALLE ASPERO
7066	SJC	NB	DEL OBISPO	OPP	CALLE REYNALDA
7067	SJC	NB	DEL OBISPO	FS	PASEO ADELANTO
7068	SJC	SB	DEL OBISPO	NS	PASEO ADELANTO
7069	SJC	SB	DEL OBISPO	FS	ALIPAZ
7070	SJC	SB	DEL OBISPO	FS	VIA BELARDES
7071	SJC	SB	DEL OBISPO	FS	CALLE ASPERO
7072	SJC	SB	DEL OBISPO	FS	PASEO DE LA PAZ
7073	SJC	SB	DEL OBISPO	FS	DANA MESA
7074	SJC	SB	DOHENY PARK	OPP	CAMINO CAPISTRANO
7075	SJC	EB	JUNIPERO SERRA	VFS	CAMINO CAPISTRANO
7076	SJC	EB	JUNIPERO SERRA	NS	RANCHO VIEJO
7077	SJC	WB	JUNIPERO SERRA	FS	RANCHO VIEJO
7078	SJC	WB	JUNIPERO SERRA	VNS	CAMINO CAPISTRANO
7079	SJC	NB	RANCHO VIEJO	FS	CALLE ARROYO
7080	SJC	NB	RANCHO VIEJO	NS	ORTEGA
7081	SJC	NB	RANCHO VIEJO	FS	ENT MARBELLA COUNTRY
7082	SJC	NB	RANCHO VIEJO	NS	ENT 30700 ENDEVCO
7083	SJC	NB	RANCHO VIEJO	NS	MISSION HILLS
7084	SJC	NB	RANCHO VIEJO	FS	VILLAGE
7085	SJC	SB	RANCHO VIEJO	OPP	VILLAGE
7086	SJC	SB	RANCHO VIEJO	OPP	MISSION HILLS

Bus Stop Maintenance

RFP 1-3408

All Stop Locations

Exhibit A

Attachment 2

OCTA_ID	CITY	DIR	STREET_OF_TRAVEL	LOC	CROSS_STREET
7087	SJC	SB	RANCHO VIEJO	OPP	ENT 30700 ENDEVCO
7088	SJC	SB	RANCHO VIEJO	NS	ENT MARBELLA PLAZA
7089	SJC	SB	RANCHO VIEJO	NS	PASEO ESPADA
7090	SJC	WB	STONEHILL	FS	CAMINO CAPISTRANO
7091	SJC	SB	EXIT	@	BOARDING AREA
7092	SJC	SB	INTERIOR	FS	JUNIPERO SERRA
7093	STN	NB	BEACH	FS	GARDEN GROVE
7094	STN	NB	BEACH	FS	STANFORD
7095	STN	NB	BEACH	NS	LAMPSON
7096	STN	NB	BEACH	FS	CATHERINE
7097	STN	NB	BEACH	FS	CHAPMAN
7098	STN	NB	BEACH	FS	BEVER
7099	STN	NB	BEACH	FS	ORANGEWOOD
7100	STN	NB	BEACH	OPP	RUTHANN
7101	STN	NB	BEACH	FS	KATELLA
7102	STN	NB	BEACH	NS	MAIN
7103	STN	NB	BEACH	FS	CERRITOS
7104	STN	NB	BEACH	FS	STARR
7105	STN	SB	BEACH	OPP	STARR
7106	STN	SB	BEACH	FS	CERRITOS
7107	STN	SB	BEACH	NS	PACIFIC
7108	STN	SB	BEACH	FS	KATELLA
7109	STN	SB	BEACH	@	RUTHANN
7110	STN	SB	BEACH	FS	ORANGEWOOD
7111	STN	SB	BEACH	OPP	BEAVER
7112	STN	SB	BEACH	FS	CHAPMAN
7113	STN	SB	BEACH	OPP	CATHERINE
7114	STN	SB	BEACH	FS	LAMPSON
7115	STN	SB	BEACH	FS	VILLAGE CENTER
7116	STN	EB	CHAPMAN	FS	BEACH
7117	STN	EB	CHAPMAN	NS	BRIARWOOD
7118	STN	EB	CHAPMAN	FS	DALE
7119	STN	WB	CHAPMAN	FS	BEACH
7120	STN	WB	CHAPMAN	FS	SANTA ROSALIA
7121	STN	WB	GARDEN GROVE	FS	COURT
7122	STN	EB	KATELLA	FS	KNOTT
7123	STN	EB	KATELLA	FS	BRADFORD
7124	STN	EB	KATELLA	FS	WESTERN
7125	STN	EB	KATELLA	OPP	DATE
7126	STN	EB	KATELLA	NS	CEDAR
7127	STN	EB	KATELLA	FS	BEACH
7128	STN	EB	KATELLA	OPP	BOATMAN
7129	STN	WB	KATELLA	FS	MAGONLIA
7130	STN	WB	KATELLA	FS	MACK
7131	STN	WB	KATELLA	FS	DALE
7132	STN	WB	KATELLA	FS	BOATMAN

Bus Stop Maintenance

RFP 1-3408

All Stop Locations

Exhibit A

Attachment 2

OCTA_ID	CITY	DIR	STREET_OF_TRAVEL	LOC	CROSS_STREET
7133	STN	WB	KATELLA	FS	BEACH
7134	STN	WB	KATELLA	FS	CEDAR
7135	STN	WB	KATELLA	FS	DATE
7136	STN	WB	KATELLA	FS	WESTERN
7137	STN	WB	KATELLA	OPP	BRADFORD
7138	STN	NB	KNOTT	FS	LONGFORD
7139	STN	NB	KNOTT	FS	KATELLA
7140	STN	NB	KNOTT	FS	KERMORE
7141	STN	NB	KNOTT	FS	CERRITOS
7142	STN	NB	MAGNOLIA	FS	PACIFIC
7143	ANA	NB	MAGNOLIA	FS	CERRITOS
7144	STN	SB	MAGNOLIA	FS	CERRITOS
7145	STN	SB	MAGNOLIA	NS	PACIFIC
7146	TUST	EB	17TH	FS	YORBA
7147	TUST	EB	17TH	FS	ENDERLE CENTER
7148	TUST	EB	17TH	NS	PROSPECT
7149	TUST	WB	17TH	FS	PROSPECT
7150	TUST	WB	17TH	FS	TREEHAVEN
7151	TUST	WB	17TH	NS	YORBA
7152	TUST	EB	1ST	OPP	TUSTIN
7153	TUST	EB	1ST	NS	PACIFIC
7154	TUST	EB	1ST	FS	B
7155	TUST	EB	1ST	FS	PROSPECT
7156	TUST	EB	1ST	FS	CENTENNIAL
7157	TUST	EB	1ST	FS	CENTENNIAL
7158	TUST	EB	1ST	FS	CENTENNIAL
7159	TUST	WB	1ST	FS	NEWPORT
7160	TUST	WB	1ST	OPP	CENTENNIAL
7161	TUST	WB	1ST	NS	HALL
7162	TUST	WB	1ST	FS	PROSPECT
7163	TUST	WB	1ST	FS	B
7164	TUST	WB	1ST	FS	YORBA
7165	TUST	WB	1ST	FS	TUSTIN
7166	TUST	EB	MAIN	FS	NEWPORT
7167	TUST	EB	BRYAN	OPP	CINDY
7168	TUST	EB	BRYAN	FS	RED HILL
7169	TUST	EB	BRYAN	FS	FARMINGTON
7170	TUST	EB	BRYAN	FS	BROWNING
7171	TUST	EB	BRYAN	FS	TUSTIN RANCH
7172	TUST	EB	BRYAN	FS	MARKET
7173	TUST	EB	BRYAN	NS	MYFORD
7174	TUST	WB	BRYAN	FS	JAMBOREE
7175	TUST	WB	BRYAN	FS	MYFORD
7176	TUST	WB	BRYAN	OPP	MARKET
7177	TUST	WB	BRYAN	FS	TUSTIN RANCH
7178	TUST	WB	BRYAN	NS	BROWNING

Bus Stop Maintenance

RFP 1-3408

All Stop Locations

Exhibit A

Attachment 2

OCTA_ID	CITY	DIR	STREET_OF_TRAVEL	LOC	CROSS_STREET
7179	TUST	WB	BRYAN	FS	FARMINGTON
7180	TUST	WB	BRYAN	FS	RED HILL
7181	TUST	WB	BRYAN	NS	CINDY
7182	TUST	WB	MAIN	FS	CENTENNIAL
7183	TUST	WB	MAIN	FS	PREBLE
7184	TUST	WB	MAIN	NS	PROSPECT
7185	TUST	WB	MAIN	NS	NEWPORT
7186	TUST	NB	CENTENNIAL	FS	MAIN
7187	TUST	NB	CENTENNIAL	NS	1ST
7188	TUST	EB	EDINGER	NS	DEL AMO
7189	TUST	EB	EDINGER	NS	RED HILL
7190	TUST	EB	EDINGER	OPP	JAMBOREE PLAZA
7191	TUST	WB	EDINGER	FS	ENT 3059 UNITED
7192	TUST	WB	EDINGER	FS	JAMBOREE PLAZA
7193	TUST	WB	EDINGER	FS	RED HILL
7194	TUST	WB	EDINGER	OPP	DEL AMO
7195	TUST	SB	EL CAMINO REAL	FS	MAIN
7196	TUST	SB	EL CAMINO REAL	FS	6TH
7197	TUST	EB	EL CAMINO REAL	OPP	ORANGE
7198	TUST	EB	EL CAMINO REAL	NS	RED HILL
7199	TUST	EB	EL CAMINO REAL	FS	TUSTIN RANCH
7200	TUST	EB	EL CAMINO REAL	FS	AUTO CENTER
7201	TUST	EB	EL CAMINO REAL	FS	WEST
7202	TUST	EB	EL CAMINO REAL	NS	EAST
7203	TUST	WB	EL CAMINO REAL	FS	EAST
7204	TUST	WB	EL CAMINO REAL	FS	WEST
7205	TUST	WB	EL CAMINO REAL	FS	AUTO CENTER
7206	TUST	WB	EL CAMINO REAL	FS	RED HILL
7207	TUST	WB	EL CAMINO REAL	VNS	ORANGE
7208	TUST	WB	EL CAMINO REAL	FS	ORANGE
7209	TUST	WB	EL CAMINO REAL	VFS	NEWPORT
7210	TUST	NB	EL CAMINO REAL	NS	6TH
7211	TUST	NB	EL CAMINO REAL	NS	MAIN
7212	TUST	NB	EL CAMINO REAL	FS	3RD
7213	TUST	NB	EL CAMINO REAL	NS	1ST
7214	TUST	EB	IRVINE	FS	YORBA
7215	TUST	EB	IRVINE	FS	A
7216	TUST	EB	IRVINE	NS	B
7217	TUST	EB	IRVINE	NS	PROSPECT
7218	TUST	EB	IRVINE	FS	NEWPORT
7219	TUST	EB	IRVINE	OPP	CHARLOMA
7220	TUST	EB	IRVINE	FS	BROWNING
7221	TUST	WB	IRVINE	NS	TUSTIN RANCH
7222	TUST	WB	IRVINE	FS	PROSPECT
7223	TUST	WB	IRVINE	FS	B
7224	TUST	WB	IRVINE	OPP	A

Bus Stop Maintenance

RFP 1-3408

All Stop Locations

Exhibit A

Attachment 2

OCTA_ID	CITY	DIR	STREET_OF_TRAVEL	LOC	CROSS_STREET
7225	TUST	SB	JAMBOREE	FS	IRVINE
7226	TUST	SB	JAMBOREE	FS	BRYAN
7227	TUST	EB	MCFADDEN	FS	PASADENA
7228	TUST	EB	MCFADDEN	NS	MYRTLE
7229	TUST	EB	MCFADDEN	NS	WALNUT
7230	TUST	WB	MCFADDEN	FS	NEWPORT
7231	TUST	WB	MCFADDEN	FS	PASADENA
7232	TUST	WB	MCFADDEN	FS	TUSTIN VILLAGE
7233	TUST	WB	MCFADDEN	FS	WILLIAMS
7234	TUST	WB	MCFADDEN	OPP	RITCHEY
7235	TUST	NB	NEWPORT	FS	WALNUT
7236	TUST	NB	NEWPORT	OPP	MCFADDEN
7237	TUST	NB	NEWPORT	FS	MITCHELL
7238	TUST	NB	NEWPORT	FS	EL CAMINO REAL
7239	TUST	NB	NEWPORT	FS	WALNUT
7240	TUST	NB	NEWPORT	NS	BRYAN
7241	TUST	NB	NEWPORT	FS	1ST
7242	TUST	NB	NEWPORT	OPP	HOLT
7243	TUST	NB	NEWPORT	FS	IRVINE
7244	TUST	NB	NEWPORT	NS	WASS
7245	TUST	SB	NEWPORT	NS	WARREN
7246	TUST	SB	NEWPORT	OPP	WASS
7247	TUST	SB	NEWPORT	FS	IRVINE
7248	TUST	SB	NEWPORT	NS	HOLT
7249	TUST	SB	NEWPORT	FS	1ST
7250	TUST	SB	NEWPORT	OPP	BRYAN
7251	TUST	SB	NEWPORT	NS	MAIN
7252	TUST	SB	NEWPORT	FS	MAIN
7253	TUST	SB	NEWPORT	FS	SIXTH
7254	TUST	SB	NEWPORT	FS	EL CAMINO REAL
7255	TUST	SB	NEWPORT	FS	MITCHELL
7256	TUST	EB	NISSON	FS	NEWPORT
7257	TUST	EB	NISSON	NS	DEL AMO
7258	TUST	EB	NISSON	FS	CHARLOMA
7259	TUST	NB	PROSPECT	FS	1ST
7260	TUST	NB	RED HILL	FS	BARRANCA
7261	TUST	NB	RED HILL	OPP	CARNEGIE
7262	TUST	NB	RED HILL	OPP	WARNER
7263	TUST	NB	RED HILL	OPP	BELL
7264	TUST	NB	RED HILL	FS	MOFFETT
7265	TUST	NB	RED HILL	OPP	SANTA FE
7266	TUST	NB	RED HILL	FS	EDINGER
7267	TUST	NB	RED HILL	FS	SYCAMORE
7268	TUST	NB	RED HILL	NS	WALNUT
7269	TUST	NB	RED HILL	FS	COOPERFIELD
7270	TUST	NB	RED HILL	FS	MITCHELL

Bus Stop Maintenance

RFP 1-3408

All Stop Locations

Exhibit A

Attachment 2

OCTA_ID	CITY	DIR	STREET_OF_TRAVEL	LOC	CROSS_STREET
7271	TUST	NB	RED HILL	NS	NISSON
7272	TUST	NB	RED HILL	FS	EL CAMINO REAL
7273	TUST	NB	RED HILL	NS	SAN JUAN
7274	TUST	NB	RED HILL	NS	LANCE
7275	TUST	SB	RED HILL	NS	LANCE
7276	TUST	SB	RED HILL	FS	SAN JUAN
7277	TUST	SB	RED HILL	NS	EL CAMINO REAL
7278	TUST	SB	RED HILL	FS	NISSON
7279	TUST	SB	RED HILL	FS	MITCHELL
7280	TUST	SB	RED HILL	OPP	COOPERFIELD
7281	TUST	SB	RED HILL	FS	WALNUT
7282	TUST	SB	RED HILL	FS	SYCAMORE
7283	TUST	SB	RED HILL	FS	EDINGER
7284	TUST	SB	RED HILL	FS	SANTA FE
7285	TUST	SB	RED HILL	NS	VALENCIA
7286	TUST	SB	RED HILL	FS	BELL
7287	TUST	NB	TUSTIN	FS	1ST
7288	TUST	NB	TUSTIN RANCH	FS	EL CAMINO REAL
7289	TUST	NB	TUSTIN RANCH	FS	BRYAN
7290	TUST	NB	TUSTIN RANCH	FS	HERITAGE
7291	TUST	SB	TUSTIN RANCH	FS	IRVINE
7292	TUST	SB	TUSTIN RANCH	FS	PARKCENTER
7293	TUST	SB	TUSTIN RANCH	FS	BRYAN
7294	TUST	EB	WALNUT	FS	NEWPORT
7295	TUST	EB	WALNUT	OPP	ATHERTON
7296	TUST	EB	WALNUT	FS	RED HILL
7297	TUST	EB	WALNUT	NS	OXFORD
7298	TUST	EB	WALNUT	OPP	BROWNING
7299	TUST	EB	WALNUT	FS	CHERRYWOOD
7300	TUST	EB	WALNUT	NS	FRANKLIN
7301	TUST	EB	WALNUT	FS	SINCLAIR
7302	TUST	EB	WALNUT	NS	MYFORD
7303	TUST	WB	WALNUT	FS	MYFORD
7304	TUST	WB	WALNUT	FS	FRANKLIN
7305	TUST	WB	WALNUT	FS	CHERRYWOOD
7306	TUST	WB	WALNUT	FS	BROWNING
7307	TUST	WB	WALNUT	OPP	OXFORD
7308	TUST	WB	WALNUT	NS	RED HILL
7309	TUST	WB	WALNUT	FS	ATHERTON
7310	TUST	WB	WALNUT	FS	NEWPORT
7311	TUST	WB	WARNER	OPP	PULLMAN
7312	TUST	NB	YORBA	FS	1ST
7313	TUST	SB	YORBA	FS	IRVINE
7314	VP	WB	COLLINS	FS	ROBERTO
7315	VP	WB	COLLINS	NS	WANDA
7316	VP	NB	WANDA	OPP	MONROE

Bus Stop Maintenance
All Stop Locations

RFP 1-3408
 Exhibit A
 Attachment 2

OCTA_ID	CITY	DIR	STREET_OF_TRAVEL	LOC	CROSS_STREET
7317	VP	NB	WANDA	FS	LINCOLN
7318	VP	NB	WANDA	NS	SANTIAGO
7319	VP	NB	SANTIAGO	OPP	BROOKSIDE
7320	VP	NB	SANTIAGO	FS	SERRANO
7321	WEST	NB	BEACH	FS	HEIL
7322	WEST	NB	BEACH	OPP	MACDONALD
7323	WEST	NB	BEACH	FS	MCFADDEN
7324	WEST	NB	BEACH	FS	BISHOP
7325	WEST	NB	BEACH	FS	BOLSA
7326	WEST	NB	BEACH	NS	MADISON
7327	WEST	NB	BEACH	FS	HAZARD
7328	WEST	NB	BEACH	FS	13TH
7329	WEST	NB	BEACH	FS	WESTMINSTER
7330	WEST	NB	BEACH	FS	21ST
7331	GG	NB	BEACH	FS	TRASK
7332	WEST	SB	BEACH	FS	TRASK
7333	WEST	SB	BEACH	FS	21ST
7334	WEST	SB	BEACH	FS	WESTMINSTER
7335	WEST	SB	BEACH	FS	13TH
7336	WEST	SB	BEACH	FS	HAZARD
7337	WEST	SB	BEACH	OPP	MADISON
7338	WEST	SB	BEACH	FS	BOLSA
7339	WEST	SB	BEACH	OPP	BISHOP
7340	WEST	SB	BEACH	FS	MCFADDEN
7341	WEST	EB	BOLSA	FS	GOLDEN WEST CIRCLE
7342	WEST	EB	BOLSA	FS	TEMPLE
7343	WEST	EB	BOLSA	NS	BEACH
7344	WEST	EB	BOLSA	FS	NEWLAND
7345	WEST	EB	BOLSA	FS	PURDY
7346	WEST	EB	BOLSA	FS	MAGNOLIA
7347	WEST	EB	BOLSA	NS	WESTSTATE
7348	WEST	EB	BOLSA	FS	MORAN
7349	WEST	EB	BOLSA	FS	BUSHARD
7350	WEST	EB	BOLSA	FS	ENT 9800 KENSINGTON
7351	WEST	EB	BOLSA	FS	BROOKHURST
7352	WEST	EB	BOLSA	OPP	HOPE
7353	WEST	EB	BOLSA	FS	WARD
7354	WEST	WB	BOLSA	FS	WARD
7355	WEST	WB	BOLSA	NS	HOPE
7356	WEST	WB	BOLSA	FS	BROOKHURST
7357	WEST	WB	BOLSA	VFS	BRANDON
7358	WEST	WB	BOLSA	VNS	BUSHARD
7359	WEST	WB	BOLSA	FS	BUSHARD
7360	WEST	WB	BOLSA	NS	MORAN
7361	WEST	WB	BOLSA	FS	CULTURAL COURT
7362	WEST	WB	BOLSA	FS	MAGNOLIA

Bus Stop Maintenance

RFP 1-3408

All Stop Locations

Exhibit A

Attachment 2

OCTA_ID	CITY	DIR	STREET_OF_TRAVEL	LOC	CROSS_STREET
7363	WEST	WB	BOLSA	OPP	TEMPLE
7364	WEST	WB	BOLSA	NS	CHESTNUT
7365	WEST	WB	BOLSA	FS	GOLDEN WEST
7366	WEST	WB	BOLSA	OPP	VICTORIA
7367	WEST	NB	BOLSA CHICA	FS	CHURCHILL
7368	WEST	NB	BOLSA CHICA	FS	ST JAMES
7369	WEST	NB	BOLSA CHICA	FS	WESTMINSTER
7370	WEST	NB	BOLSA CHICA	FS	LOYOLA
7371	WEST	NB	BOLSA CHICA	NS	DUNCANNON
7372	WEST	SB	BOLSA CHICA	NS	WESTMINSTER
7373	WEST	SB	BOLSA CHICA	OPP	ST JAMES
7374	WEST	SB	BOLSA CHICA	OPP	CHURCHILL
7375	WEST	NB	BROOKHURST	FS	MARGO
7376	WEST	NB	BROOKHURST	FS	MCFADDEN
7377	WEST	NB	BROOKHURST	OPP	BISHOP
7378	WEST	NB	BROOKHURST	FS	BOLSA
7379	WEST	NB	BROOKHURST	OPP	NEWCASTLE
7380	WEST	SB	BROOKHURST	FS	HAZARD
7381	WEST	SB	BROOKHURST	FS	NEWCASTLE
7382	WEST	SB	BROOKHURST	FS	BOLSA
7383	WEST	SB	BROOKHURST	NS	BISHOP
7384	WEST	SB	BROOKHURST	NS	MCFADDEN
7385	WEST	SB	BROOKHURST	FS	MARGO
7386	WEST	EB	EDINGER	FS	NEWLAND
7387	WEST	EB	EDINGER	FS	QUARTZ
7388	WEST	WB	EDINGER	FS	BUSHARD
7389	WEST	WB	EDINGER	OPP	SWEETLEAF
7390	WEST	WB	EDINGER	NS	PARLIAMENT
7391	WEST	WB	EDINGER	FS	MAGNOLIA
7392	WEST	WB	EDINGER	FS	QUARTZ
7393	WEST	WB	EDINGER	FS	NEWLAND
7394	WEST	NB	EDWARDS	OPP	MAR VISTA
7395	WEST	NB	EDWARDS	FS	ROYAL OAK
7396	WEST	NB	EDWARDS	FS	HOMER
7397	WEST	NB	EDWARDS	FS	WESTMINSTER
7398	WEST	NB	EDWARDS	NS	HUMBOLDT
7399	WEST	NB	EDWARDS	NS	TRASK
7400	WEST	NB	EDWARDS	FS	BESTEL
7401	WEST	SB	EDWARDS	NS	APACHE
7402	WEST	SB	EDWARDS	NS	KIOWA
7403	WEST	SB	EDWARDS	OPP	TRASK
7404	WEST	SB	EDWARDS	OPP	HUMBOLDT
7405	WEST	SB	EDWARDS	FS	WESTMINSTER
7406	WEST	SB	EDWARDS	OPP	HOMER
7407	WEST	EB	GARDEN GROVE	FS	ENT 5772 LOS ALISOS
7408	WEST	EB	GARDEN GROVE	FS	ENT 5772 LOS ALISOS

Bus Stop Maintenance

All Stop Locations

RFP 1-3408

Exhibit A

Attachment 2

OCTA_ID	CITY	DIR	STREET_OF_TRAVEL	LOC	CROSS_STREET
7409	WEST	EB	GARDEN GROVE	FS	MELANIE
7410	WEST	EB	GARDEN GROVE	FS	ENT 6152 ICE PALACE
7411	WEST	EB	GARDEN GROVE	FS	SENECA
7412	WEST	EB	GARDEN GROVE	FS	EDWARDS
7413	WEST	EB	GARDEN GROVE	FS	PALOMAR
7414	WEST	EB	GARDEN GROVE	VNS	GOLDEN WEST
7415	WEST	EB	GARDEN GROVE	OPP	EAGLE
7416	WEST	EB	GARDEN GROVE	OPP	WESTERN
7417	WEST	EB	GARDEN GROVE	FS	HOOVER
7418	WEST	EB	GARDEN GROVE	OPP	VILLAGE CENTER
7419	GG	WB	GARDEN GROVE	OPP	EDWARDS
7420	GG	WB	GARDEN GROVE	OPP	SENECA
7421	GG	WB	GARDEN GROVE	OPP	MELAINIE
7422	WEST	WB	GARDEN GROVE	OPP	ENT 5772 LOS ALISOS
7423	WEST	NB	GOLDEN WEST	FS	MCFADDEN
7424	WEST	NB	GOLDEN WEST	NS	GEORGETOWN
7425	WEST	NB	GOLDEN WEST	FS	BOLSA
7426	WEST	NB	GOLDEN WEST	FS	SOWELL
7427	WEST	NB	GOLDEN WEST	FS	HAZARD
7428	WEST	NB	GOLDEN WEST	FS	MAIN
7429	WEST	NB	GOLDEN WEST	FS	WESTMINSTER
7430	WEST	NB	GOLDEN WEST	FS	WYOMING
7431	WEST	NB	GOLDEN WEST	NS	21ST
7432	WEST	NB	GOLDEN WEST	FS	TRASK
7433	WEST	NB	GOLDEN WEST	FS	BESTEL
7434	WEST	NB	GOLDEN WEST	NS	LISA
7435	WEST	NB	GOLDEN WEST	NS	GARDEN GROVE
7436	WEST	SB	GOLDEN WEST	FS	GARDEN GROVE
7437	WEST	SB	GOLDEN WEST	FS	HOOD
7438	WEST	SB	GOLDEN WEST	FS	BESTEL
7439	WEST	SB	GOLDEN WEST	FS	TRASK
7440	WEST	SB	GOLDEN WEST	FS	WESTPARK
7441	WEST	SB	GOLDEN WEST	OPP	WYOMING
7442	WEST	SB	GOLDEN WEST	FS	WESTMINSTER
7443	WEST	SB	GOLDEN WEST	OPP	MAIN
7444	WEST	SB	GOLDEN WEST	OPP	MAPLE
7445	WEST	SB	GOLDEN WEST	OPP	HAZARD
7446	WEST	SB	GOLDEN WEST	FS	SOWELL
7447	WEST	NB	MAGNOLIA	FS	EDINGER
7448	WEST	NB	MAGNOLIA	FS	TRINI
7449	WEST	NB	MAGNOLIA	FS	MCFADDEN
7450	WEST	NB	MAGNOLIA	NS	BISHOP
7451	WEST	NB	MAGNOLIA	FS	BOLSA
7452	WEST	NB	MAGNOLIA	@	MADISON
7453	WEST	NB	MAGNOLIA	FS	HAZARD
7454	WEST	NB	MAGNOLIA	FS	JENNRICH

Bus Stop Maintenance

RFP 1-3408

All Stop Locations

Exhibit A

Attachment 2

OCTA_ID	CITY	DIR	STREET_OF_TRAVEL	LOC	CROSS_STREET
7455	WEST	SB	MAGNOLIA	FS	WESTMINSTER
7456	WEST	SB	MAGNOLIA	FS	MCCLURE
7457	WEST	SB	MAGNOLIA	FS	HAZARD
7458	WEST	SB	MAGNOLIA	NS	SINCLAIR
7459	WEST	SB	MAGNOLIA	NS	CHANNING
7460	WEST	SB	MAGNOLIA	FS	BOLSA
7461	WEST	SB	MAGNOLIA	FS	NATOMA
7462	WEST	SB	MAGNOLIA	FS	MCFADDEN
7463	WEST	SB	MAGNOLIA	NS	EMERALD
7464	WEST	SB	MAGNOLIA	FS	EDINGER
7465	WEST	SB	MAGNOLIA	FS	MINT
7466	WEST	SB	MAGNOLIA	OPP	FOXGLOVE
7467	WEST	SB	MAGNOLIA	NS	HEIL
7468	WEST	EB	MAIN	NS	LOCUST
7469	WEST	EB	MCFADDEN	FS	BEACH
7470	WEST	EB	MCFADDEN	FS	NEWLAND
7471	WEST	EB	MCFADDEN	FS	EDEN
7472	WEST	EB	MCFADDEN	NS	MAGNOLIA
7473	WEST	EB	MCFADDEN	NS	OAKCLIFF
7474	WEST	EB	MCFADDEN	FS	BUSHARD
7475	WEST	EB	MCFADDEN	FS	NARCISSUS
7476	WEST	EB	MCFADDEN	OPP	BELGRAVE
7477	WEST	EB	MCFADDEN	NS	BROOKHURST
7478	WEST	EB	MCFADDEN	OPP	NOTTINGHAM
7479	WEST	EB	MCFADDEN	OPP	YORKSHIRE
7480	WEST	WB	MCFADDEN	FS	WARD
7481	WEST	WB	MCFADDEN	FS	YORKSHIRE
7482	WEST	WB	MCFADDEN	NS	NOTTINGHAM
7483	WEST	WB	MCFADDEN	FS	BROOKHURST
7484	WEST	WB	MCFADDEN	FS	BELGRADE
7485	WEST	WB	MCFADDEN	NS	SWALLOW
7486	WEST	WB	MCFADDEN	FS	BUSHARD
7487	WEST	WB	MCFADDEN	FS	OAKCLIFF
7488	WEST	WB	MCFADDEN	NS	MAGNOLIA
7489	WEST	WB	MCFADDEN	FS	EDEN
7490	WEST	WB	MCFADDEN	FS	NEWLAND
7491	WEST	WB	MCFADDEN	FS	WILSON
7492	WEST	WB	MCFADDEN	FS	JACKSON
7493	WEST	WB	MCFADDEN	NS	BEACH
7494	WEST	WB	MCFADDEN	FS	VERMONT
7495	WEST	WB	MCFADDEN	FS	VASSAR
7496	WEST	NB	WARD	NS	BOLSA
7497	WEST	SB	WARD	FS	MCFADDEN
7498	WEST	SB	WARD	NS	FLORENCE
7499	WEST	EB	WESTMINSTER	FS	BOLSA CHICA
7500	WEST	EB	WESTMINSTER	FS	COLLEGE

Bus Stop Maintenance

RFP 1-3408

All Stop Locations

Exhibit A

Attachment 2

OCTA_ID	CITY	DIR	STREET_OF_TRAVEL	LOC	CROSS_STREET
7501	WEST	EB	WESTMINSTER	FS	UNIVERSITY
7502	WEST	EB	WESTMINSTER	FS	MILAN
7503	WEST	EB	WESTMINSTER	FS	RANCHO
7504	WEST	EB	WESTMINSTER	NS	SPRINGDALE
7505	WEST	EB	WESTMINSTER	FS	WILLOW
7506	WEST	EB	WESTMINSTER	NS	EDWARDS
7507	WEST	EB	WESTMINSTER	OPP	WESTMART
7508	WEST	EB	WESTMINSTER	NS	SUNSET
7509	WEST	EB	WESTMINSTER	FS	GOLDEN WEST
7510	WEST	EB	WESTMINSTER	OPP	CEDAR
7511	WEST	EB	WESTMINSTER	NS	OLIVE
7512	WEST	EB	WESTMINSTER	FS	HOOVER
7513	WEST	EB	WESTMINSTER	NS	CEDARWOOD
7514	WEST	EB	WESTMINSTER	FS	BEACH
7515	WEST	EB	WESTMINSTER	NS	ALL AMERICAN
7516	WEST	EB	WESTMINSTER	FS	NEWLAND
7517	WEST	EB	WESTMINSTER	FS	SHIRLEY
7518	WEST	EB	WESTMINSTER	FS	MAGNOLIA
7519	WEST	EB	WESTMINSTER	OPP	ATLANTIS
7520	WEST	EB	WESTMINSTER	NS	SWAN
7521	WEST	WB	WESTMINSTER	FS	NEWLAND
7522	WEST	WB	WESTMINSTER	FS	MONROE
7523	WEST	WB	WESTMINSTER	FS	BEACH
7524	WEST	WB	WESTMINSTER	NS	JASPERSON
7525	WEST	WB	WESTMINSTER	FS	ARIZONA
7526	WEST	WB	WESTMINSTER	NS	HOOVER
7527	WEST	WB	WESTMINSTER	FS	OLIVE
7528	WEST	WB	WESTMINSTER	NS	LOCUST
7529	WEST	WB	WESTMINSTER	FS	GOLDEN WEST
7530	WEST	WB	WESTMINSTER	FS	WESTMART
7531	WEST	WB	WESTMINSTER	FS	EDWARDS
7532	WEST	WB	WESTMINSTER	NS	WILLOW
7533	WEST	WB	WESTMINSTER	NS	BUSH
7534	WEST	WB	WESTMINSTER	FS	PEGG
7535	WEST	WB	WESTMINSTER	FS	HAMMON
7536	WEST	WB	WESTMINSTER	FS	MILAN
7537	WEST	WB	WESTMINSTER	FS	UNIVERSITY
7538	WEST	WB	WESTMINSTER	FS	COLLEGE
7539	WEST	WB	WESTMINSTER	NS	BOLSA CHICA
7540	WEST	NB	BUSHARD	FS	WESTWOOD
7541	WEST	NB	BUSHARD	NS	MCFADDEN
7542	WEST	NB	BUSHARD	FS	BISHOP
7543	WEST	SB	BUSHARD	FS	BOLSA
7544	WEST	SB	BUSHARD	FS	BISHOP
7545	WEST	SB	BUSHARD	NS	MCFADDEN
7546	WEST	SB	BUSHARD	FS	STINSON

Bus Stop Maintenance

RFP 1-3408

All Stop Locations

Exhibit A

Attachment 2

OCTA_ID	CITY	DIR	STREET_OF_TRAVEL	LOC	CROSS_STREET
7547	WEST	EB	HAZARD	FS	COLONIAL
7548	WEST	EB	HAZARD	FS	MAGNOLIA
7549	WEST	EB	HAZARD	FS	SNOW
7550	WEST	EB	HAZARD	FS	BUSHARD
7551	WEST	EB	HAZARD	OPP	KERRY
7552	WEST	EB	HAZARD	FS	BROOKHURST
7553	WEST	EB	HAZARD	OPP	DEANANN
7554	WEST	EB	HAZARD	NS	WARD
7555	WEST	WB	HAZARD	FS	BUSHARD
7556	WEST	WB	HAZARD	FS	MORAN
7557	WEST	WB	HAZARD	FS	MAGNOLIA
7558	WEST	WB	HAZARD	FS	PURDY
7559	WEST	EB	INTERIOR	@	JC PENNY
7560	WEST	SB	INTERIOR	FS	MALL RING
7561	WHIT	NB	FIRST	FS	LETTINGWELL
7562	WHIT	NB	FIRST	FS	LISCO
7563	WHIT	NB	FIRST	NS	WHITTIER
7564	WHIT	SB	FIRST	FS	WHITTIER
7565	WHIT	SB	FIRST	FS	LISCO
7566	WHIT	SB	FIRST	OPP	RUSHFORD
7567	WHIT	EB	LETTINGWELL	FS	FIRST
7568	WHIT	EB	LETTINGWELL	FS	TIGRINA
7569	WHIT	EB	LETTINGWELL	OPP	VALLEY HOME
7570	WHIT	WB	LETTINGWELL	NS	JORDAN
7571	WHIT	EB	WHITTIER	FS	SANTA GERTRUDES
7572	WHIT	EB	WHITTIER	FS	VIRGINIA
7573	WHIT	EB	WHITTIER	FS	FIRST
7574	WHIT	EB	WHITTIER	FS	JORDAN
7575	WHIT	EB	WHITTIER	NS	VALLEY HOME
7576	WHIT	WB	WHITTIER	FS	VALLEY HOME
7577	WHIT	WB	WHITTIER	NS	POUNDS
7578	WHIT	WB	WHITTIER	OPP	FIRST
7579	WHIT	WB	WHITTIER	OPP	VIRGINIA
7580	WHIT	WB	WHITTIER	NS	RUSSELL
7581	WHIT	WB	WHITTIER	FS	SANTA GERTRUDES WEST
7582	WHIT	NB	INTERIOR	NS	WHITTWOOD
7583	WHIT	EB	WHITTWOOD	FS	INTERIOR
7584	WHIT	EB	WHITTWOOD	OPP	SANTA GERTRUDES WEST
7585	YL	NB	FAIRMONT	FS	YORBA LINDA
7586	YL	NB	FAIRMONT	OPP	MONTEANO
7587	YL	NB	FAIRMONT	FS	CAMAROSA
7588	YL	NB	FAIRMONT	NS	AVD DEL REY
7589	YL	SB	FAIRMONT	FS	EXIT NORTH ORANGE COUNTY
7590	YL	SB	FAIRMONT	OPP	CAMAROSA
7591	YL	SB	FAIRMONT	FS	MONTEANO
7592	YL	SB	FAIRMONT	VNS	YORBA LINDA

Bus Stop Maintenance

RFP 1-3408

All Stop Locations

Exhibit A

Attachment 2

OCTA_ID	CITY	DIR	STREET_OF_TRAVEL	LOC	CROSS_STREET
7593	YL	EB	YORBA LINDA	FS	JEFFERSON
7594	YL	EB	YORBA LINDA	FS	VAN BUREN
7595	YL	EB	YORBA LINDA	OPP	VALLEY VIEW
7596	YL	EB	YORBA LINDA	NS	CASA LOMA
7597	YL	EB	YORBA LINDA	NS	EUREKA
7598	YL	EB	YORBA LINDA	FS	MOUNTAIN VIEW
7599	YL	EB	YORBA LINDA	NS	IMPERIAL
7600	YL	EB	YORBA LINDA	FS	LAKEVIEW
7601	YL	EB	YORBA LINDA	FS	AVOCADO
7602	YL	EB	YORBA LINDA	FS	OHIO
7603	YL	EB	YORBA LINDA	FS	CLUB TERRACE
7604	YL	WB	YORBA LINDA	OPP	KELLOGG
7605	YL	WB	YORBA LINDA	FS	PALM
7606	YL	WB	YORBA LINDA	FS	OHIO
7607	YL	WB	YORBA LINDA	FS	AVOCADO
7608	YL	WB	YORBA LINDA	NS	LAKEVIEW
7609	YL	WB	YORBA LINDA	FS	IMPERIAL
7610	YL	WB	YORBA LINDA	NS	EUREKA
7611	YL	WB	YORBA LINDA	FS	CASA LOMA
7612	YL	WB	YORBA LINDA	FS	VALLEY VIEW
7613	YL	WB	YORBA LINDA	FS	VAN BUREN
7614	YL	WB	YORBA LINDA	NS	PROSPECT
7615	YL	WB	YORBA LINDA	FS	ROSE
7650	SA	NB	EUCLID	FS	LENHARDT
7651	ANA	NB	LAKEVIEW	FS	LA PALMA
7652	ANA	NB	LAKEVIEW	OPP	MIRALOMA
7653	ANA	NB	LAKEVIEW	NS	ORANGETHORPE
7654	PLAC	SB	LAKEVIEW	FS	MARIPOSA
7655	ANA	SB	LAKEVIEW	NS	ORANGETHORPE
7656	PLAC	SB	LAKEVIEW	OPP	EISENHOWER
7657	YL	NB	IMPERIAL	NS	MAIN
7658	YL	NB	LAKEVIEW	OPP	MARIPOSA
7659	YL	NB	LAKEVIEW	FS	VIA ARBOLEDA
7660	YL	NB	LAKEVIEW	FS	FLORA
7661	YL	SB	LAKEVIEW	NS	YORBA LINDA
7662	YL	SB	LAKEVIEW	FS	LAUREL VIEW
7663	YL	SB	LAKEVIEW	FS	BUENA VISTA
7664	YL	EB	LEMON	FS	MAIN
7665	DP	SB	PACIFIC COAST	OPP	CAMINO CAPISTRANO
7666	CM	WB	17TH	FS	PLACENTIA
7667	CM	WB	17TH	NS	MONROVIA
7668	CM	NB	MONROVIA	FS	17TH
7669	IRV	EB	TRABUCO	FS	WOODBURY
7670	OR	EB	CHAPMAN	NS	ANITA
7671	OR	WB	CHAPMAN	OPP	ANITA
7672	SC	SB	EL CAMINO REAL	OPP	CAMINO CAPISTRANO

Bus Stop Maintenance

All Stop Locations

RFP 1-3408

Exhibit A

Attachment 2

OCTA_ID	CITY	DIR	STREET_OF_TRAVEL	LOC	CROSS_STREET
7673	LA	SB	TERMINAL	@	TERMINAL 31
7674	MV	SB	NO STREET	OPP	TEST STREEET3
7675	GG	SB	HASTER	OPP	ALLARD
7676	LH	NB	BEACH	VNS	IMPERIAL
7677	ANA	EB	INTERIOR	FS	HOTEL
7678	IRV	EB	UNIVERSITY	FS	MESA
7679	GG	SB	SPRINGDALE	FS	VANGUARD
7680	HB	EB	YORKTOWN	NS	DELAWARE
7681	HB	WB	YORKTOWN	FS	BEACH
7682	SA	NB	MAIN	NS	MACARTHUR
7683	SA	SB	HUTTON CENTRE	FS	MACARTHUR
7684	SA	NB	PLAZA	FS	SUNFLOWER
7685	SA	WB	SANDPOINTE	FS	HUTTON CENTRE
7686	SA	EB	FRUIT	NS	GRAND
7687	SA	NB	FULLER	NS	SANTA ANA
7688	SA	SB	FULLER	FS	SANTA ANA
7689	BP	EB	COMMONWEALTH	FS	AUTO CENTER
7690	FULL	WB	CHAPMAN	FS	COMMONWEALTH
7691	HB	NB	MAIN	NS	CLAY
7692	FULL	EB	NUTWOOD	NS	COMMONWEALTH
7693	LF	NB	LAKE FOREST	FS	RANCHO
7694	LF	NB	LAKE FOREST	FS	TOWNE CENTRE
7695	TUST	SB	ENDERLE CENTER	NS	VANDENBURG
7696	TUST	NB	NEWPORT	OPP	MYRTLE
7697	CM	NB	AVE OF THE ARTS	FS	ANTON
7698	SA	SB	PULLMAN	VFS	DYER
7699	FULL	WB	MALVERN	VNS	GILBERT
7700	TUST	NB	ENDERLE CENTER	FS	VANDENBURG
7701	HB	WB	YORKTOWN	FS	DELAWARE
7702	LB	NB	NORWALK	NS	WARDLOW
7703	FULL	WB	CHAPMAN	OPP	CLARKE
7704	WEST	NB	INTERIOR	@	ROBINSONS-MAY
7705	WEST	SB	MALL RING	NS	MAR VISTA
7706	LH	SB	EUCLID	NS	OLIVE
7707	NB	WB	SAN MIGUEL	FS	SAN JOAQUIN HILLS
7708	NB	EB	SAN MIGUEL	FS	MACARTHUR
7709	CM	SB	BRISTOL	VFS	BAKER
7710	NB	WB	SAN JOAQUIN HILLS	FS	SAN MIGUEL
7711	ANA	NB	EAST	FS	TURIN
7712	IRV	NB	HARVARD	FS	ALTON
7713	IRV	NB	HARVARD	FS	SAN JUAN
7714	IRV	NB	HARVARD	FS	BARRANCA
7715	IRV	NB	HARVARD	FS	WARNER
7716	IRV	NB	HARVARD	FS	PASEO WESTPARK
7717	IRV	NB	HARVARD	FS	IRVINE CENTER
7718	IRV	NB	HARVARD	FS	POPLAR

Bus Stop Maintenance

RFP 1-3408

All Stop Locations

Exhibit A

Attachment 2

OCTA_ID	CITY	DIR	STREET_OF_TRAVEL	LOC	CROSS_STREET
7719	IRV	SB	HARVARD	FS	POPLAR
7720	TUST	SB	HARVARD	FS	EDINGER
7721	TUST	SB	HARVARD	FS	MOFFETT
7722	IRV	SB	HARVARD	FS	WARNER
7723	IRV	SB	HARVARD	NS	BARRANCA
7724	IRV	SB	HARVARD	OPP	SAN JUAN
7725	BP	EB	ARTESIA	NS	STANTON
7726	BP	EB	ARTESIA	FS	INDIANA
7727	BP	WB	ARTESIA	FS	DALE
7728	BP	WB	ARTESIA	NS	INDIANA
7729	BP	WB	ARTESIA	NS	STANTON
7730	BP	NB	DALE	FS	WHITAKER
7731	BP	NB	DALE	NS	COMMONWEALTH
7732	BP	SB	DALE	FS	ARTESIA
7733	BP	SB	DALE	FS	COMMONWEALTH
7734	BP	SB	DALE	NS	WHITAKER
7735	BP	SB	DALE	OPP	FLOWER
7736	BP	NB	LA MIRADA BLVD	FS	BEACH
7737	BP	WB	AUTO CENTER	FS	MAXWELL
7738	FULL	NB	DALE	FS	FLOWER
7739	LM	NB	ADELFA	FS	SANTA GERTRUDES
7740	LM	NB	ADELFA	FS	ASHGROVE
7741	LM	NB	LA MIRADA	FS	ALONDRA
7742	LM	SB	LA MIRADA	FS	ROSECRANS
7743	LM	SB	LA MIRADA	FS	EXCELSIOR
7744	LM	SB	LA MIRADA	FS	OCASO
7745	LM	SB	LA MIRADA	NS	ALONDRA
7746	LM	WB	ROSECRANS	NS	JALON
7747	CM	EB	BAKER	NS	BRISTOL
7748	CM	EB	BAKER	OPP	ENTERPRISE
7749	CM	NB	BEAR	FS	LIFESTYLES
7750	CM	NB	BEAR	OPP	SOUTH COAST
7751	CM	SB	BEAR	FS	SOUTH COAST
7752	CM	EB	PAULARINO	FS	BEAR
7753	CM	EB	PAULARINO	OPP	YELLOWSTONE
7754	CM	WB	PAULARINO	FS	RED HILL
7755	CM	WB	PAULARINO	NS	MANISTEE
7756	CM	WB	PAULARINO	FS	BRISTOL
7757	CM	WB	PAULARINO	NS	BEAR
7758	NB	EB	SAN JOAQUIN HILLS	FS	SANTA CRUZ
7759	NB	EB	SAN JOAQUIN HILLS	NS	SANTA ROSA
7760	NB	WB	SAN JOAQUIN HILLS	FS	BIG CANYON
7761	IRV	EB	IRVINE CENTER	OPP	CHARTER
7762	IRV	NB	SAND CANYON	FS	ALTON
7763	IRV	NB	SAND CANYON	FS	HOSPITAL
7764	IRV	SB	SAND CANYON	OPP	HOSPITAL

Bus Stop Maintenance

RFP 1-3408

All Stop Locations

Exhibit A

Attachment 2

OCTA_ID	CITY	DIR	STREET_OF_TRAVEL	LOC	CROSS_STREET
7765	IRV	EB	MICHELSON	FS	BIXBY
7766	LF	NB	DIMENSION	FS	LAKE FOREST
7767	LF	NB	DIMENSION	FS	CANADA
7768	LF	SB	DIMENSION	FS	COMMERCENTER
7769	LF	SB	DIMENSION	FS	CANADA
7770	SA	NB	BEAR	FS	SUNFLOWER
7771	SA	NB	BEAR	OPP	WAKEHAM
7772	SA	SB	BEAR	FS	MACARTHUR
7773	CM	NB	BEAR	FS	BAKER
7774	CM	NB	BEAR	FS	PAULARINO
7775	SA	SB	BEAR	NS	WAKEHAM
7776	CM	SB	BEAR	NS	PAULARINO
7777	TUST	EB	EDINGER	FS	PARKWAY
7778	SC	SB	EL CAMINO REAL	NS	AVD MENDOCINO
7779	BP	NB	BOTRYOIDES	NS	ARTESIA
7780	LKWD	WB	DEL AMO	FS	PIONEER
7781	HG	NB	NORWALK	FS	CARSON
7782	FULL	WB	SANTA FE	NS	LEMON
7783	NB	NB	AVOCADO	OPP	SAN NICOLAS
7784	TUST	WB	TMS	@	DOCK 1
7785	LN	SB	NIGUEL	OPP	BEACON HILL
7786	LN	SB	NIGUEL	FS	RIDGEWAY
7787	SA	SB	MAIN	FS	MCFADDEN
7788	SA	EB	FRUIT	NS	TUSTIN
7789	SA	EB	FRUIT	NS	TUSTIN
7790	SA	EB	FRUIT	NS	TUSTIN
7791	SA	EB	MCFADDEN	FS	MAIN
7792	SA	WB	MCFADDEN	FS	ORANGE
7793	HG	EB	CARSON	VNS	NORWALK
7794	SA	EB	MCFADDEN	NS	BIRCH
7795	SA	EB	MCFADDEN	FS	ORANGE
7796	OR	NB	BATAVIA	FS	TAFT
7797	OR	NB	BATAVIA	OPP	GROVE
7798	OR	NB	BATAVIA	NS	SOUTHERN
7799	OR	NB	BATAVIA	NS	FLETCHER
7800	OR	NB	BATAVIA	OPP	GREEN RIVER
7801	OR	SB	BATAVIA	FS	GREEN RIVER
7802	OR	SB	BATAVIA	FS	FLETCHER
7803	OR	SB	BATAVIA	OPP	CULLY
7804	OR	SB	BATAVIA	OPP	GROVE
7805	LF	NB	ALTON	FS	COMMERCENTRE
7806	LF	NB	ALTON	FS	BAFFIN BAY
7807	LF	NB	ALTON	FS	"G"
7808	LF	NB	ALTON	FS	DIMENSION
7809	LF	SB	ALTON	FS	DIMENSION
7810	LF	SB	ALTON	FS	"H"

Bus Stop Maintenance

All Stop Locations

RFP 1-3408

Exhibit A

Attachment 2

OCTA_ID	CITY	DIR	STREET_OF_TRAVEL	LOC	CROSS_STREET
7811	LF	SB	ALTON	FS	"I"
7812	LF	SB	ALTON	OPP	COMMERCENTRE
7813	ANA	EB	KATELLA	FS	SPORTSTOWN
7814	ANA	WB	KATELLA	NS	STADIUM CROSSING
7815	DP	WB	STONEHILL	OPP	BLUE LANTERN
7816	TUST	WB	IRVINE	FS	JAMBOREE
7817	TUST	WB	IRVINE	FS	ROBINSON
7818	TUST	EB	IRVINE	FS	TUSTIN RANCH
7819	TUST	EB	IRVINE	FS	ROBINSON
7820	IRV	EB	IRVINE	FS	MARKET PLACE
7821	IRV	EB	IRVINE	FS	CENTRAL PARK
7822	IRV	WB	IRVINE	FS	CENTRAL PARK
7823	IRV	WB	IRVINE	FS	MARKET PLACE
7824	LAGH	EB	LAKE FOREST	NS	TRITON
7825	IRV	NB	JEFFREY	FS	ROOSEVELT
7826	IRV	EB	TRABUCO	FS	JEFFREY
7827	IRV	EB	TRABUCO	FS	C
7828	IRV	EB	TRABUCO	FS	SAND CANYON
7829	IRV	SB	SAND CANYON	FS	TRABUCO
7830	IRV	SB	SAND CANYON	FS	ROOSEVELT
7831	IRV	NB	SAND CANYON	FS	B
7832	IRV	NB	SAND CANYON	FS	ROOEVELT
7833	BP	EB	AUTO CENTER	FS	BEACH
7834	BP	EB	AUTO CENTER	FS	STANTON
7835	BP	EB	AUTO CENTER	OPP	10TH
7836	BP	EB	AUTO CENTER	OPP	MAXWELL
7837	BP	WB	AUTO CENTER	FS	10TH
7838	BP	WB	AUTO CENTER	FS	STANTON
7839	TUST	WB	WARNER	FS	RED HILL
7864	SA	NB	COLLEGE	FS	WASHINGTON
7865	SA	SB	BRISTOL	NS	WASHINGTON
7866	SA	WB	WASHINGTON	OPP	PACIFIC
7867	HB	WB	YORKTOWN	VNS	GOLDEN WEST
7868	ANA	NB	SUNKIST	NS	CYPRIEN
7869	ANA	SB	SUNKIST	NS	SYCAMORE
7870	ANA	NB	BLUE GUM	FS	LA PALMA
7871	ANA	NB	BLUE GUM	FS	CORONADO
7872	ANA	NB	BLUE GUM	NS	MIRALOMA
7873	ANA	SB	BLUE GUM	FS	MIRALOMA
7874	ANA	SB	BLUE GUM	FS	CORONADO
7875	ANA	SB	BLUE GUM	NS	LA PALMA
7876	FULL	SB	PLACENTIA	FS	CHAPMAN
7877	FULL	SB	PLACENTIA	FS	FENDER
7878	FULL	SB	PLACENTIA	NS	KIMBERLEY
7879	FULL	EB	YORBA LINDA	FS	CAMPUS
7880	FULL	WB	YORBA LINDA	NS	DEERPARK

Bus Stop Maintenance

All Stop Locations

RFP 1-3408

Exhibit A

Attachment 2

OCTA_ID	CITY	DIR	STREET_OF_TRAVEL	LOC	CROSS_STREET
7881	PLAC	EB	ORANGETHORPE	FS	PLACENTIA
7882	PLAC	NB	PLACENTIA	FS	ORANGETHORPE
7883	PLAC	NB	PLACENTIA	NS	KIMBERELY
7884	PLAC	NB	PLACENTIA	FS	CROWTHER
7885	PLAC	NB	PLACENTIA	OPP	FENDER
7886	PLAC	NB	PLACENTIA	FS	SANTA FE
7887	LA	EB	6TH	FS	SPRING
7888	LA	SB	FLOWER	FS	3RD
7889	TUST	WB	TMS	@	DOCK 2
7890	PLAC	NB	BRADFORD	OPP	PRIMROSE
7891	PLAC	NB	BRADFORD	OPP	QUARTZ
7892	FULL	SB	BRADFORD	FS	QUARTZ
7893	PLAC	SB	BRADFORD	FS	PRIMROSE
7894	ANA	SB	MILLER	FS	ORANGETHORPE
7895	IRV	SB	SAND CANYON	FS	BARRANCA
7896	TUST	NB	RED HILL	FS	PARKWAY
7897	CM	EB	ANTON	VFS	SAKIOKA
7898	CM	WB	ANTON	VNS	SAKIOKA
7899	CM	SB	HYLAND	FS	MACARTHUR
7900	CM	EB	SUNFLOWER	FS	HYLAND
7901	HB	WB	TALBERT	VNS	BEACH
7902	FV	WB	SOUTHPARK	FS	NEWHOPE
7903	SA	WB	MACARTHUR	FS	RAITT
7904	ANA	EB	MIRALOMA	FS	GROVE
7905	ANA	WB	MIRALOMA	OPP	GROVE
7906	TUST	WB	TMS	@	DOCK 3
7907	MV	NB	MAQUINA	FS	ACERO
7908	MV	SB	MAQUINA	NS	ACERO
7909	MV	NB	PALA	NS	ALAMBRE
7910	MV	WB	MADERO	OPP	PALA
7911	MV	WB	MADERO	FS	ENT 23456 HIGHPARK
7912	MV	EB	MADERO	FS	ENT 23455 VOCATIONAL
7913	MV	WB	MADERO	FS	ENT 23312 MISSION VIEJO
7914	LF	SB	LOS ALISOS	FS	MADERO
7915	FULL	NB	STATE COLLEGE	NS	BASTANCHURY
7916	FULL	NB	STATE COLLEGE	FS	ROLLING HILLS
7917	FULL	NB	STATE COLLEGE	FS	LARK ELLEN
7918	BREA	NB	STATE COLLEGE	VNS	IMPERIAL
7919	BREA	SB	STATE COLLEGE	FS	IMPERIAL
7920	BREA	SB	STATE COLLEGE	FS	ELM
7921	FULL	SB	STATE COLLEGE	NS	ROLLING HILLS
7922	BP	EB	ARTESIA	OPP	INDUSTRY
7923	BP	EB	ARTESIA	FS	ALTURA
7924	BP	EB	ARTESIA	NS	KNOTT
7925	BP	NB	VALLEY VIEW	NS	ARTESIA
7926	CERR	SB	VALLEY VIEW	FS	ARTESIA

Bus Stop Maintenance

RFP 1-3408

All Stop Locations

Exhibit A

Attachment 2

OCTA_ID	CITY	DIR	STREET_OF_TRAVEL	LOC	CROSS_STREET
7927	LM	WB	ARTESIA	FS	FIRESTONE
7928	LM	WB	ARTESIA	OPP	ALTURA
7929	LM	WB	ARTESIA	NS	INDUSTRY
7930	LP	SB	VALLEY VIEW	FS	183RD
7931	OR	SB	MANCHESTER	NS	CITY
7932	BP	EB	CABALLERO	OPP	DESCANSO
7933	BP	NB	REGIO	FS	CABALLERO
7934	BP	WB	CABALLERO	FS	REGIO
7935	BP	EB	ALTURA	FS	REGIO
7936	BP	SB	ALTURA	FS	ARTESIA
7937	OR	WB	STRUCK	FS	MAIN
7938	LKWD	WB	DEL AMO	VFS	PIONEER
7939	MV	NB	LOS ALISOS	FS	JERONIMO
7940	MV	NB	LOS ALISOS	NS	MADERO
7941	MV	EB	MADERO	NS	ENT 23351 HOLT INC
7942	MV	EB	MADERO	NS	PALA
7943	MV	SB	PALA	OPP	MAQUINA
7944	SC	WB	AVD PRESIDIO	FS	ENT 105 CASA DE SENIORS
7945	DP	EB	SELVA	NS	CAPE COVE
7946	OR	EB	OTC	NS	ATCHISON
7947	OR	WB	MAPLE	OPP	ATCHISON
7948	OR	WB	MAPLE	FS	CYPRESS
7949	FULL	EB	MALVERN	OPP	TARGET
7950	BREA	EB	IMPERIAL	NS	STATE COLLEGE
7951	FULL	EB	IMPERIAL	FS	ASSOCIATED
7952	BREA	EB	IMPERIAL	FS	PLACENTIA
7953	BREA	EB	IMPERIAL	FS	SHOPPING CENTER
7954	BREA	EB	IMPERIAL	FS	KRAEMER
7955	BREA	EB	IMPERIAL	NS	SATURN
7956	BREA	EB	IMPERIAL	FS	VALENCIA
7957	PLAC	SB	IMPERIAL	FS	ROSE
7958	YL	SB	IMPERIAL	FS	VALLEY VIEW
7959	YL	SB	IMPERIAL	NS	CASA LOMA
7960	YL	SB	IMPERIAL	FS	EUREKA
7961	YL	NB	IMPERIAL	OPP	LEMON
7962	YL	NB	IMPERIAL	NS	EUREKA
7963	YL	NB	IMPERIAL	FS	CASA LOMA
7964	YL	NB	IMPERIAL	FS	VALLEY VIEW
7965	YL	NB	IMPERIAL	FS	BASTANCHURY
7966	YL	NB	IMPERIAL	FS	PROSPECT
7967	PLAC	NB	IMPERIAL	FS	ROSE
7968	BREA	WB	IMPERIAL	FS	VALENCIA
7969	BREA	WB	IMPERIAL	FS	SATURN
7970	BREA	WB	IMPERIAL	FS	KRAEMER
7971	BREA	WB	IMPERIAL	FS	SHOPPING CENTER
7972	BREA	WB	IMPERIAL	FS	CASTLEGATE

Bus Stop Maintenance

All Stop Locations

RFP 1-3408

Exhibit A

Attachment 2

OCTA_ID	CITY	DIR	STREET_OF_TRAVEL	LOC	CROSS_STREET
7973	YL	SB	IMPERIAL	FS	PROSPECT
7974	YL	SB	IMPERIAL	NS	BASTANCHURY
7975	LA	SB	LOS ANGELES	NS	8TH
7976	NB	EB	OCEAN FRONT	OPP	PALM
7977	NB	EB	OCEAN FRONT	OPP	PALM
7978	NB	EB	OCEAN FRONT	OPP	PALM
7979	OC	EB	HAZARD	NS	MONROE
7980	OC	EB	HAZARD	FS	NEWLAND
7981	OC	EB	HAZARD	FS	PURDY
7982	WEST	EB	HAZARD	FS	GOLDEN WEST
7983	FULL	NB	HARBOR	NS	COMMONWEALTH
7984	FULL	SB	BERKELEY	FS	WEST VALLEY VIEW
7985	FULL	EB	BERKELEY	NS	HARBOR
7986	FULL	NB	BREA	FS	ASHBURN
7987	FULL	SB	BREA	OPP	ASHBURN
7988	FULL	NB	LEMON	FS	CHAPMAN
7989	FULL	NB	LEMON	FS	FULLERTON COLLEGE
7990	FULL	EB	BERKELEY	FS	HARBOR
7991	FULL	SB	LEMON	OPP	GROVE
7992	IRV	NB	VON KARMAN	VNS	BARRANCA
7993	LF	WB	PORTOLA	FS	MARKET
7994	SA	WB	SAINT ANDREW	FS	LYON
7995	SA	WB	SAINT ANDREW	VNS	GRAND
7996	SA	EB	SAINT ANDREW	FS	GRAND
7997	SA	NB	LYON	FS	SAINT ANDREW
7998	SA	SB	SANTIAGO	NS	6TH
7999	SA	NB	THE DEPOT	@	DOCK 11
8000	SA	NB	THE DEPOT	@	DOCK 12
8001	SA	NB	THE DEPOT	@	DOCK 13
8002	WEST	EB	HAZARD	FS	CHESTNUT
8003	WEST	EB	HAZARD	NS	HOOVER
8004	WEST	EB	HAZARD	OPP	CEDARWOOD
8005	WEST	EB	HAZARD	FS	BEACH
8006	GG	EB	HAZARD	OPP	KERRY
8007	GG	EB	HAZARD	FS	WARD
8008	SA	EB	HAZARD	OPP	WEST
8009	SA	EB	5TH	FS	HARBOR
8011	SA	EB	CIVIC CENTER	FS	FAIRVIEW
8012	SA	EB	CIVIC CENTER	FS	HAWLEY
8013	SA	EB	CIVIC CENTER	FS	RAITT
8014	SA	EB	CIVIC CENTER	FS	BOYD
8015	SA	EB	CIVIC CENTER	NS	MAIN
8016	SA	EB	CIVIC CENTER	FS	FRENCH
8017	SA	EB	CIVIC CENTER	FS	GARFIELD
8018	SA	SB	SANTIAGO	FS	CIVIC CENTER
8019	SA	SB	MCCLAY	NS	GRAND

Bus Stop Maintenance

All Stop Locations

RFP 1-3408

Exhibit A

Attachment 2

OCTA_ID	CITY	DIR	STREET_OF_TRAVEL	LOC	CROSS_STREET
8020	SA	WB	CIVIC CENTER	FS	SANTIAGO
8021	SA	WB	CIVIC CENTER	FS	GARFIELD
8022	SA	WB	CIVIC CENTER	FS	FRENCH
8023	SA	WB	CIVIC CENTER	NS	MAIN
8024	SA	WB	CIVIC CENTER	OPP	BOYD
8025	SA	WB	CIVIC CENTER	FS	RAITT
8026	SA	WB	CIVIC CENTER	FS	ENGLISH
8027	SA	WB	CIVIC CENTER	NS	FAIRVIEW
8028	SA	WB	5TH	NS	SUSAN
8029	SA	WB	HAZARD	@	CADDY
8030	WEST	WB	HAZARD	NS	NEWLAND
8031	WEST	WB	HAZARD	OPP	JEFFERSON
8032	WEST	WB	HAZARD	FS	BEACH
8033	WEST	WB	HAZARD	FS	CEDARWOOD
8034	WEST	WB	HAZARD	NS	HOOVER
8035	WEST	WB	HAZARD	FS	CHESTNUT
8036	RSM	WB	SANTA MARGARITA	FS	PLANO TRABUCO
8037	IRV	WB	MICHELSON	FS	PRINCE
8038	IRV	EB	MICHELSON	OPP	PRINCE
8039	MV	NB	PALA	NS	MADERO
8040	YL	EB	BASTANCHURY	FS	ROSE
8041	YL	EB	BASTANCHURY	FS	PROSPECT
8042	YL	EB	BASTANCHURY	FS	VALLEY VIEW
8043	YL	WB	BASTANCHURY	FS	IMPERIAL
8044	YL	WB	BASTANCHURY	NS	PROSPECT
8045	YL	WB	BASTANCHURY	FS	ROSE
8046	SA	SB	MAIN	OPP	EDGEWOOD
8047	OC	NB	JEFFREY	FS	TRABUCO
8048	LF	SB	ALTON	FS	PORTOLA
8049	LF	EB	PORTOLA	FS	PALOMA
8050	OR	EB	CHAPMAN	OPP	CLIFFWAY
8051	TUST	SB	TUSTIN RANCH	FS	PIONEER
8052	TUST	EB	EDINGER	FS	TUSTIN RANCH
8053	TUST	EB	BRYAN	NS	JAMBOREE
8054	TUST	SB	JAMBOREE	FS	TUSTIN RANCH
8055	IRV	EB	PORTOLA	FS	JAMBOREE
8056	IRV	SB	JAMBOREE	@	PIONEER
8057	IRV	NB	JAMBOREE	FS	IRVINE
8058	IRV	NB	JAMBOREE	NS	ROBINSON
8059	IRV	NB	JAMBOREE	NS	TREVINO
8060	IRV	NB	JAMBOREE	NS	CHAMPION
8061	IRV	NB	JAMBOREE	FS	PORTOLA
8063	IRV	WB	UNIVERSITY	OPP	CALIFORNIA
8064	LOSAL	EB	KATELLA	FS	WALLINGSFORD
8065	AV	NB	ALISO VIEJO	FS	PACIFIC PARK
8066	AV	NB	ALISO VIEJO	FS	GRAND

Bus Stop Maintenance**All Stop Locations**

RFP 1-3408

Exhibit A

Attachment 2

OCTA_ID	CITY	DIR	STREET_OF_TRAVEL	LOC	CROSS_STREET
8067	AV	NB	ALISO VIEJO	FS	ENTERPRISE
8068	AV	WB	ALISO VIEJO	FS	COLUMBIA
8069	AV	SB	ALISO VIEJO	FS	ENTERPRISE
8070	AV	SB	ALISO VIEJO	FS	GRAND
8071	AV	NB	COLUMBIA	FS	ALISO VIEJO
8072	AV	NB	COLUMBIA	VNS	ALISO CREEK
8073	AV	SB	COLUMBIA	FS	ALISO CREEK
8074	AV	EB	ENTERPRISE	NS	NOVA
8075	AV	NB	GLENWOOD	FS	BROOKLINE
8076	AV	SB	GLENWOOD	OPP	BROOKLINE
8077	AV	NB	PACIFIC PARK	NS	ENTERPRISE
8078	AV	EB	PACIFIC PARK	FS	ALISO VIEJO
8079	AV	EB	PACIFIC PARK	FS	JOURNEY
8080	AV	WB	PACIFIC PARK	FS	CITY LIGHTS
8083	LN	WB	LNMS	@	DOCK 1
8084	FULL	SB	HARBOR	NS	ELM
8085	CERR	WB	183RD	FS	GRIDLEY
8086	FULL	SB	PLACENTIA	OPP	CROWTHER
8087	IRV	SB	WEST YALE LOOP	NS	ALTON
8089	CERR	NB	GRIDLEY	FS	187TH
8091	GG	EB	GARDEN GROVE	OPP	PALM
8093	FV	NB	EUCLID	FS	NEWHOPE
8094	FV	SB	NEWHOPE	FS	TALBERT
8095	IRV	WB	LAKE FOREST	FS	SCIENTIFIC
8096	LAGH	EB	LAKE FOREST	FS	SANTA VITTORIA
8098	IRV	NB	FAIRCHILD	FS	ENT 19701 FDA
8099	AV	SB	ALISO CREEK	FS	PARK PLAZA
8100	AV	EB	ENTERPRISE	NS	SUMMIT
8101	AV	WB	ENTERPRISE	FS	ALISO CREEK
8102	AV	WB	ENTERPRISE	FS	SUMMIT
8103	AV	WB	ENTERPRISE	NS	PACIFIC PARK
8104	HG	SB	BLOOMFIELD	VNS	CARSON
8106	IRV	SB	JEFFREY	FS	IRVINE
8108	OR	SB	BATAVIA	NS	STRUCK
8109	LAGH	SB	SANTA VITTORIA	NS	RIDGE ROUTE
8110	SC	NB	CAMINO DE ESTRELLA	OPP	CALLE HERMOSA
8111	SC	NB	CAMINO DE LOS MARES	FS	CALLE NUEVO
8112	SC	EB	CAMINO VERA CRUZ	FS	CAMINO DE LOS MARES
8113	SC	EB	CAMINO VERA CRUZ	OPP	SARMENTOSO
8114	SC	EB	CAMINO VERA CRUZ	FS	CALLE DE LOS ARBOLES
8115	SC	EB	CAMINO VERA CRUZ	FS	AVD VISTA HERMOSA
8116	SC	WB	AVD PICO	OPP	CALLE AMANECER
8117	SC	EB	AVD PICO	FS	CALLE AMANECER
8118	SC	WB	CAMINO VERA CRUZ	FS	AVD VISTA HERMOSA
8119	SC	WB	CAMINO VERA CRUZ	FS	CAMINO DE LA LADERA
8120	SC	WB	CAMINO VERA CRUZ	FS	SARMENTOSO

Bus Stop Maintenance

All Stop Locations

RFP 1-3408

Exhibit A

Attachment 2

OCTA_ID	CITY	DIR	STREET_OF_TRAVEL	LOC	CROSS_STREET
8121	SC	SB	CAMINO DE LOS MARES	OPP	CAMINO VERA CRUZ
8122	SC	SB	CAMINO DE LOS MARES	OPP	CALLE NUEVO
8123	SC	SB	WALMART	VNS	PLAZA PACIFICA
8124	BP	NB	STANTON	FS	ORANGETHORPE
8125	BP	NB	STANTON	OPP	11TH
8126	BP	SB	STANTON	FS	AUTO CENTER
8127	BP	SB	STANTON	NS	11TH
8128	ANA	EB	LINCOLN	NS	MONTEREY
8129	ANA	WB	LINCOLN	FS	MONTEREY
8130	CYP	SB	VALLEY VIEW	FS	PLAZA
8131	SA	EB	GARDEN GROVE	OPP	THE CITY
8132	SA	WB	MACARTHUR	FS	BEAR
8133	TUST	NB	TUSTIN RANCH	FS	BARANCA
8134	TUST	NB	TUSTIN RANCH	FS	SOUTH LOOP
8135	TUST	NB	TUSTIN RANCH	FS	WARNER
8136	TUST	SB	TUSTIN RANCH	OPP	WARNER
8137	TUST	SB	TUSTIN RANCH	OPP	SOUTH LOOP
8138	TUST	EB	WARNER	FS	TUSTIN RANCH
8139	TUST	EB	WARNER	FS	SOUTH LOOP
8140	TUST	WB	BARRANCA	OPP	MILLIKAN
8141	IRV	SB	ALTON	FS	IRVINE
8142	IRV	SB	YALE	FS	BRYAN
8143	HB	SB	BEACH	FS	PACIFIC VIEW
8144	SJC	SB	CAMINO CAPISTRANO	FS	JUNIPERO SERRA
8145	ANA	EB	BALL	OPP	GAYMONT
8146	ANA	WB	BALL	FS	GAYMONT
8147	SA	NB	SANTA ANA BASE INTERIOR	@	LAYOVER ZONE
8148	LA	SB	FLOWER	FS	PICO
8149	LA	SB	FLOWER	NS	VENICE
8150	LA	SB	FLOWER	FS	WASHINGTON
8151	LA	SB	FLOWER	FS	ADAMS
8152	IRV	EB	IRVINE	FS	GROVELAND
8153	IRV	SB	SAND CANYON	FS	PORTOLA
8154	IRV	NB	SAND CANYON	OPP	PA 9B
8155	LF	NB	EL TORO	FS	RAYMOND
8156	SA	NB	FLOWER	FS	SUNFLOWER
8158	ANA	WB	ORANGEWOOD	OPP	RAMPART
8159	ANA	WB	ORANGEWOOD	OPP	DUPONT
8160	ANA	WB	ORANGEWOOD	NS	STATE COLLEGE
8161	LH	EB	IMPERIAL	FS	BEACH
8162	LH	EB	IMPERIAL	FS	LA HABRA HEIGHTS
8163	LH	EB	IMPERIAL	FS	TOWN & COUNTRY
8164	LH	EB	IMPERIAL	OPP	WALNUT
8165	LH	WB	IMPERIAL	FS	BEACH
8166	FULL	EB	IMPERIAL	FS	BONITA
8167	FULL	WB	IMPERIAL	FS	BONITA

Bus Stop Maintenance
All Stop Locations

RFP 1-3408
Exhibit A
Attachment 2

OCTA_ID	CITY	DIR	STREET_OF_TRAVEL	LOC	CROSS_STREET
8168	BREA	WB	IMPERIAL	FS	STATE COLLEGE
8169	SA	NB	FIRST AMERICAN	VNS	COLUMBINE
8170	SA	SB	FIRST AMERICAN	VFS	COLUMBINE
8171	OR	NB	JAMBOREE	FS	HANDY CREEK
8172	OR	NB	JAMBOREE	FS	CANYON VIEW
8173	OR	SB	JAMBOREE	OPP	HANDY CREEK
8174	OR	NB	GLASELL	FS	QUINCY
8175	IRV	SB	HARVARD	FS	SWEET SHADE
8176	TUST	EB	WARNER	FS	JUNEBERRY
8177	TUST	WB	WARNER	FS	HARVARD
8178	FULL	EB	COMMONWEALTH	NS	EDWARD
8179	SA	NB	IMPERIAL PROMENADE	FS	FIRST AMERICAN
8180	SA	SB	IMPERIAL PROMENADE	FS	MACARTHUR PLACE
8181	LA	NB	HARBOR TRANSITWAY	@	ROSECRANS
8182	LA	NB	HARBOR TRANSITWAY	@	GLENN ANDERSON
8183	LA	NB	HARBOR TRANSITWAY	@	MANCHESTER
8184	LA	NB	HARBOR TRANSITWAY	@	SLAUSON
8185	LA	NB	HARBOR TRANSITWAY	@	37TH
8186	LA	SB	HARBOR TRANSITWAY	@	37TH
8187	LA	SB	HARBOR TRANSITWAY	@	SLAUSON
8188	LA	SB	HARBOR TRANSITWAY	@	MANCHESTER
8189	LA	SB	HARBOR TRANSITWAY	@	GLENN ANDERSON
8190	LA	SB	HARBOR TRANSITWAY	@	ROSECRANS
8191	LF	SB	EL TORO	FS	ORCHARDS
8192	POM	SB	GILLETTE	FS	ENT POMOMA FAIRPLEX PNR
8193	IRV	NB	PACIFICA	FS	ALTON
8194	IRV	EB	BARRANCA	FS	IRVINE CENTER
8195	IRV	WB	BARRANCA	FS	IRVINE CENTER
8196	CH	EB	GRAND	FS	CHINO HILLS
8197	CH	EB	GRAND	FS	PEYTON
8198	CH	WB	GRAND	FS	PEYTON
8199	CH	WB	GRAND	FS	CHINO HILLS
8200	CHNO	EB	CHINO PNR	@	BOARDING DOCK
8201	CHNO	SB	6TH	FS	D
8202	ANA	EB	VIA BURTON	FS	DALY
8203	POM	WB	I-10 FAIRPLEX OFF-RAMP	@	FAIRPLEX PNR
8204	ANA	SB	ANAHEIM BASE INTERIOR	@	LAYOVER ZONE
8205	IRV	NB	FORTUNE	NS	PACIFICA
8206	LA	WB	8TH	NS	SPRING
8207	LA	WB	8TH	NS	BROADWAY
8208	LA	WB	8TH	NS	HILL
8209	LA	WB	8TH	NS	OLIVE
8210	TUST	WB	SYCAMORE	FS	RED HILL
8211	TUST	WB	SYCAMORE	NS	CARFAX
8212	LF	EB	PORTOLA	FS	GLENN RANCH
8213	LF	SB	PORTOLA	FS	SADDLEBACK

Bus Stop Maintenance

RFP 1-3408

All Stop Locations

Exhibit A

Attachment 2

OCTA_ID	CITY	DIR	STREET_OF_TRAVEL	LOC	CROSS_STREET
8214	LF	SB	SANTA MARGARITA	VFS	EL TORO
8215	LF	NB	PORTOLA	FS	EL TORO
8216	LF	NB	PORTOLA	FS	SADDLEBACK
8217	LF	WB	PORTOLA	NS	GLENN RANCH
8218	LF	WB	PORTOLA	FS	LAKE FOREST
8219	OC	NB	ANTONIO	FS	CROWN VALLEY
8220	OC	NB	ANTONIO	OPP	BENJAMIN
8221	OC	SB	ANTONIO	FS	BENJAMIN
8222	OC	EB	CROWN VALLEY	FS	CECIL PASTURE
8223	OC	EB	CROWN VALLEY	FS	ONEILL
8224	OC	EB	CROWN VALLEY	FS	SIENNA
8225	OC	WB	CROWN VALLEY	VFS	ANTONIO
8226	OC	WB	CROWN VALLEY	NS	ONEILL
8227	OC	WB	CROWN VALLEY	FS	SPORTS PARK
8228	OC	NB	ANTONIO	FS	SWEETWATER
8229	OC	NB	ANTONIO	FS	OAKTREE
8230	OC	SB	ANTONIO	FS	MEANDERING TRAIL
8231	OC	SB	ANTONIO	FS	SEACOUNTRY
8232	OC	SB	ANTONIO	FS	SABLE
8233	OC	SB	ANTONIO	FS	OSO
8234	RS	SB	GALLERIA AT TYLER	@	BOARDING DOCK
8235	COR	SB	CANYON COMMUNITY CHURCH	@	BOARDING DOCK
8236	LF	NB	BAKE	OPP	RANCHO
8237	LF	SB	BAKE	FS	RANCHO
8238	SC	EB	AVD PICO	FS	AVD LA PATA
8239	SC	EB	AVD PICO	OPP	THE COURTYARDS
8240	SC	EB	AVD PICO	FS	AVD VISTA HERMOSA
8241	SC	EB	AVD PICO	FS	CALLE ALICANTE
8242	SC	EB	AVD PICO	FS	CAMINO CELOSIA
8243	SC	WB	AVD PICO	FS	AVD VISTA HERMOSA
8244	SC	WB	AVD PICO	FS	THE COURTYARDS
8245	SC	WB	AVD PICO	FS	AVD LA PATA
8246	SC	NB	CAMINO LA PEDRIZA	FS	CRISTIANITOS
8247	SC	NB	CAMINO LA PEDRIZA	FS	CORTE TIERRA BELLA
8248	SC	NB	CAMINO LA PEDRIZA	FS	CORTE MIRA VISTA
8249	SC	WB	CAMINO LA PEDRIZA	FS	VIA AMOR
8250	SC	WB	CAMINO LA PEDRIZA	FS	CALLE VISTA DEL SOL
8251	SC	SB	CAMINO LA PEDRIZA	FS	CALLE PACIFICA
8252	SC	SB	AVD VISTA HERMOSA	OPP	CAMINO LA PEDRIZA

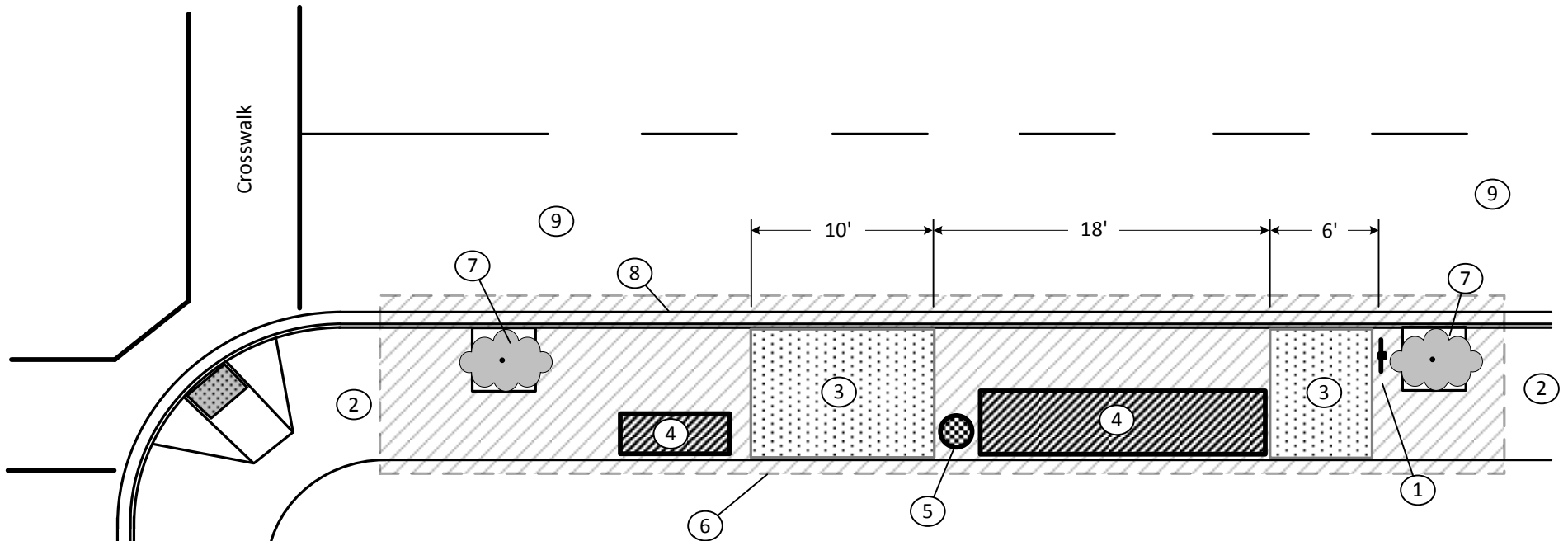

NOTES:

- ▨ Area to be inspected when performing Task I & Task II (actual size varies by location).
- ① Bus stop sign, post, & informational signage - inspect and repair as needed.
- ② Inspect condition of sidewalk.
- ③ Any obstacles within front and/or rear door boarding areas will be relocated or removed.
- ④ Inspect shelter(s) and/or bench(es) when servicing the stop.
- ⑤ Empty all trash receptacle(s).
- ⑥ Trash will also be picked up from behind the sidewalk/boarding area.
- ⑦ Trim tree(s) or other vegetation extending out over the sidewalk and/or into the roadway.
- ⑧ Inspect curb & gutter for damages and remove any trash or debris.
- ⑨ Inspect roadway for pot holes or other damages.

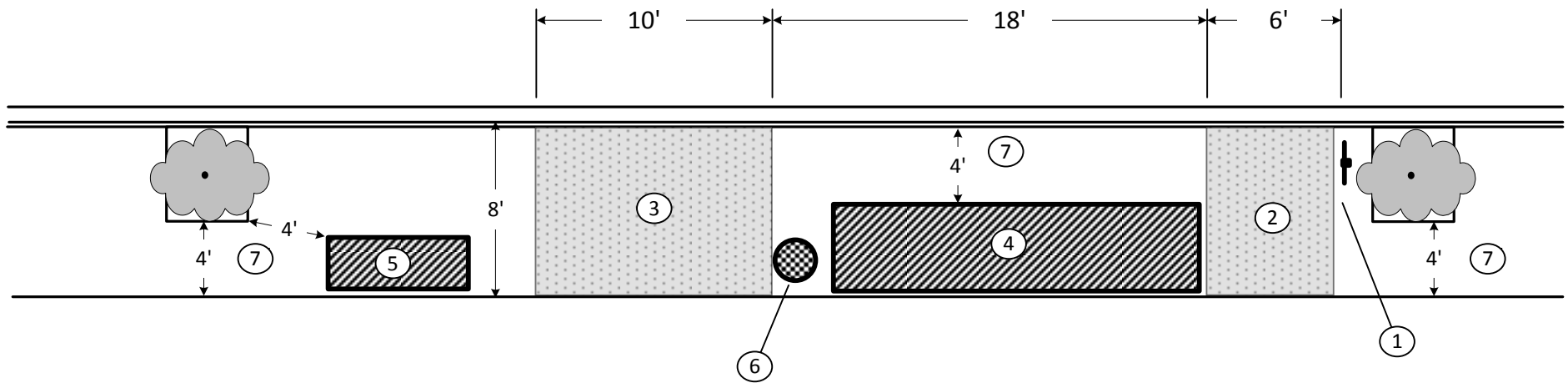

NOTES:

- ① Bus stop sign, post, & informational signage
- ② Front door wheelchair boarding area
- ③ Rear door wheelchair boarding area
- ④ Typical shelter location between boarding areas
- ⑤ Bench location when shelter is present
- ⑥ Trash receptacle placed 3' to 4' from bench or shelter
- ⑦ 4 ft. minimum clearance around all objects or obstacles.

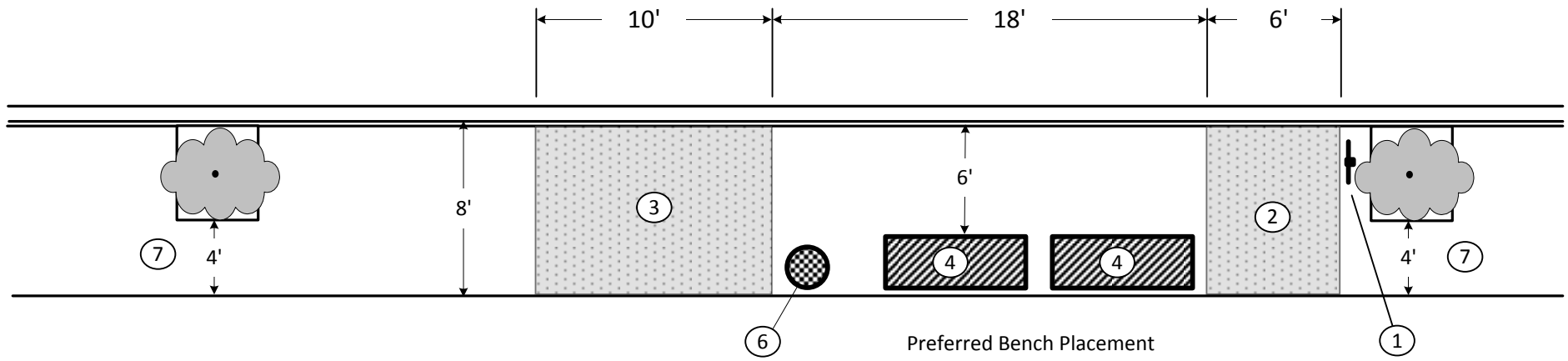

Preferred Bench Placement

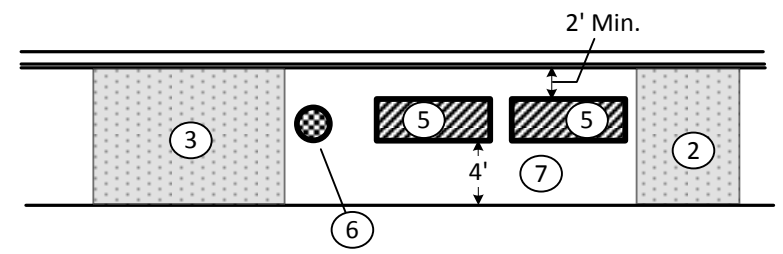

Alternate Bench Placement

NOTES:

- ① Bus stop sign, post, & informational signage
- ② Front door wheelchair boarding area
- ③ Rear door wheelchair boarding area
- ④ Preferred bench location (on back side of sidewalk)
- ⑤ Alternate bench location
- ⑥ Trash receptacle placed 3' to 4' from bench(es)
- ⑦ 4 ft. minimum clearance around all objects

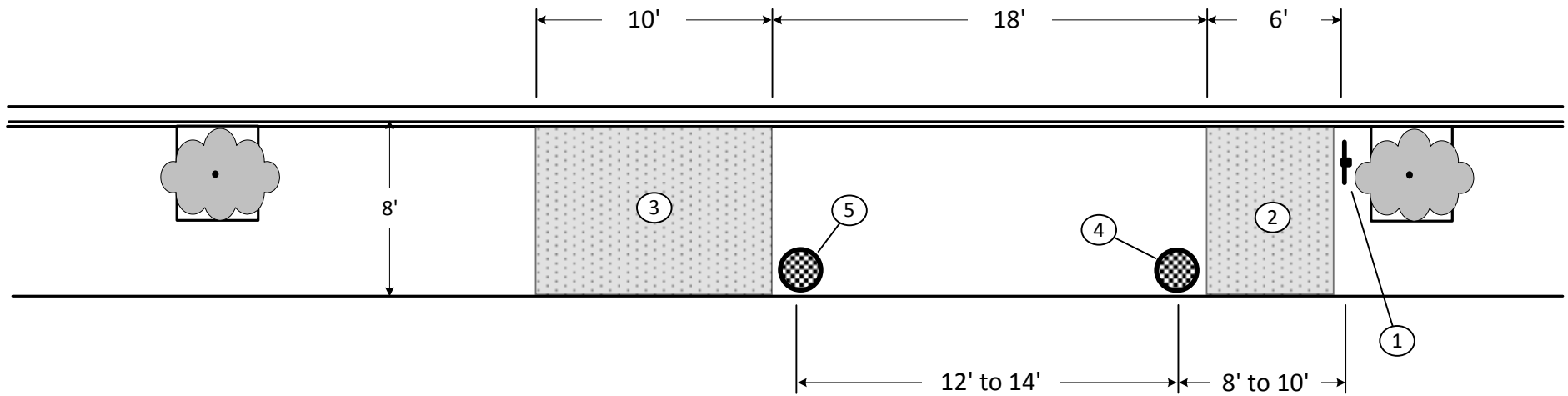

NOTES:

- ① Bus stop sign, post, & informational signage.
- ② Front door wheelchair boarding area.
- ③ Rear door wheelchair boarding area.
- ④ Trash receptacle placed on backside of sidewalk, 8' to 10' from sign post.
- ⑤ Location for additional trash receptacle (if needed).

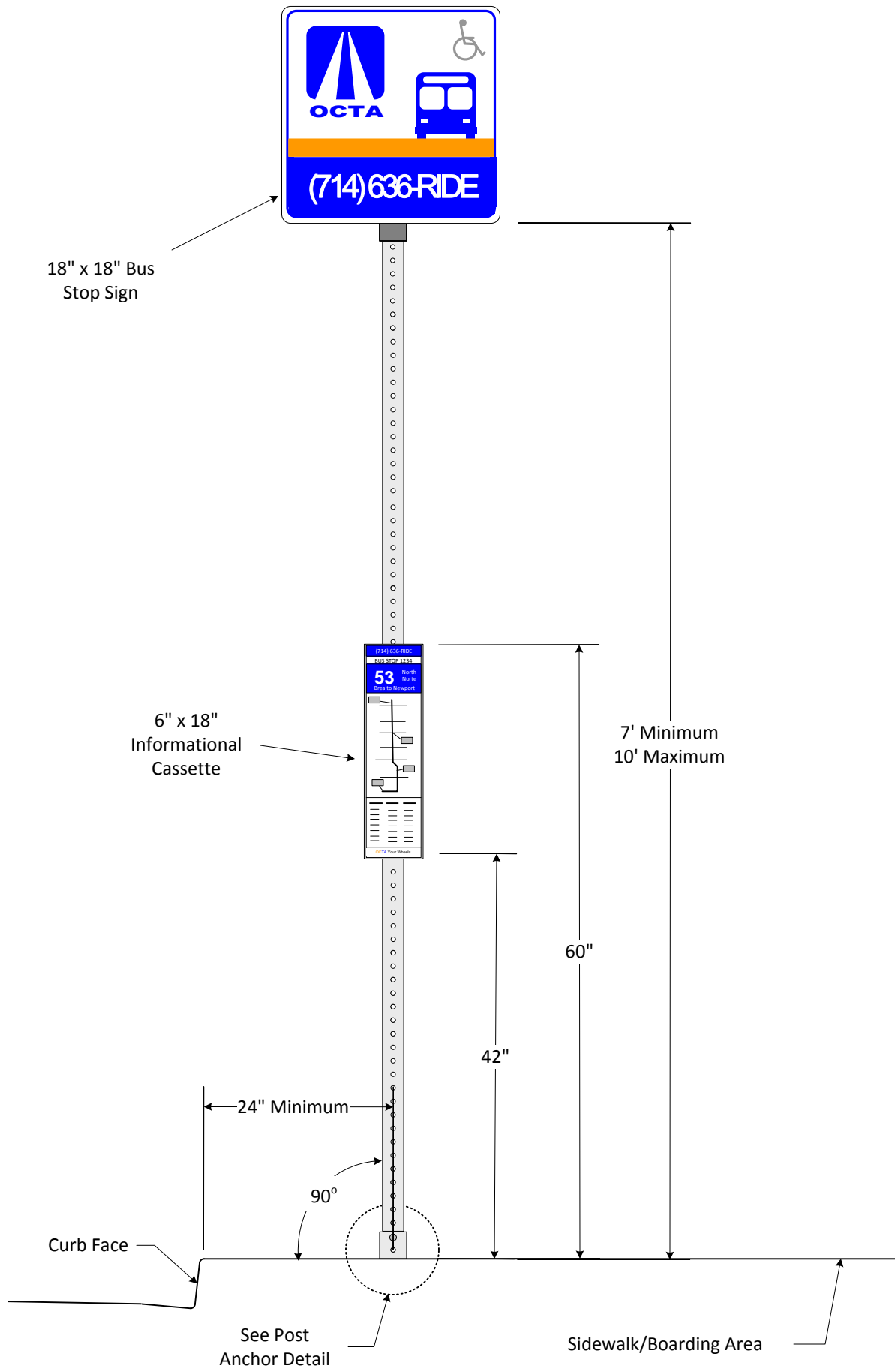

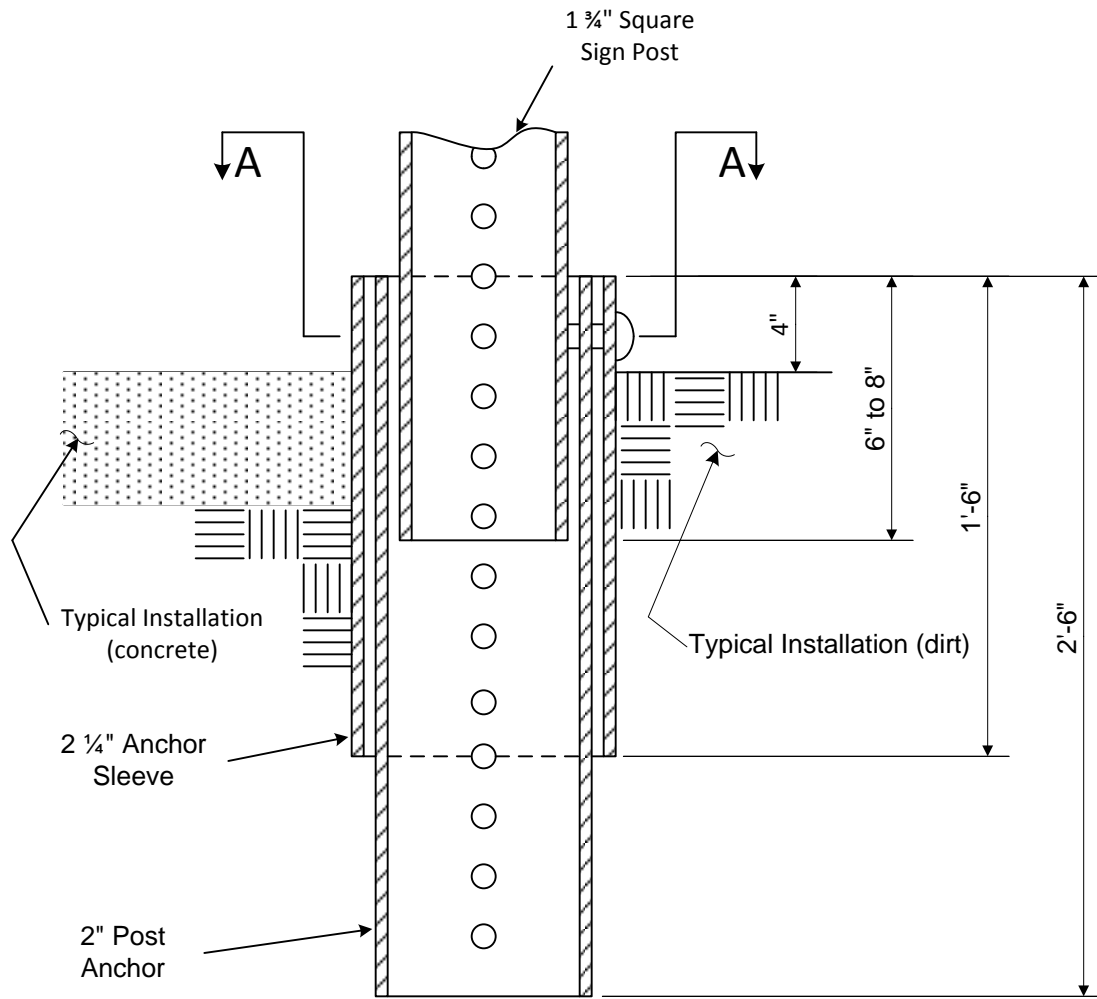

TYPICAL CROSS SECTION

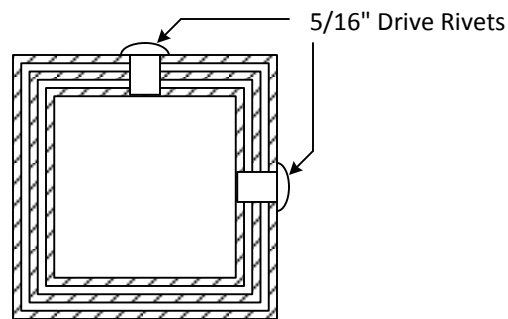

SECTION A-A

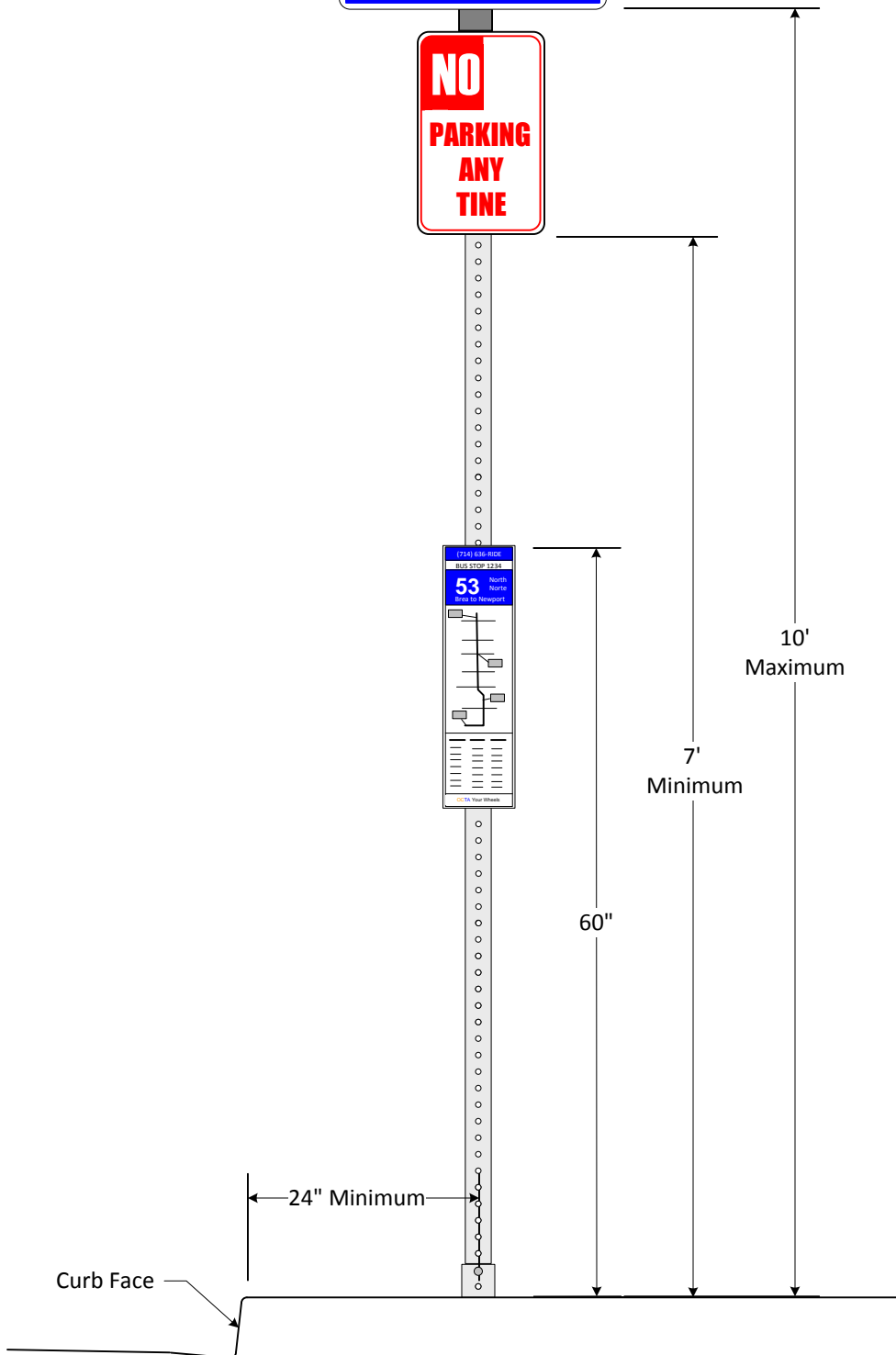
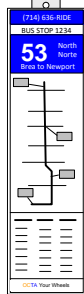

NOTE:

- 1) The OCTA bus stop sign should be top mounted above city sign(s) (unless directed otherwise).
- 2) If the bus stop sign is removed, all city signs will be raised to the top of the sign post.

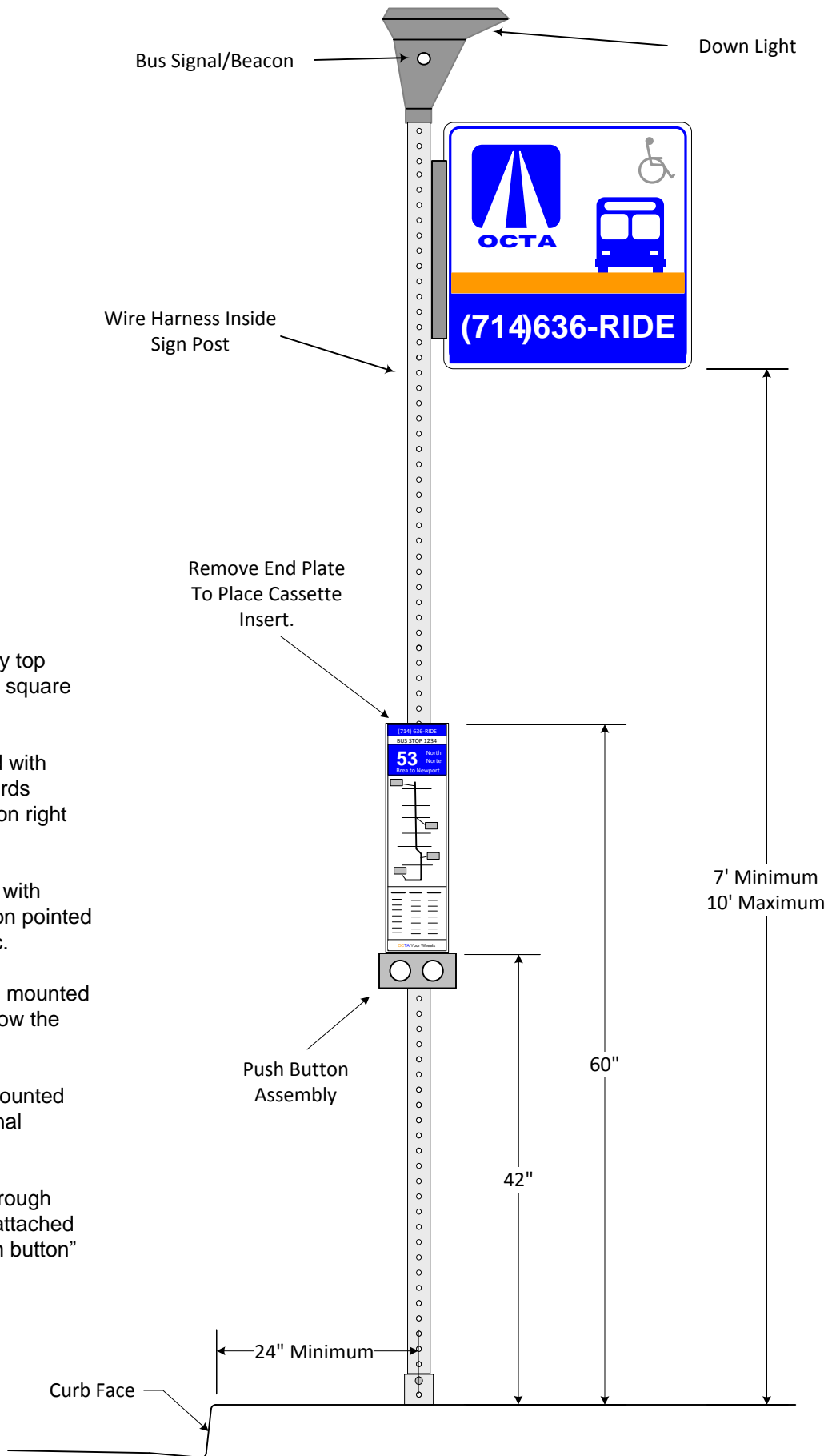

NOTE:

- 1) Solar light head assembly top mounted on standard 10' square sign post.
- 2) Head assembly installed with down light oriented towards sidewalk/boarding area on right side of sign post.
- 3) Head assembly installed with flashing bus signal/beacon pointed towards on-coming traffic.
- 4) The bus stop sign is side mounted on right side of post, below the solar light.
- 5) Push button assembly mounted directly below informational cassette.
- 6) Wire harness inserted through center of sign post and attached to both "head" and "push button" assemblies.

Down Light

Bus Signal/Beacon



Wire Harness Inside Sign Post

Remove End Plate To Place Cassette Insert.

NOTE:

- 1) Solar light head assembly top mounted on standard 10' square sign post.
- 2) The solar light placed on back side or behind sidewalk when existing width is less than six (6) feet.
- 3) Head assembly installed with down light facing towards street.
- 4) Head assembly installed with flashing bus signal/beacon pointed towards on-coming traffic.
- 5) The bus stop sign is side mounted on left side of post, below the solar light.
- 6) Push button assembly mounted directly below informational cassette.
- 7) Wire harness inserted through center of sign post and attached to both "head" and "push button" assemblies.

7' Minimum
10' Maximum

60"

42"

Push Button Assembly

Back Side of Sidewalk

Curb Face

< 6' (see note 2)

←
 Bus Stop Sign
 Facing
 Approaching
 Traffic

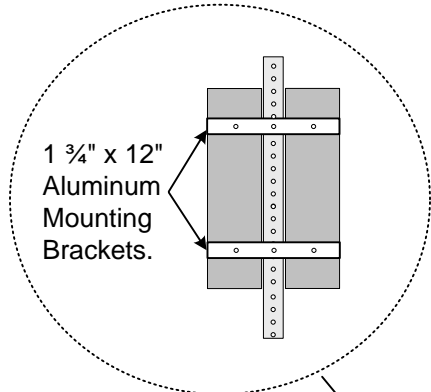

Rear View
 Mounting Detail

Remove End Plate
 To Place Cassette
 Insert.

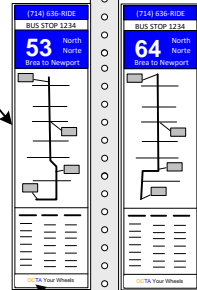

7' Minimum
 10' Maximum

60"

60"

42"

Note: Cassettes inserts
 are placed from left-to-
 right or front-to-back in
 numerical order based on
 route number.

24" Minimum

Curb Face

Side View
 Back-To-Back
 Configuration

Front View
 Side-By-Side
 Configuration

Sidewalk/
 Boarding Area

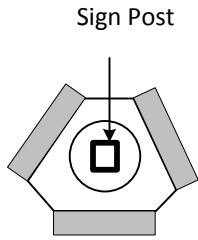

Top View
3 Sided Rotating
Cassette Bracket

18" high x 10" diameter

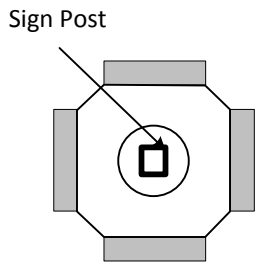

Top View
4 Sided Rotating
Cassette Bracket

18" high x 11" diameter

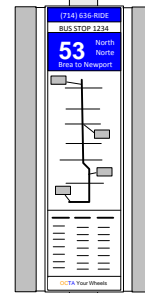

Remove End Plate
To Place Cassette
Insert.

7' Minimum
10' Maximum

42"

60"

NOTE:

Inserts at locations with multiple cassettes will be placed in a counter-clockwise position based on the numerical route number (lowest to highest).

Curb Face

24" Minimum

Sidewalk/
Boarding Area

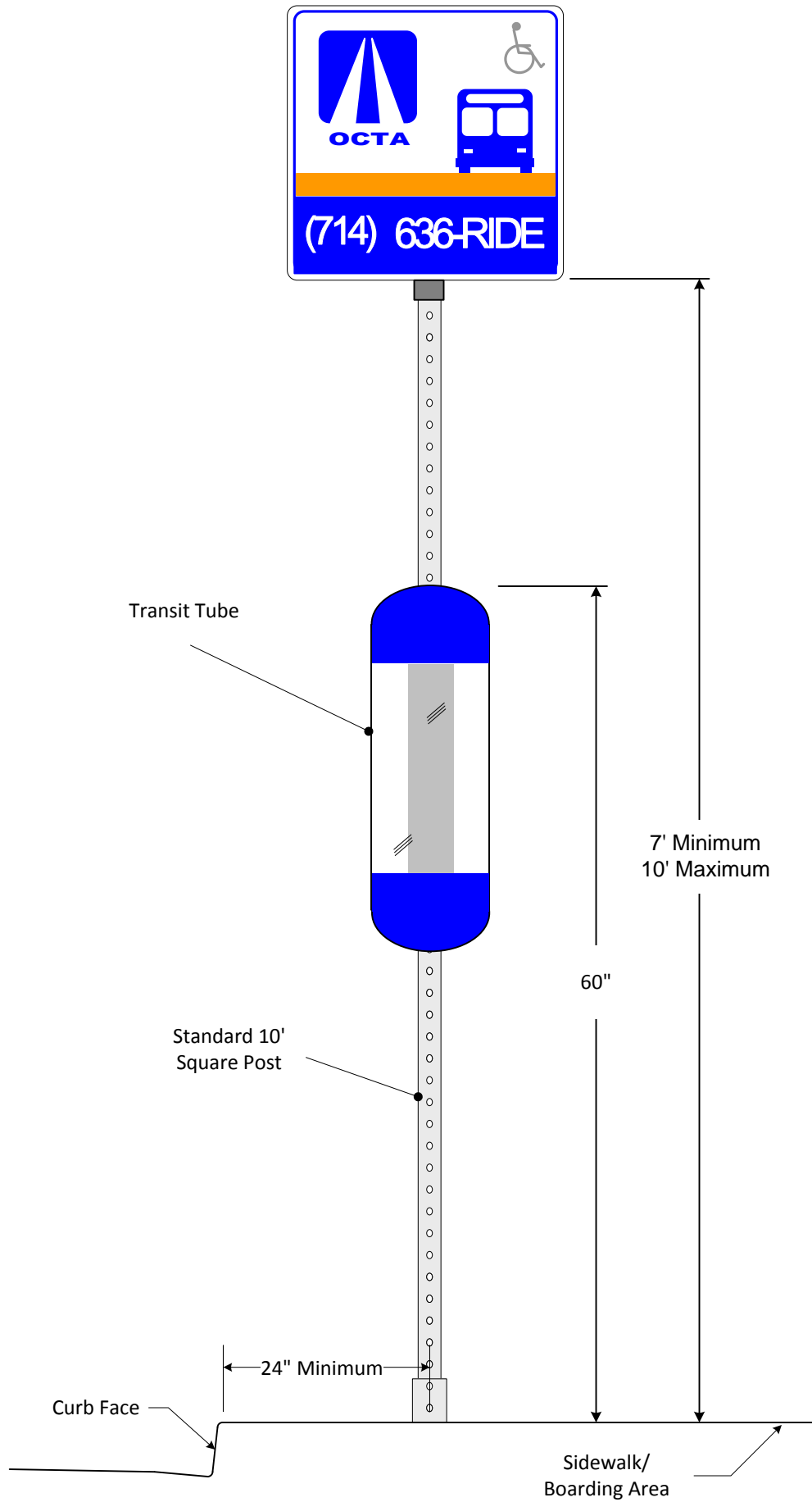

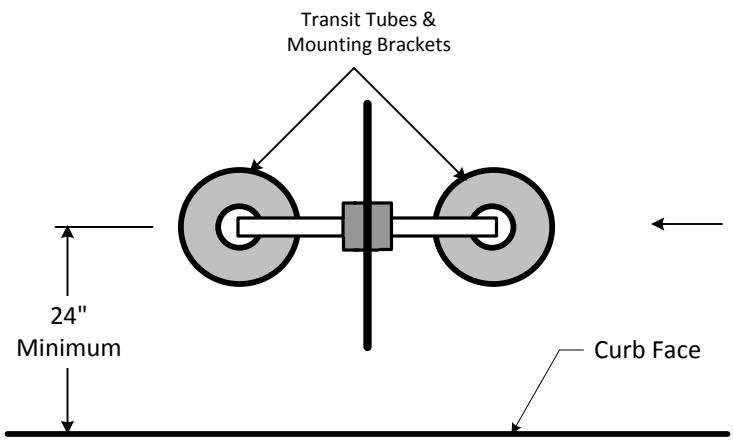

Dual transit tubes are mounted parallel to the adjacent curb/roadway.

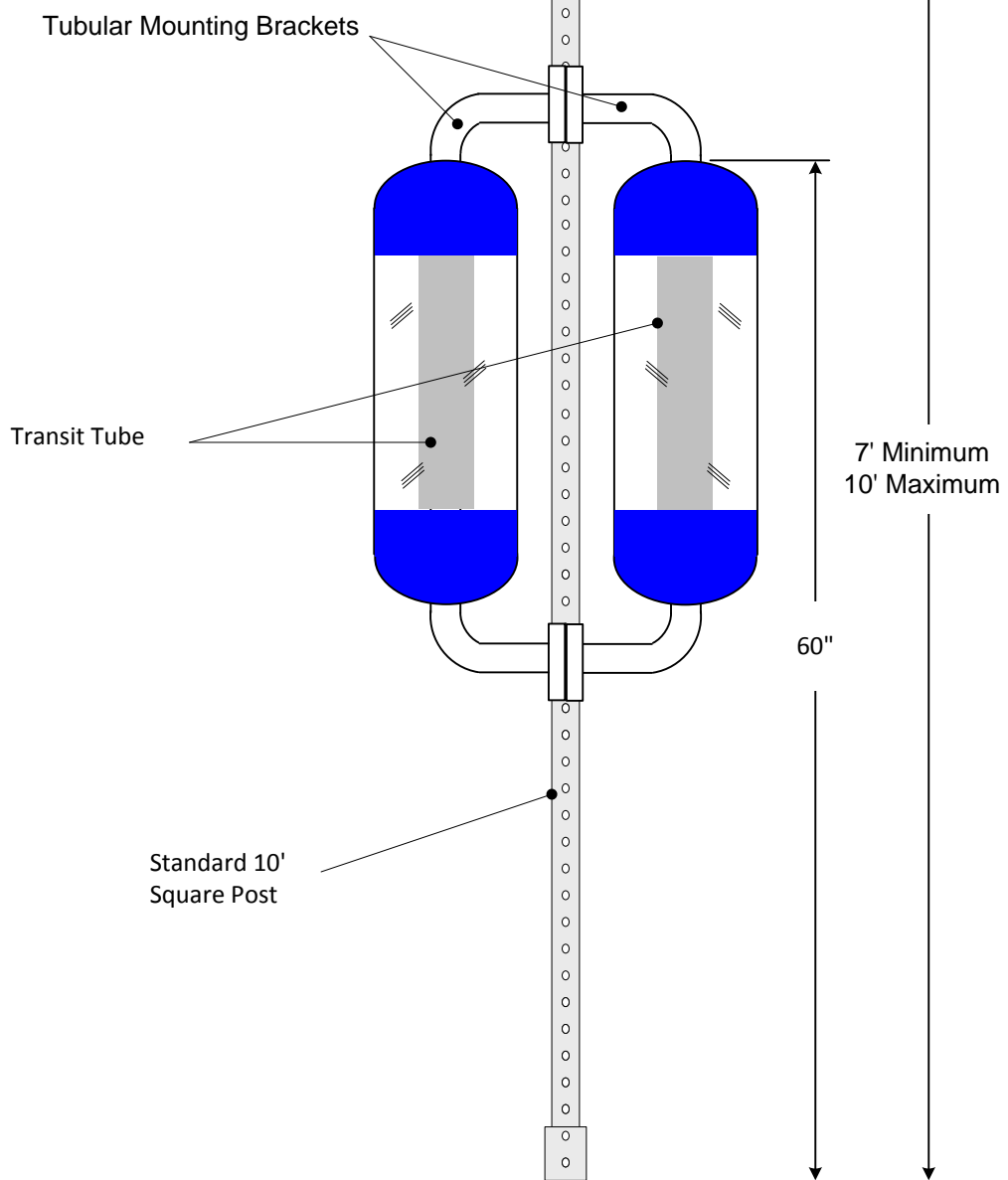

6" x 30" Type I Bus Exempt Sign

BUS EXEMPT

30" x 30" R18 Sign

RIGHT LANE

MUST

TURN RIGHT

7' Minimum

NOTE:

Type I "Bus Exempt" signs will be top mounted above each R18 sign. Typically R18 signs are located at the beginning of a right turn pocket and at the curb return.

Curb Face

30"-36" Min.

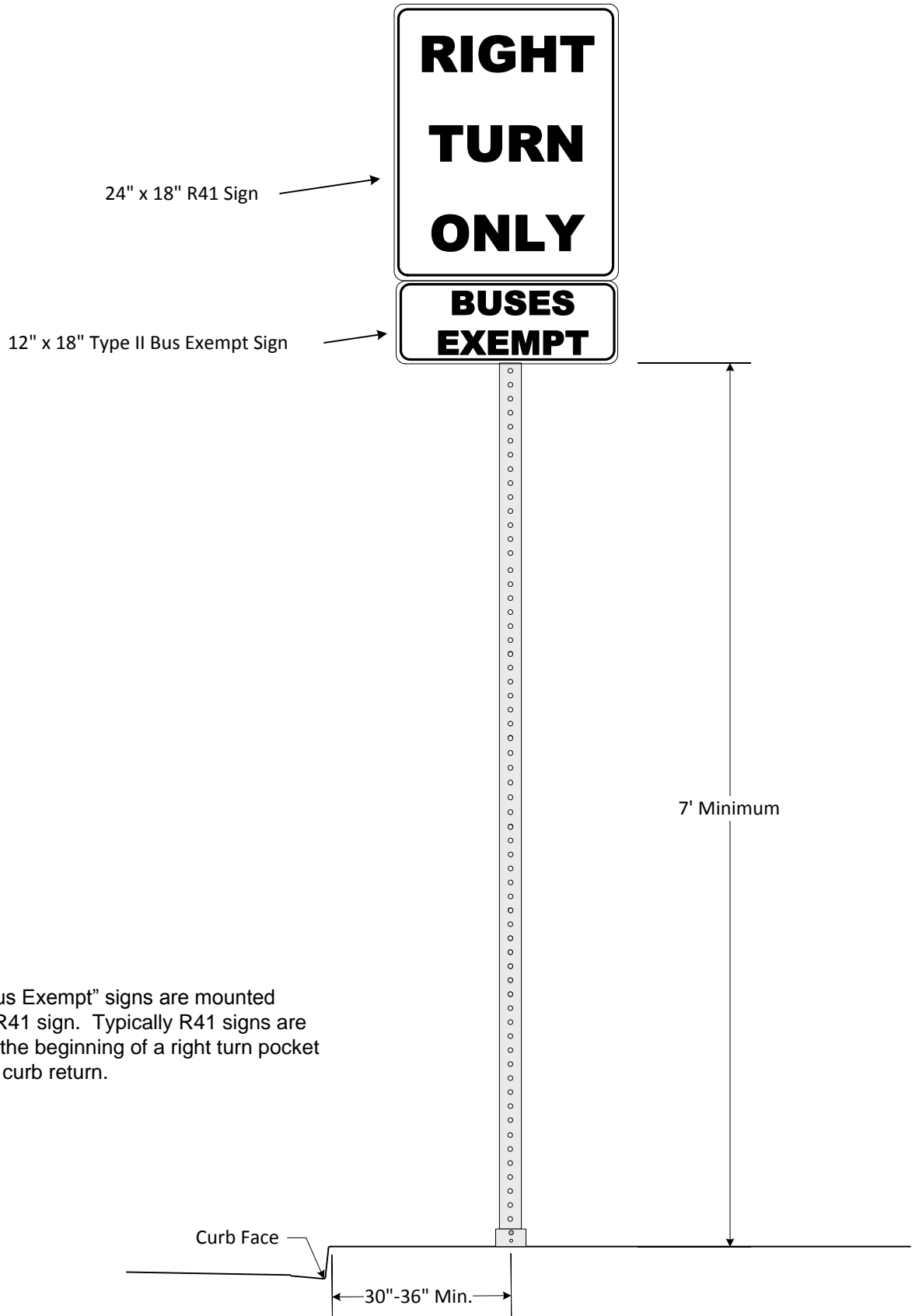

NOTE:

Type II "Bus Exempt" signs are mounted below an R41 sign. Typically R41 signs are located at the beginning of a right turn pocket and at the curb return.

Light Standard Mounting Configurations

Street Side

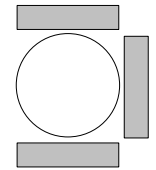

Three Cassettes (standard position)

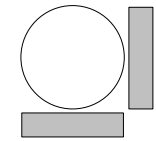

Dual Cassettes ("L" shape right)

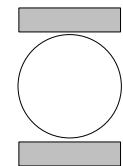

Dual Cassettes (back-to-back)

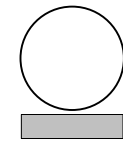

Single Cassette (standard)

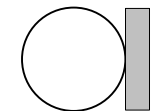

Single Cassette (standard right)

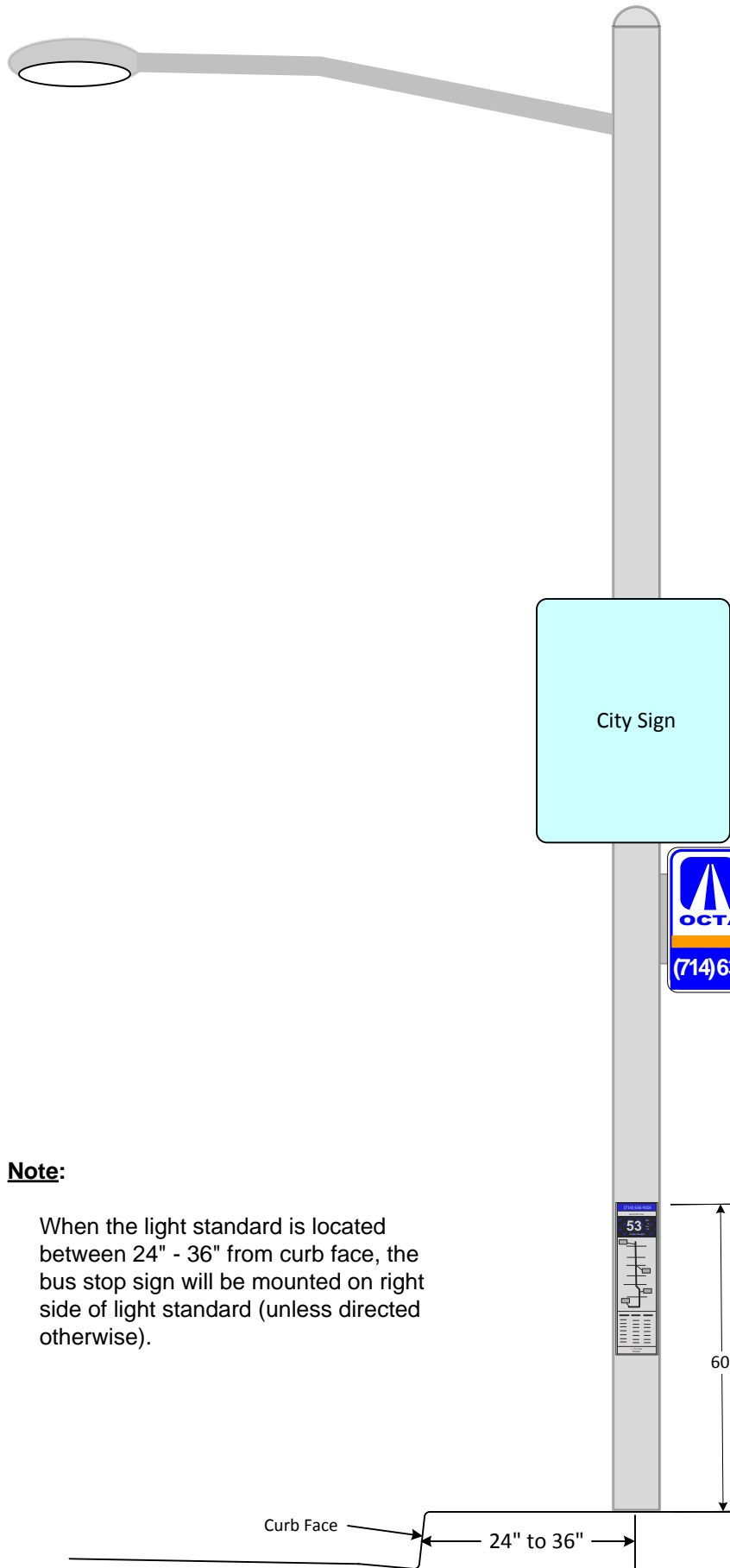

Note:

When the light standard is located between 24" - 36" from curb face, the bus stop sign will be mounted on right side of light standard (unless directed otherwise).

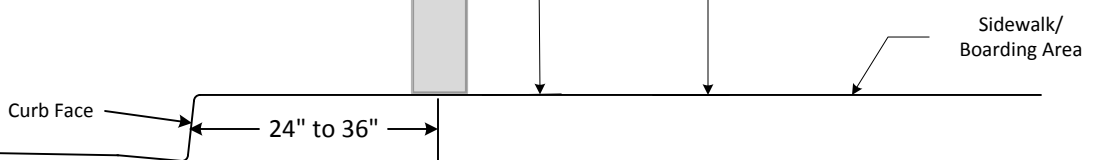

Light Standard Mounting Configurations

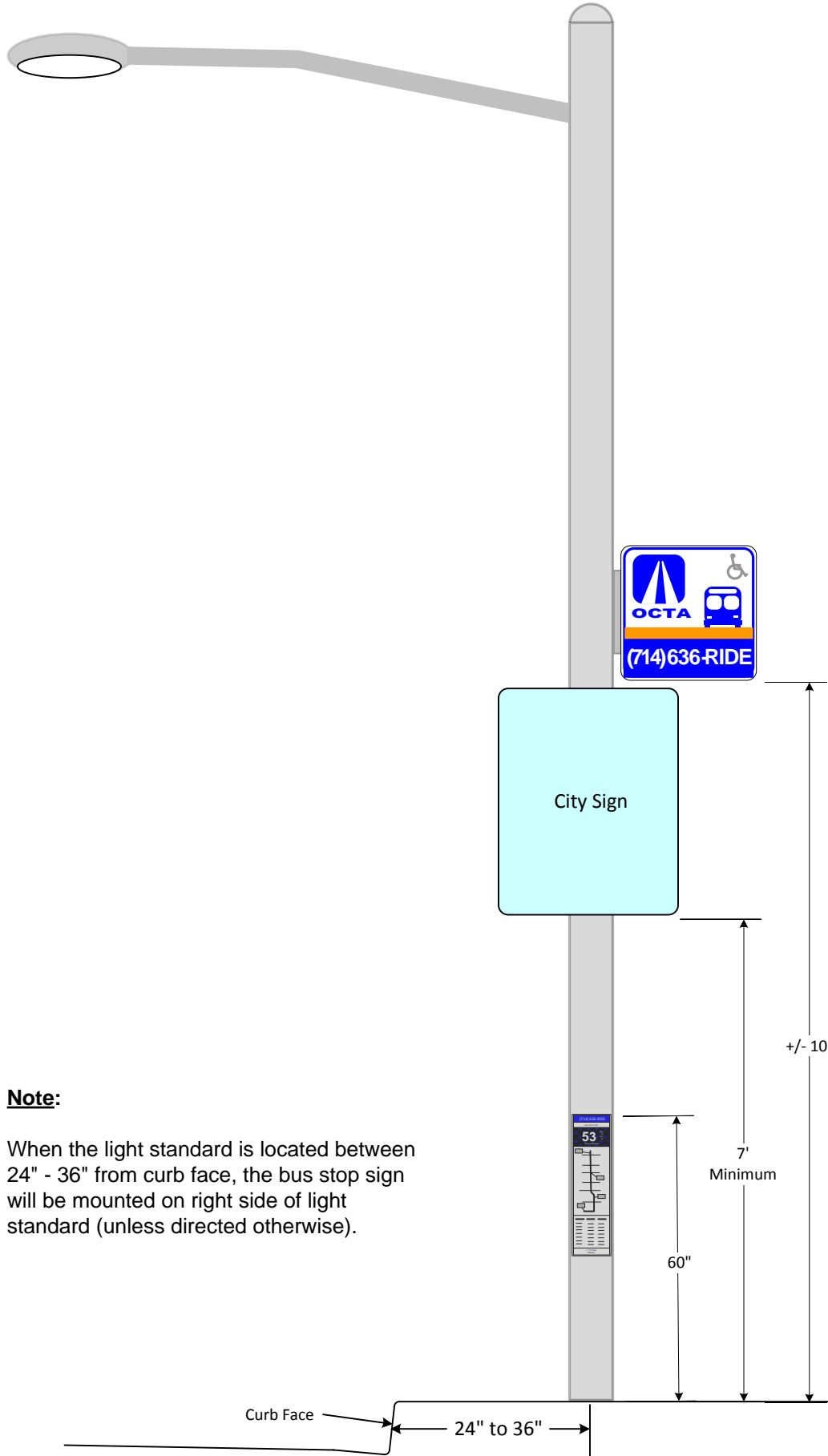
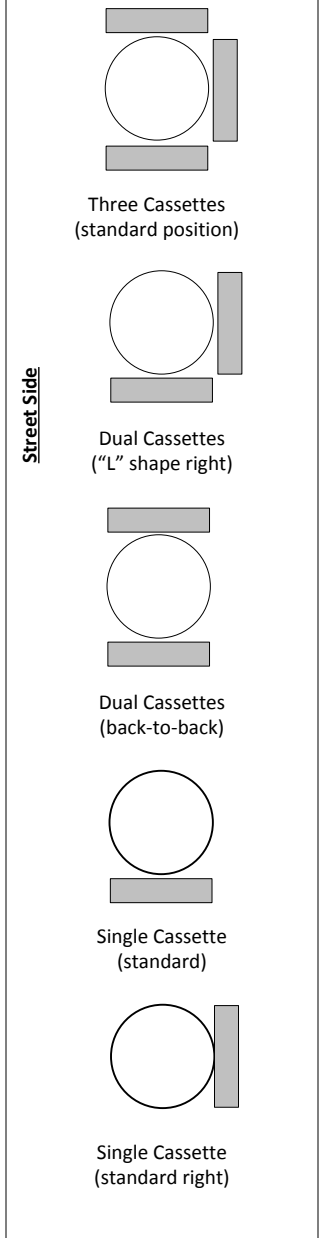

Note:

When the light standard is located between 24" - 36" from curb face, the bus stop sign will be mounted on right side of light standard (unless directed otherwise).

Light Standard Mounting Configurations

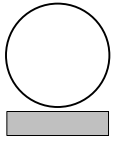

Single Cassette (standard)

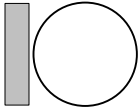

Single Cassette (standard left)

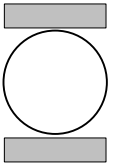

Dual Cassettes (back-to-back)

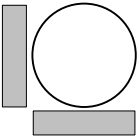

Dual Cassettes ("L" shape left)

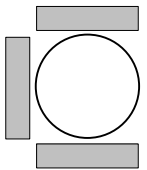

Three Cassettes (standard position)

Street Side

Note:

When light standard is located more than 36" from curb face, the bus stop sign will be mounted on left side (unless directed otherwise).

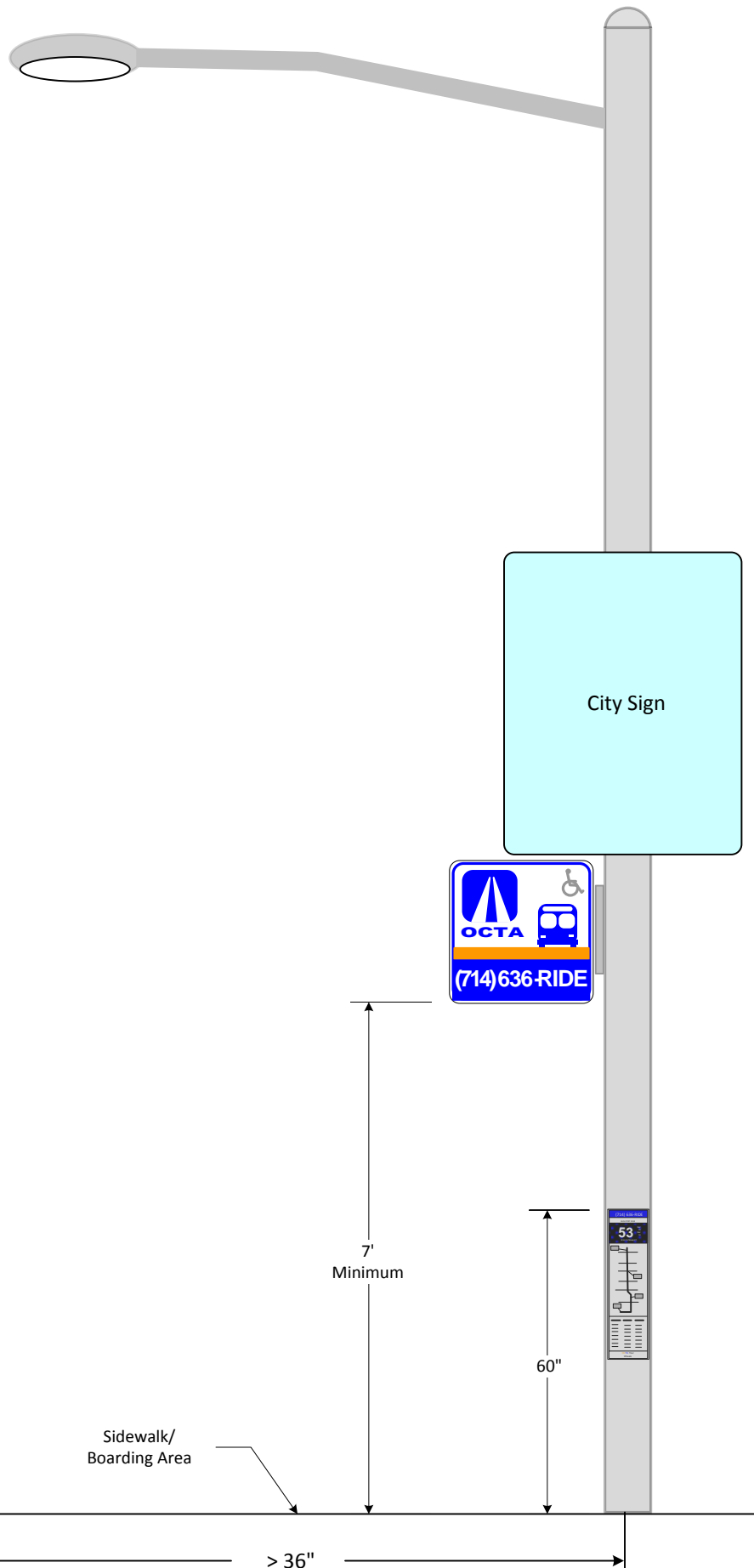

**Light Standard
Mounting Configurations**

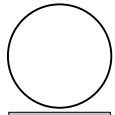

Single
Cassette
(standard)

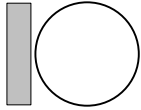

Single
Cassette
(standard
left)

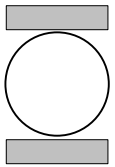

Dual Cassettes
(back-to-back)

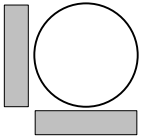

Dual Cassettes
("L" shape left)

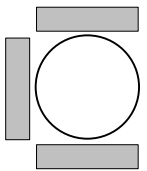

Three Cassettes
(standard position)

Street Side

Note:

When light standard is located more than 36" from curb face, the bus stop sign will be mounted on left side (unless directed otherwise).

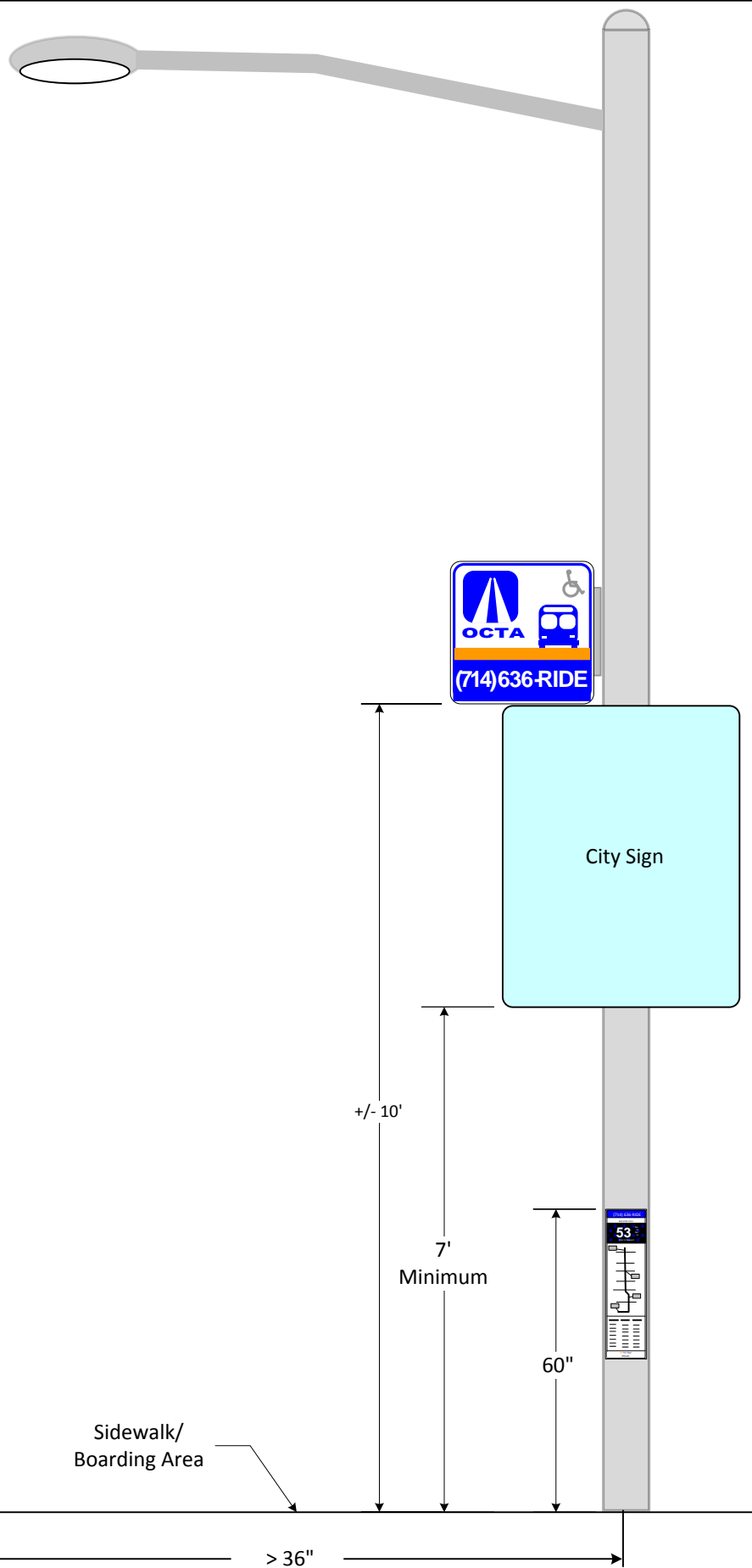

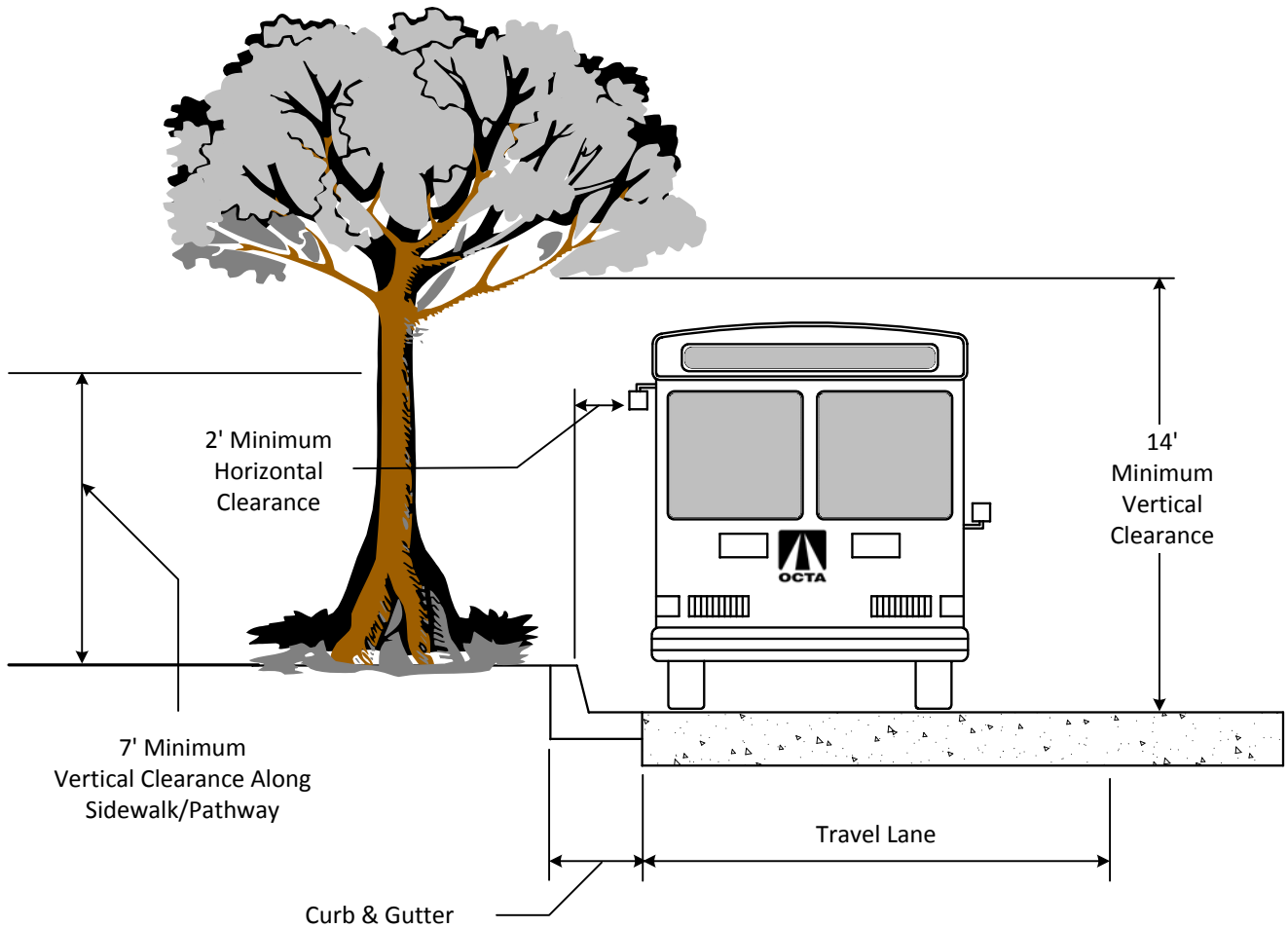

NOTE:

- 1) Tree branches or other vegetation hanging below 14' will be trimmed or removed.
- 2) Tree branches or other vegetation extending more than 2 feet beyond curb face will be trimmed or removed.
- 3) Tree branches or other vegetation extending out over the sidewalk or boarding area, below 7' will be trimmed or removed.

Additional Required Safe Work Practices

Abrasive Blasting

Abrasive blasting operations shall comply with SCAQMD Rule 1140, CCR Title 8, 5155, 5144, and 5149. Prior to abrasive blasting operations the Contractor shall provide a JSA to OCTA Project Manager a minimum of seven day prior to the scheduled activity.

All abrasive blasting shall be wet-blasting and vacuum method to minimize and manage dust plumbs. Contractor shall use a non-silica blast media to minimize public health concerns. Blasting containment methods are required where there is the potential of public exposure and/or property damage.

Sand Reservoir and Hose Assembly

- Barricade the activity area using type 2 barricades and caution tape for protection of workers and the public.
- Review Safe Operating Procedures for applicable equipment and perform pre-operational checks.
- Check all fittings for leaks and alignments.
- Muffler should be attached to compressor to reduce blowback noise.
- Check position of all valves before activating blaster. Nozzle should have a "Dead Man" shutoff valve.
- Drain water from the separator.
- Stand clear and do not face sand reservoir after filling. Be careful not to overfill.
- Keep unauthorized personnel out of immediate sandblast area.
- Check blasting hoses for rips, tears and soft spots. Do not use defective hoses.
- Check nozzle shutoff mechanism prior to use and check nozzle for wear.
- Do not allow vehicles to run over hoses. Avoid kinks and sharp turns in hoses.
- Avoid dragging hoses over concrete or any surface that could induce wear.

Sandblasting Hood

- Adjust helmet headband and chin strap to proper size. Clean and disinfect hood before use.
- Make sure hood-skirting is fitted down over shoulder and snaps are fastened.
- The waist belt for the air hose should be worn outside of skirting to allow easy adjustment.
- Check the air supply system.
- Long sleeve shirts, safety glasses, safety shoes and hearing protection are required.
- A positive pressure air hood is required. The supplied air must be at least Grade D breathable air.

Grade D air has the following characteristics:

- Oxygen content from 19.5 to 23.5 percent
- Condensed oil at 5 mg/m³
- Carbon monoxide (CO) not to exceed 10 parts per million (ppm)
- Carbon dioxide (CO₂) not to exceed 1,000 (ppm)
- No odor

High Pressure Water Cleaning

High Pressure Water Cleaning scope activity shall comply with 29 CFR 1926.21, 1926.59, 1926.62, and CCR Title 8, Standards.

Introduction and Definition of Pressure Washing:

High pressure water washing (or cleaning, jetting) is defined as the use of high pressure water, with or without the addition of other liquids or solid particles, to remove unwanted matter from various surfaces, where the pressure of the liquid jet exceeds 1,000 PSIG at the orifice (or nozzle). The lower limit of 1,000 PSIG does not mean that pressures below 1,000 PSIG cannot cause injury or require any less attention to the principal of these recommended practices. Adequate precautions, similar to those of these recommended practices, are required at all pressures.

This standard operating procedure provides only minimum general requirements. The equipment manufacturer's manual should be read and followed.

Pressure Washing Equipment Requirements:

Automatic Pressure Relief: The system shall be equipped with an automatic pressure relief device on the discharge side of the pump, adjusted so that the manufacturer's maximum allowable system pressure is not exceeded.

Pressure Gauge: The system shall be equipped with a gauge to indicate the pressure being developed.

Personal Protection Equipment:

Each operator shall wear, as a minimum, the following personnel protection equipment. Additional equipment may be necessary if chemical or other hazards are present.

- Whole Body: Liquid chemical resistant suits
- Head: Hard hat
- Eyes and Face: Face shield and safety glasses
- Foot: Waterproof steel toe/steel shank boots
- Hearing: Ear plugs or ear muffs

Operator Training:

Only trained (experienced) personnel shall operate high pressure washing equipment, and supervise the training of new operators.

Operational Rules:

- Barricade the activity area using type 2 barricades and caution tape for protection of workers and the public.
- Never operate the equipment above the manufacturer's rated pressure maximum.
- Increase pressure slowly until required working pressure is reached.
- Always rope off the area to be cleaned.
- Never point the nozzle at a person. Remember that a water jet can puncture splash suits and other personal protective clothing.

Concrete, Masonry, and Coring Activities

Concrete and masonry scope activity shall comply with 29 CFR 1926.700, and CCR Title 8 Standards.

The management of concrete and coring work hazards may include the following.

- Barricade the activity area using type 2 barricades and caution tape for protection of workers and the public.
- Concrete cutting/coring operations shall require adequate hearing protection.
- Personnel exposed to any concrete dust shall be protected from breathing dust by engineering controls and/or respiratory protection.
- Contractor shall ensure dust control measures are implemented to minimize airborne dust, control motorized equipment to prevent traffic hazards, ensure the visibility of ground personnel by equipment operators.
- The safety of workers placing concrete, enforce proper PPE for workers exposed to dermal or respiratory concrete cement hazards, eliminate potential impalement hazards, require safe work practices for cutting and forming channels, and inspect work areas daily for housekeeping of materials, tools, and equipment.
- Reinforcing steel bar placed vertically or horizontally shall be protected from posing an impalement hazard.

- Planning of dust creating tasks shall include control measures for potential exposure of the public or workers to concrete dust tasks or operations that dust could migrate to workers in the immediate area or down-wind breathing areas.
- No dry cutting of concrete or block unless airborne dust can be prevented, no sweeping, air-blowing of concrete dust, or mixing dry cement without proper respiratory protection and dust control measures.

Traffic Control Safeguards

Contractor shall be in compliance with the Manual on Uniform Traffic Control Devices (MUTCD), approved Traffic Control Plans (TCP's), the WATCH Manual, CCR Title 8 Standards and similar traffic and employee protective requirements shall be in compliance for traffic related activities.

Signs, signals and barricades shall be visible at all times where a hazard exists.

All streets, roads, highways, and other public thoroughfares which are closed to traffic shall be protected by effective barricades on which shall be placed acceptable and highly visible warning signs. Barricades must be located at the nearest intersecting public highway or street on each side of the blocked section.

All barricades and obstructions shall be illuminated by means of warning lights from sunset to sunrise. Materials stored upon or alongside public streets and highways shall be so placed, and the work at all times shall be so conducted, as to cause the minimum obstruction and inconvenience to the traveling public.

Barricades, signs, lights and other protective devices shall be installed and maintained in conformity with applicable statutory requirements and, where within railroad and highway right-of-way, as required by jurisdiction.

When any work is performed at night or where daylight is shut off or obscured, contractor shall, at its expense, provide artificial light sufficient to permit work to be carried on efficiently, satisfactorily and safely, and to permit thorough inspection. During such time periods the access to the place of work shall also be clearly illuminated. All wiring for electric light and power shall be installed and maintained in a professional manner, securely fastened in place at all points, and shall be kept as far as possible from telephone wires, signal wires, and wires used for firing blasts.

Signs, signals and barricades shall be removed when the hazard no longer exists.

Contractor employees working in an area of potential traffic hazards shall wear (class 2 or 3) reflective type vests and clothing.

EXHIBIT B: COST AND PRICE FORMS

PRICE SUMMARY SHEET

RFP 1-3408
EXHIBIT B

The firm-fixed unit prices below are for performing the maintenance services as described in Exhibit A, Scope of Work. Each unit price includes all direct costs, indirect costs, and profit.

	INITIAL THREE-YEAR TERM			1st OPTION TERM		2nd OPTION TERM	
	YEAR 1	YEAR 2	YEAR 3	YEAR 1	YEAR 2	YEAR 1	YEAR 2
	12-01-21 to 11-30-22	12-01-22 to 11-30-23	12-01-23 to 11-30-24	12-01-24 to 11-30-25	12-01-25 to 11-30-26	12-01-26 to 11-30-27	12-01-27 to 11-30-28
TASK 1 - PREVENTATIVE MAINTENANCE 5480 bus stop locations inspected and serviced once every 4 weeks or 13 times per year	\$ _____ per stop/ per visit	\$ _____ per stop/ per visit	\$ _____ per stop/ per visit	\$ _____ per stop/ per visit	\$ _____ per stop/ per visit	\$ _____ per stop/ per visit	\$ _____ per stop/ per visit
TASK 2 - CITY ASSISTANCE PROGRAM	\$ _____ per stop/ per visit	\$ _____ per stop/ per visit	\$ _____ per stop/ per visit	\$ _____ per stop/ per visit	\$ _____ per stop/ per visit	\$ _____ per stop/ per visit	\$ _____ per stop/ per visit
TASK 3 - MAINTENACE WORK ORDERS	Per Task Price	Per Task Price	Per Task Price	Per Task Price	Per Task Price	Per Task Price	Per Task Price
3.10 Install New Bus Stop Signs	\$ _____	\$ _____	\$ _____	\$ _____	\$ _____	\$ _____	\$ _____
3.11 Remove Bus Stop Signs	\$ _____	\$ _____	\$ _____	\$ _____	\$ _____	\$ _____	\$ _____
3.12 Relocate Bus Stop Signs (Existing Bus Zone)	\$ _____	\$ _____	\$ _____	\$ _____	\$ _____	\$ _____	\$ _____
3.13 Relocate Bus Stop Signs (New Location)	\$ _____	\$ _____	\$ _____	\$ _____	\$ _____	\$ _____	\$ _____
3.14 Replace Damage or Missing Bus Stop Signs	\$ _____	\$ _____	\$ _____	\$ _____	\$ _____	\$ _____	\$ _____
3.15 Place "No Parking" (R26) Signs	\$ _____	\$ _____	\$ _____	\$ _____	\$ _____	\$ _____	\$ _____
3.16 Place Type I "Bus Exempt" Signs	\$ _____	\$ _____	\$ _____	\$ _____	\$ _____	\$ _____	\$ _____
3.17 Place Type II "Bus Exempt" Signs	\$ _____	\$ _____	\$ _____	\$ _____	\$ _____	\$ _____	\$ _____
3.18 Place or Remove Miscellaneous Informational/ Directional Signs	\$ _____	\$ _____	\$ _____	\$ _____	\$ _____	\$ _____	\$ _____
3.19 Install New Bus Stop Sign and Post (Soft Surface)	\$ _____	\$ _____	\$ _____	\$ _____	\$ _____	\$ _____	\$ _____
3.20 Install New Bus Stop Sign and Post (Firm Surface)	\$ _____	\$ _____	\$ _____	\$ _____	\$ _____	\$ _____	\$ _____
3.21 Remove Bus Stop Sign and Post (Soft/Firm Surface)	\$ _____	\$ _____	\$ _____	\$ _____	\$ _____	\$ _____	\$ _____
3.22 Relocate Bus Stop Sign and Square Post (Existing Bus Zone)	\$ _____	\$ _____	\$ _____	\$ _____	\$ _____	\$ _____	\$ _____

PRICE SUMMARY SHEET

RFP 1-3408
EXHIBIT B

	INITIAL THREE-YEAR TERM			1st OPTION TERM		2nd OPTION TERM	
	YEAR 1	YEAR 2	YEAR 3	YEAR 1	YEAR 2	YEAR 1	YEAR 2
	12-01-21 to 11-30-22	12-01-22 to 11-30-23	12-01-23 to 11-30-24	12-01-24 to 11-30-25	12-01-25 to 11-30-26	12-01-26 to 11-30-27	12-01-27 to 11-30-28
	Per Task Price	Per Task Price	Per Task Price	Per Task Price	Per Task Price	Per Task Price	Per Task Price
3.23 Relocate Bus Stop Sign to Square Post (Existing Bus Zone)	\$	\$	\$	\$	\$	\$	\$
3.24 Relocate Bus Stop Sign and Post (New Location)	\$	\$	\$	\$	\$	\$	\$
3.25 Replace Damaged Sign Post	\$	\$	\$	\$	\$	\$	\$
3.26 Place Permanent or Temporary Cassette Insert	\$	\$	\$	\$	\$	\$	\$
3.27 Replace Damaged Cassette Lexan Shield	\$	\$	\$	\$	\$	\$	\$
3.28 Place or Replace Single Informational Cassette	\$	\$	\$	\$	\$	\$	\$
3.29 Place or Remove Dual Informational Cassettes	\$	\$	\$	\$	\$	\$	\$
3.30 Place or Remove Three or Four Sided Rotating Cassette Brackets	\$	\$	\$	\$	\$	\$	\$
3.31 Place or Remove Single Transit Tube	\$	\$	\$	\$	\$	\$	\$
3.32 Place or Remove Dual Transit Tubes	\$	\$	\$	\$	\$	\$	\$
3.33 Place Solar Lighting Unit (Standard Down Light Position)	\$	\$	\$	\$	\$	\$	\$
3.34 Place Solar Lighting Unit (Modified Down Light Position)	\$	\$	\$	\$	\$	\$	\$
3.35 Remove Solar Lighting Unit	\$	\$	\$	\$	\$	\$	\$
3.36 Relocate Solar Lighting Unit	\$	\$	\$	\$	\$	\$	\$
3.37 Replace Solar Light Head Assembly	\$	\$	\$	\$	\$	\$	\$
3.37a Replace Solar Light Battery	\$	\$	\$	\$	\$	\$	\$
3.38 Repair or Replace Solar Light Push Button Assembly	\$	\$	\$	\$	\$	\$	\$
3.39 Replace Solar Light Wire Harness	\$	\$	\$	\$	\$	\$	\$
3.40 Relocate Metal or Rod Iron Trash Receptable (Existing Bus Zone)	\$	\$	\$	\$	\$	\$	\$
3.41 Relocate Metal or Rod Iron Trash Receptable (New Bus Zone)	\$	\$	\$	\$	\$	\$	\$
3.42 Relocate Concrete Trash Receptacle(s)	\$	\$	\$	\$	\$	\$	\$
3.43 Relocate Metal or Rod Iron Bench(es) (Existing Bus Zone)	\$	\$	\$	\$	\$	\$	\$
3.44 Relocate Metal or Rod Iron Bench(es) (New Bus Zone)	\$	\$	\$	\$	\$	\$	\$

PRICE SUMMARY SHEET

RFP 1-3408
EXHIBIT B

	INITIAL THREE-YEAR TERM			1st OPTION TERM		2nd OPTION TERM	
	YEAR 1	YEAR 2	YEAR 3	YEAR 1	YEAR 2	YEAR 1	YEAR 2
	12-01-21 to 11-30-22	12-01-22 to 11-30-23	12-01-23 to 11-30-24	12-01-24 to 11-30-25	12-01-25 to 11-30-26	12-01-26 to 11-30-27	12-01-27 to 11-30-28
	Per Task Price	Per Task Price	Per Task Price	Per Task Price	Per Task Price	Per Task Price	Per Task Price
3.45 Relocate City Concrete Bench(es) (Existing Bus Stop)	\$	\$	\$	\$	\$	\$	\$
3.46 Remove Graffiti	\$	\$	\$	\$	\$	\$	\$
3.47 Empty Trash Receptacle(s)	\$	\$	\$	\$	\$	\$	\$
3.48 Trim Tree(s) and Bushes	\$	\$	\$	\$	\$	\$	\$
3.49 Remove Weeds	\$	\$	\$	\$	\$	\$	\$
3.50 General Bus Stop Maintenance	\$	\$	\$	\$	\$	\$	\$
3.51 Steam Clean Passenger Boarding Area	\$	\$	\$	\$	\$	\$	\$
3.52 Place Red Curb	\$	\$	\$	\$	\$	\$	\$
3.53 Remove Red Curb (Gray Out)	\$	\$	\$	\$	\$	\$	\$
3.54 Remove Red Curb (Sand-Blasting)	\$	\$	\$	\$	\$	\$	\$
3.55 Field Check Miscellaneous Bus Stop Locations	\$	\$	\$	\$	\$	\$	\$
3.56 Miscellaneous Work Orders	\$	\$	\$	\$	\$	\$	\$
3.57 Emergency Work Orders	\$	\$	\$	\$	\$	\$	\$

1. I acknowledge receipt of **RFP 1-3408** and Addenda No.(s)____.
2. This offer shall remain firm for _____ days from the date of proposal.
(Minimum of 120)

COMPANY NAME _____

ADDRESS _____

TELEPHONE _____

FACSIMILE # _____

EMAIL ADDRESS _____

SIGNATURE OF PERSON
AUTHORIZED TO BIND OFFEROR _____

NAME AND TITLE OF PERSON
AUTHORIZED TO BIND OFFEROR _____

DATE SIGNED _____

EXHIBIT C: PROPOSED AGREEMENT

PROPOSED AGREEMENT NO. C-1-3408

BETWEEN

ORANGE COUNTY TRANSPORTATION AUTHORITY

AND

THIS AGREEMENT is effective this 1st day of December, 2021 ("Effective Date"), by and between the Orange County Transportation Authority, 550 South Main Street, P.O. Box 14184, Orange, California 92863-1584, a public corporation of the State of California (hereinafter referred to as "AUTHORITY"), and , , , (hereinafter referred to as "CONTRACTOR").

WITNESSETH:

WHEREAS, AUTHORITY requires assistance from CONTRACTOR to provide bus stop maintenance services; and

WHEREAS, said work cannot be performed by the regular employees of AUTHORITY; and

WHEREAS, CONTRACTOR has represented that it has the requisite personnel and experience, and is capable of performing such services; and

WHEREAS, CONTRACTOR wishes to perform these services;

NOW, THEREFORE, it is mutually understood and agreed by AUTHORITY and CONTRACTOR as follows:

ARTICLE 1. COMPLETE AGREEMENT

A. This Agreement, including all exhibits and documents incorporated herein and made applicable by reference, constitutes the complete and exclusive statement of the terms and conditions of this Agreement between AUTHORITY and CONTRACTOR and it supersedes all prior representations, understandings and communications. The invalidity in whole or in part of any term or condition of this Agreement shall not affect the validity of other terms or conditions.

B. AUTHORITY's failure to insist in any one or more instances upon CONTRACTOR's performance of any terms or conditions of this Agreement shall not be construed as a waiver or

EXHIBIT C

1 relinquishment of AUTHORITY's right to such performance or to future performance of such terms or
2 conditions and CONTRACTOR's obligation in respect thereto shall continue in full force and effect.
3 Changes to any portion of this Agreement shall not be binding upon AUTHORITY except when
4 specifically confirmed in writing by an authorized representative of AUTHORITY by way of a written
5 amendment to this Agreement and issued in accordance with the provisions of this Agreement.

6 **ARTICLE 2. AUTHORITY DESIGNEE**

7 The Chief Executive Officer of AUTHORITY, or designee, shall have the authority to act for and
8 exercise any of the rights of AUTHORITY as set forth in this Agreement.

9 **ARTICLE 3. SCOPE OF WORK**

10 A. CONTRACTOR shall perform the work necessary to complete in a manner satisfactory to
11 AUTHORITY the services set forth in Exhibit A, entitled "Scope of Work," attached to and, by this
12 reference, incorporated in and made a part of this Agreement. All services shall be provided at the times
13 and places designated by AUTHORITY.

14 B. CONTRACTOR shall provide the personnel listed below to perform the above-specified
15 services, which persons are hereby designated as key personnel under this Agreement.

16 **Names**

Functions

17
18
19
20
21 C. No person named in paragraph B of this Article, or his/her successor approved by
22 AUTHORITY, shall be removed or replaced by CONTRACTOR, nor shall his/her agreed-upon function
23 or level of commitment hereunder be changed, without the prior written consent of AUTHORITY. Should
24 the services of any key person become no longer available to CONTRACTOR, the resume and
25 qualifications of the proposed replacement shall be submitted to AUTHORITY for approval as soon as
26 possible, but in no event later than seven (7) calendar days prior to the departure of the incumbent key

1 person, unless CONTRACTOR is not provided with such notice by the departing employee. AUTHORITY
2 shall respond to CONTRACTOR within seven (7) calendar days following receipt of these qualifications
3 concerning acceptance of the candidate for replacement.

4 **ARTICLE 4. TERM OF AGREEMENT**

5 A. This Agreement shall commence on December 1, 2021 and shall continue in full force and
6 effect through November 30, 2024, unless earlier terminated or extended as provided in this
7 Agreement.

8 B. AUTHORITY, at its sole discretion may elect to extend the term of this Agreement up to an
9 additional twenty-four (24) months, commencing December 1, 2024 and continuing through November
10 30, 2026 ("First Option Term"), and thereupon require CONTRACTOR to continue to provide services,
11 and otherwise perform, in accordance with Exhibit A, entitled "Scope of Work," at the rates set forth in
12 Article 5, "Payment."

13 C. AUTHORITY, at its sole discretion may elect to extend the term of this Agreement up to an
14 additional twenty-four (24) months, commencing December 1, 2026 and continuing through November
15 30, 2028 ("Second Option Term"), and thereupon require CONTRACTOR to continue to provide
16 services, and otherwise perform, in accordance with Exhibit A, entitled "Scope of Work," at the rates
17 set forth in Article 5, "Payment."

18 D. AUTHORITY's election to extend this Agreement beyond the Initial Term shall not diminish
19 its rights to terminate the Agreement for AUTHORITY's convenience or CONTRACTOR's default as
20 provided elsewhere in this Agreement. The "maximum term" of this Agreement shall be
21 the period extending from December 1, 2021 through November 30, 2028, which period encompasses
22 the Initial Term, First and Second Option Terms.

23 **ARTICLE 5. PAYMENT**

24 A. For CONTRACTOR's full and complete performance of its obligations under this Agreement
25 and subject to the maximum cumulative payment obligation provisions set forth in Article 6, AUTHORITY
26 shall pay CONTRACTOR on a time and expense-price basis in accordance with the following provisions.

EXHIBIT C

1 B. For the work satisfactorily performed by CONTRACTOR's personnel under this Agreement,
2 AUTHORITY shall pay CONTRACTOR at the price specified in Exhibit B, entitled "Price Summary
3 Sheet", attached to, and by this reference, incorporated in and made a part of this Agreement. These
4 prices shall remain fixed for the term of this Agreement and are acknowledged to include
5 CONTRACTOR's direct costs, indirect costs, taxes and profit. The schedule shall not include any
6 CONTRACTOR's expenses not approved by AUTHORITY, including, but not limited to reimbursement
7 for local meals.

8 C. CONTRACTOR shall invoice AUTHORITY on a monthly basis for payments corresponding
9 to the work actually completed by CONTRACTOR. Percentage of work completed shall be documented
10 in a monthly progress report prepared by CONTRACTOR, which shall accompany each invoice submitted
11 by CONTRACTOR. CONTRACTOR shall also furnish such other information as may be requested by
12 AUTHORITY to substantiate the validity of an invoice. At its sole discretion, AUTHORITY may decline to
13 make full payment for any work until such time as CONTRACTOR has documented to AUTHORITY's
14 satisfaction, that CONTRACTOR has fully completed all work required. AUTHORITY's payment in full
15 for any task completed shall constitute AUTHORITY's final acceptance of CONTRACTOR's work under
16 such task.

17 D. Invoices shall be submitted by CONTRACTOR on a monthly basis and shall be submitted in
18 duplicate to AUTHORITY's Accounts Payable office. CONTRACTOR may also submit invoices
19 electronically to AUTHORITY's Accounts Payable Department at vendorinvoices@octa.net. Each invoice
20 shall be accompanied by the monthly progress report specified in paragraph C of this Article.
21 AUTHORITY shall remit payment within thirty (30) calendar days of the receipt and approval of each
22 invoice. Each invoice shall include the following information:

- 23 1. Agreement No. C-1-3408;
- 24 2. Specify the work for which payment is being requested;
- 25 3. The time period covered by the invoice;
- 26 4. Total monthly invoice (including project-to-date cumulative invoice amount);

5. Monthly Progress Report;

6. Certification signed by the CONTRACTOR or his/her designated alternate that a)

The invoice is a true, complete and correct statement of reimbursable costs and progress; b) The backup information included with the invoice is true, complete and correct in all material respects; c) All payments due and owing to subcontractors and suppliers have been made; d) Timely payments will be made to subcontractors and suppliers from the proceeds of the payments covered by the certification and; e) The invoice does not include any amount which CONTRACTOR intends to withhold or retain from a subcontractor or supplier unless so identified on the invoice.

E. Any other information as agreed or requested by AUTHORITY to substantiate the validity of an invoice.

ARTICLE 6. MAXIMUM OBLIGATION

Notwithstanding any provisions of this Agreement to the contrary, AUTHORITY and CONTRACTOR mutually agree that AUTHORITY's maximum cumulative payment obligation (including obligation for CONTRACTOR's profit) shall be _____ Dollars (\$.00) which shall include all amounts payable to CONTRACTOR for its subcontracts, leases, materials and costs arising from, or due to termination of, this Agreement.

ARTICLE 7. NOTICES

All notices hereunder and communications regarding the interpretation of the terms of this Agreement, or changes thereto, shall be effected by delivery of said notices in person or by depositing said notices in the U.S. mail, registered or certified mail, returned receipt requested, postage prepaid and addressed as follows:

To CONTRACTOR:

To AUTHORITY:

Orange County Transportation Authority

550 South Main Street

P.O. Box 14184

Orange, CA 92863-1584

1 ATTENTION:

ATTENTION: Sue Ding

2 Sr. Contract Administrator

3 (714) 560 - 5631

4 sding@octa.net

5 **ARTICLE 8. INDEPENDENT CONTRACTOR**

6 A. CONTRACTOR's relationship to AUTHORITY in the performance of this Agreement is that of
7 an independent contractor. CONTRACTOR's personnel performing services under this Agreement shall
8 at all times be under CONTRACTOR's exclusive direction and control and shall be employees of
9 CONTRACTOR and not employees of AUTHORITY. CONTRACTOR shall pay all wages, salaries and
10 other amounts due its employees in connection with this Agreement and shall be responsible for all
11 reports and obligations respecting them, such as social security, income tax withholding, unemployment
12 compensation, workers' compensation and similar matters.

13 B. Should CONTRACTOR's personnel or a state or federal agency allege claims against
14 AUTHORITY involving the status of AUTHORITY as employer, joint or otherwise, of said personnel, or
15 allegations involving any other independent contractor misclassification issues, CONTRACTOR shall
16 defend and indemnify AUTHORITY in relation to any allegations made.

17 **ARTICLE 9. INSURANCE**

18 A. CONTRACTOR shall procure and maintain insurance coverage during the entire term of this
19 Agreement. Coverage shall be full coverage and not subject to self-insurance
20 provisions. CONTRACTOR shall provide the following insurance coverage:

21 1. Commercial General Liability, to include Products/Completed Operations,
22 Independent Contractors', Contractual Liability, and Personal Injury Liability, and Property Damage with
23 a minimum limit of \$1,000,000.00 per occurrence and \$2,000,000.00 general aggregate;

24 2. Automobile Liability Insurance to include owned, hired and non-owned autos with
25 a combined single limit of \$1,000,000.00 each accident;

EXHIBIT C

1 3. Workers' Compensation with limits as required by the State of California including
2 a waiver of subrogation in favor of AUTHORITY, its officers, directors, employees or agents;

3 4. Employers' Liability with minimum limits of \$1,000,000.00;

4 5. Professional Liability with minimum limits of \$1,000,000.00 per claim; and

5 6. Pollution Liability with minimum limits of \$1,000,000.00.

6 B. Proof of such coverage, in the form of a certificate of insurance, with the AUTHORITY, its
7 officers, directors, employees and agents, designated as additional insureds as required by contract. In
8 addition, provide an insurance policy blanket additional insured endorsement. Both documents must be
9 received by AUTHORITY prior to commencement of any work. Proof of insurance coverage must be
10 received by AUTHORITY within ten (10) calendar days from the effective date of this Agreement. Such
11 insurance shall be primary and non-contributive to any insurance or self-insurance maintained by the
12 AUTHORITY. Furthermore, AUTHORITY reserves the right to request certified copies of all related
13 insurance policies.

14 C. CONTRACTOR shall include on the face of the certificate of insurance the Agreement
15 Number C-1-3408; and, the Contract Administrator's Name, Sue Ding.

16 D. CONTRACTOR shall also include in each subcontract the stipulation that subcontractors
17 shall maintain insurance coverage in the amounts required from CONTRACTOR as provided in this
18 Agreement.

19 E. CONTRACTOR shall be required to immediately notify AUTHORITY of any modifications
20 or cancellation of any required insurance policies.

21 **ARTICLE 10. ORDER OF PRECEDENCE**

22 Conflicting provisions hereof, if any, shall prevail in the following descending order of precedence:
23 (1) the provisions of this Agreement, including all exhibits; (2) the provisions of RFP 1-3408;
24 (3) CONTRACTOR's proposal dated _____ ; (4) all other documents, if any, cited herein or
25 incorporated by reference.

26 /

1 **ARTICLE 11. CHANGES**

2 By written notice or order, AUTHORITY may, from time to time, order work suspension and/or
3 make changes in the general scope of this Agreement, including, but not limited to, the services furnished
4 to AUTHORITY by CONTRACTOR as described in the Scope of Work. If any such work suspension or
5 change causes an increase or decrease in the price of this Agreement, or in the time required for its
6 performance, CONTRACTOR shall promptly notify AUTHORITY thereof and assert its claim for
7 adjustment within ten (10) calendar days after the change or work suspension is ordered, and an
8 equitable adjustment shall be negotiated. However, nothing in this clause shall excuse CONTRACTOR
9 from proceeding immediately with the Agreement as changed.

10 **ARTICLE 12. DISPUTES**

11 A. Except as otherwise provided in this Agreement, when a dispute arises between
12 CONTRACTOR and AUTHORITY, the project managers shall meet to resolve the issue. If project
13 managers do not reach a resolution, the dispute will be decided by AUTHORITY's Director of Contracts
14 Administration and Materials Management (CAMM), who shall reduce the decision to writing and mail or
15 otherwise furnish a copy thereof to CONTRACTOR. The decision of the Director, CAMM, shall be the
16 final and conclusive administrative decision.

17 B. Pending final decision of a dispute hereunder, CONTRACTOR shall proceed diligently with
18 the performance of this Agreement and in accordance with the decision of AUTHORITY's Director,
19 CAMM. Nothing in this Agreement, however, shall be construed as making final the decision of any
20 AUTHORITY official or representative on a question of law, which questions shall be settled in
21 accordance with the laws of the State of California.

22 **ARTICLE 13. TERMINATION**

23 A. AUTHORITY may terminate this Agreement for its convenience at any time, in whole or part,
24 by giving CONTRACTOR written notice thereof. Upon said notice, AUTHORITY shall pay
25 CONTRACTOR its allowable costs incurred to date of termination and those allowable costs determined
26 by AUTHORITY to be reasonably necessary to effect such termination. Thereafter, CONTRACTOR shall

1 have no further claims against AUTHORITY under this Agreement.

2 B. In the event either Party defaults in the performance of any of their obligations under this
3 Agreement or breaches any of the provisions of this Agreement, the non-defaulting Party shall have the
4 option to terminate this Agreement upon thirty (30) days' prior written notice to the other Party. Upon
5 receipt of such notice, CONTRACTOR shall immediately cease work, unless the notice from
6 AUTHORITY provides otherwise. Upon receipt of the notice from AUTHORITY, CONTRACTOR shall
7 submit an invoice for work and/or services performed prior to the date of termination. AUTHORITY shall
8 pay CONTRACTOR for work and/or services satisfactorily provided to the date of termination in
9 compliance with this Agreement. Thereafter, CONTRACTOR shall have no further claims against
10 AUTHORITY under this Agreement. AUTHORITY shall not be liable for any claim of lost profits or
11 damages for such termination.

12 **ARTICLE 14. INDEMNIFICATION**

13 CONTRACTOR shall indemnify, defend, and hold harmless AUTHORITY, its officers, directors,
14 employees and agents from and against any and all claims (including attorneys' fees and reasonable
15 expenses for litigation or settlement) for any loss, costs, penalties, fines, damages, bodily injuries,
16 including death, damage to or loss of use of property, arising out of, resulting from, or in connection with
17 the performance of CONTRACTOR, its officers, directors, employees, agents, subcontractors or
18 suppliers under the Agreement. Notwithstanding the foregoing, such obligation to defend, hold harmless,
19 and indemnify AUTHORITY, its officers, directors, employees and agents shall not apply to such claims
20 or liabilities arising from the sole or active negligence or willful misconduct of AUTHORITY.

21 **ARTICLE 15. ASSIGNMENTS AND SUBCONTRACTS**

22 A. Neither this Agreement nor any interest herein nor claim hereunder may be assigned by
23 CONTRACTOR either voluntarily or by operation of law, nor may all or any part of this Agreement be
24 subcontracted by CONTRACTOR, without the prior written consent of AUTHORITY. Consent by
25 AUTHORITY shall not be deemed to relieve CONTRACTOR of its obligations to comply fully with all
26 terms and conditions of this Agreement.

1 B. AUTHORITY hereby consents to CONTRACTOR's subcontracting portions of the Scope of
2 Work to the parties identified below for the functions described in CONTRACTOR's proposal.
3 CONTRACTOR shall include in the subcontract agreement the stipulation that CONTRACTOR, not
4 AUTHORITY, is solely responsible for payment to the subcontractor for the amounts owing and that the
5 subcontractor shall have no claim, and shall take no action, against AUTHORITY, its officers, directors,
6 employees or sureties for nonpayment by CONTRACTOR.

7 **Subcontractor Name/Addresses**

Subcontractor Function

8
9
10 **ARTICLE 16. AUDIT AND INSPECTION OF RECORDS**

11 CONTRACTOR shall provide AUTHORITY, or other agents of AUTHORITY, such access to
12 CONTRACTOR's accounting books, records, payroll documents and facilities, as AUTHORITY deems
13 necessary. CONTRACTOR shall maintain such books, records, data and documents in accordance
14 with generally accepted accounting principles and shall clearly identify and make such items readily
15 accessible to such parties during CONTRACTOR's performance hereunder and for a period of four
16 (4) years from the date of final payment by AUTHORITY. AUTHORITY's right to audit books and
17 records directly related to this Agreement shall also extend to all first-tier subcontractors identified in
18 Article 15 of this Agreement. CONTRACTOR shall permit any of the foregoing parties to reproduce
19 documents by any means whatsoever or to copy excerpts and transcriptions as reasonably necessary.

20 **ARTICLE 17. CONFLICT OF INTEREST**

21 CONTRACTOR agrees to avoid organizational conflicts of interest. An organizational conflict
22 of interest means that due to other activities, relationships or contracts, the CONTRACTOR is unable,
23 or potentially unable to render impartial assistance or advice to the AUTHORITY; CONTRACTOR's
24 objectivity in performing the work identified in the Scope of Work is or might be otherwise impaired; or
25 the CONTRACTOR has an unfair competitive advantage. CONTRACTOR is obligated to fully disclose
26 to the AUTHORITY in writing Conflict of Interest issues as soon as they are known to the

1 CONTRACTOR. All disclosures must be submitted in writing to AUTHORITY pursuant to the Notice
2 provision herein. This disclosure requirement is for the entire term of this Agreement.

3 **ARTICLE 18. CODE OF CONDUCT**

4 CONTRACTOR agrees to comply with the AUTHORITY's Code of Conduct as it relates to
5 Third-Party contracts which is hereby referenced and by this reference is incorporated herein.
6 CONTRACTOR agrees to include these requirements in all of its subcontracts.

7 **ARTICLE 19. PROHIBITION ON PROVIDING ADVOCACY SERVICES**

8 CONTRACTOR and all subcontractors performing work under this Agreement, shall be
9 prohibited from concurrently representing or lobbying for any other party competing for a contract with
10 AUTHORITY, either as a prime CONTRACTOR or subcontractor. Failure to refrain from such
11 representation may result in termination of this Agreement.

12 **ARTICLE 20. FEDERAL, STATE AND LOCAL LAWS**

13 CONTRACTOR warrants that in the performance of this Agreement, it shall comply with all
14 applicable federal, state and local laws, statutes and ordinances and all lawful orders, rules and
15 regulations promulgated thereunder.

16 **ARTICLE 21. EQUAL EMPLOYMENT OPPORTUNITY**

17 In connection with its performance under this Agreement, CONTRACTOR shall not discriminate
18 against any employee or applicant for employment because of race, religion, color, sex, age or national
19 origin. CONTRACTOR shall take affirmative action to ensure that applicants are employed, and that
20 employees are treated during their employment, without regard to their race, religion, color, sex, age or
21 national origin. Such actions shall include, but not be limited to, the following: employment, upgrading,
22 demotion or transfer; recruitment or recruitment advertising; layoff or termination; rates of pay or other
23 forms of compensation; and selection for training, including apprenticeship.

24 **ARTICLE 22. PROHIBITED INTERESTS**

25 CONTRACTOR covenants that, for the term of this Agreement, no director, member, officer or
26 employee of AUTHORITY during his/her tenure in office or for one (1) year thereafter shall have any

1 interest, direct or indirect, in this Agreement or the proceeds thereof.

2 **ARTICLE 23. OWNERSHIP OF REPORTS AND DOCUMENTS**

3 A. The originals of all letters, documents, reports and other products and data produced under
4 this Agreement shall be delivered to, and become the property of AUTHORITY. Copies may be made
5 for CONTRACTOR's records but shall not be furnished to others without written authorization from
6 AUTHORITY. Such deliverables shall be deemed works made for hire and all rights in copyright therein
7 shall be retained by AUTHORITY.

8 B. All ideas, memoranda, specifications, plans, manufacturing, procedures, drawings,
9 descriptions, and all other written information submitted to CONTRACTOR in connection with the
10 performance of this Agreement shall not, without prior written approval of AUTHORITY, be used for any
11 purposes other than the performance under this Agreement, nor be disclosed to an entity not connected
12 with the performance of the project. CONTRACTOR shall comply with AUTHORITY's policies regarding
13 such material. Nothing furnished to CONTRACTOR, which is otherwise known to CONTRACTOR or is
14 or becomes generally known to the related industry shall be deemed confidential. CONTRACTOR shall
15 not use AUTHORITY's name, photographs of the project, or any other publicity pertaining to the project
16 in any professional publication, magazine, trade paper, newspaper, seminar or other medium without the
17 express written consent of AUTHORITY.

18 C. No copies, sketches, computer graphics or graphs, including graphic artwork, are to be
19 released by CONTRACTOR to any other person or agency except after prior written approval by
20 AUTHORITY, except as necessary for the performance of services under this Agreement. All press
21 releases, including graphic display information to be published in newspapers, magazines, etc., are to be
22 handled only by AUTHORITY unless otherwise agreed to by CONTRACTOR and AUTHORITY.

23 **ARTICLE 24. PATENT AND COPYRIGHT INFRINGEMENT**

24 A. In lieu of any other warranty by AUTHORITY or CONTRACTOR against patent or copyright
25 infringement, statutory or otherwise, it is agreed that CONTRACTOR shall defend at its expense any
26 claim or suit against AUTHORITY on account of any allegation that any item furnished under this

1 Agreement or the normal use or sale thereof arising out of the performance of this Agreement, infringes
2 upon any presently existing U.S. letters patent or copyright and CONTRACTOR shall pay all costs and
3 damages finally awarded in any such suit or claim, provided that CONTRACTOR is promptly notified in
4 writing of the suit or claim and given authority, information and assistance at CONTRACTOR's expense
5 for the defense of same. However, CONTRACTOR will not indemnify AUTHORITY if the suit or claim
6 results from: (1) AUTHORITY's alteration of a deliverable, such that said deliverable in its altered form
7 infringes upon any presently existing U.S. letters patent or copyright; or (2) the use of a deliverable in
8 combination with other material not provided by CONTRACTOR when such use in combination infringes
9 upon an existing U.S. letters patent or copyright.

10 B. CONTRACTOR shall have sole control of the defense of any such claim or suit and all
11 negotiations for settlement thereof. CONTRACTOR shall not be obligated to indemnify AUTHORITY
12 under any settlement made without CONTRACTOR's consent or in the event AUTHORITY fails to
13 cooperate fully in the defense of any suit or claim, provided, however, that said defense shall be at
14 CONTRACTOR's expense. If the use or sale of said item is enjoined as a result of such suit or claim,
15 CONTRACTOR, at no expense to AUTHORITY, shall obtain for AUTHORITY the right to use and sell
16 said item, or shall substitute an equivalent item acceptable to AUTHORITY and extend this patent and
17 copyright indemnity thereto.

18 **ARTICLE 25. FINISHED AND PRELIMINARY DATA**

19 A. All of CONTRACTOR's finished technical data, including but not limited to illustrations,
20 photographs, tapes, software, software design documents, including without limitation source code,
21 binary code, all media, technical documentation and user documentation, photoprints and other graphic
22 information required to be furnished under this Agreement, shall be AUTHORITY's property upon
23 payment and shall be furnished with unlimited rights and, as such, shall be free from proprietary restriction
24 except as elsewhere authorized in this Agreement. CONTRACTOR further agrees that it shall have no
25 interest or claim to such finished, AUTHORITY-owned, technical data; furthermore, said data is subject
26 to the provisions of the Freedom of Information Act, 5 USC 552.

1 B. It is expressly understood that any title to preliminary technical data is not passed to
2 AUTHORITY but is retained by CONTRACTOR. Preliminary data includes roughs, visualizations,
3 software design documents, layouts and comprehensives prepared by CONTRACTOR solely for the
4 purpose of demonstrating an idea or message for AUTHORITY's acceptance before approval is given
5 for preparation of finished artwork. Preliminary data title and right thereto shall be made available to
6 AUTHORITY if CONTRACTOR causes AUTHORITY to exercise Article 11, and a price shall be
7 negotiated for all preliminary data.

8 **ARTICLE 26. SETOFF**

9 If at any time, in the sole discretion of the AUTHORITY, it is reasonably believed that the
10 CONTRACTOR is liable to the AUTHORITY for any costs, penalties and/or sums, the AUTHORITY shall
11 be entitled to recover those costs, penalties and/or sums from any amounts that may be presently due
12 and payable to the CONTRACTOR or may become due and payable to the CONTRACTOR, including,
13 but not limited to payment for invoices submitted to the AUTHORITY for services provided under this
14 Agreement.

15 **ARTICLE 27. FORCE MAJEURE**

16 Either party shall be excused from performing its obligations under this Agreement during the time
17 and to the extent that it is prevented from performing by an unforeseeable cause beyond its control,
18 including but not limited to: any incidence of fire, flood; acts of God; commandeering of material, products,
19 plants or facilities by the federal, state or local government; national fuel shortage; or a material act or
20 omission by the other party; when satisfactory evidence of such cause is presented to the other party,
21 and provided further that such nonperformance is unforeseeable, beyond the control and is not due to
22 the fault or negligence of the party not performing.

23 **ARTICLE 28. HEALTH AND SAFETY REQUIREMENT**

24 CONTRACTOR shall comply with all the requirements set forth in Exhibit __, Level 2 Safety
25 Specifications.

26 /

1
2
3
4
5
6
7
8
9
10
11
12
13
14
15
16
17
18
19
20
21
22
23
24
25
26

IN WITNESS WHEREOF, the parties hereto have caused this Agreement No. C-1-3408 to be executed as of the date of the last signature below.

CONTRACTOR

ORANGE COUNTY TRANSPORTATION AUTHORITY

By: _____

By: _____

Darrell E. Johnson
Chief Executive Officer

APPROVED AS TO FORM:

By: _____

James M. Donich
General Counsel

APPROVED:

By: _____

Jennifer L. Bergener
Deputy Chief Executive Officer/
Chief Operating Officer, Operations

EXHIBIT D: STATUS OF PAST AND PRESENT CONTRACTS FORM

STATUS OF PAST AND PRESENT CONTRACTS FORM

On the form provided below, Offeror/Bidder shall list the status of past and present contracts where the firm has either provided services as a prime vendor or a subcontractor during the past five (5) years in which the contract has been the subject of or may be involved in litigation with the contracting authority. This includes, but is not limited to, claims, settlement agreements, arbitrations, administrative proceedings, and investigations arising out of the contract.

A separate form must be completed for each contract. Offeror/Bidder shall provide an accurate contact name and telephone number for each contract and indicate the term of the contract and the original contract value. Offeror/Bidder shall also provide a brief summary and the current status of the litigation, claims, settlement agreements, arbitrations, administrative proceedings, or investigations. If the contract was terminated, list the reason for termination.

Offeror/Bidder shall have an ongoing obligation to update the Authority with any changes to the identified contracts and any new litigation, claims, settlement agreements, arbitrations, administrative proceedings, or investigations that arise subsequent to the submission of the bid. Each form must be signed by an officer of the Offeror/Bidder confirming that the information provided is true and accurate.

Project city/agency/other:	
Contact Name:	Phone:
Project Award Date:	Original Contract Value:
Term of Contract:	
(1) Litigation, claims, settlements, arbitrations, or investigations associated with contract:	
(2) Summary and Status of contract:	
(3) Summary and Status of action identified in (1):	
(4) Reason for termination, if applicable:	

By signing this Form entitled "Status of Past and Present Contracts," I am affirming that all of the information provided is true and accurate.

Name

Signature

Title

Date

EXHIBIT E: CAMPAIGN CONTRIBUTION DISCLOSURE FORM

CAMPAIGN CONTRIBUTION DISCLOSURE FORM

Information Sheet

ORANGE COUNTY TRANSPORTATION AUTHORITY

The attached Campaign Contribution Disclosure Form must be completed by applicants for, or persons who are the subject of, any proceeding involving a license, permit, or other entitlement for use pending before the Board of Directors of the OCTA or any of its affiliated agencies. (Please see next page for definitions of these terms.)

IMPORTANT NOTICE

Basic Provisions of Government Code Section 84308

- A. If you are an applicant for, or the subject of, any proceeding involving a license, permit, or other entitlement for use, you are prohibited from making a campaign contribution of more than \$250 to any board member or his or her alternate. This prohibition begins on the date your application is filed or the proceeding is otherwise initiated, and the prohibition ends three months after a final decision is rendered by the Board of Directors. In addition, no board member or alternate may solicit or accept a campaign contribution of more than \$250 from you during this period.
- B. These prohibitions also apply to your agents, and, if you are a closely held corporation, to your majority shareholder as well. These prohibitions also apply to your subcontractor(s), joint venturer(s), and partner(s) in this proceeding. Also included are parent companies and subsidiary companies directed and controlled by you, and political action committees directed and controlled by you.
- C. You must file the attached disclosure form and disclose whether you or your agent(s) have in the aggregate contributed more than \$250 to any board member or his or her alternate during the 12-month period preceding the filing of the application or the initiation of the proceeding.
- D. If you or your agent have in the aggregate contributed more than \$250 to any individual board member or his/or her alternate during the 12 months preceding the decision on the application or proceeding, that board member or alternate must disqualify himself or herself from the decision. However, disqualification is not required if the board member or alternate returns the campaign contribution within 30 days from the time the director knows, or should have known, about both the contribution and the fact that you are a party in the proceeding. The Campaign Contribution Disclosure Form should be completed and filed with your proposal, or with the first written document you file or submit after the proceeding commences.

1. A proceeding involving "a license, permit, or other entitlement for use" includes all business, professional, trade and land use licenses and permits, and all other entitlements for use, including all entitlements for land use, all contracts (other than competitively bid, labor or personal employment contracts), and all franchises.
2. Your "agent" is someone who represents you in connection with a proceeding involving a license, permit or other entitlement for use. If an individual acting as an agent is also acting in his or her capacity as an employee or member of a law, architectural, engineering, consulting firm, or similar business entity, both the business entity and the individual are "agents."
3. To determine whether a campaign contribution of more than \$250 has been made by you, campaign contributions made by you within the preceding 12 months must be aggregated with those made by your agent within the preceding 12 months or the period of the agency, whichever is shorter. Contributions made by your majority shareholder (if a closely held corporation), your subcontractor(s), your joint venturer(s), and your partner(s) in this proceeding must also be included as part of the aggregation. Campaign contributions made to different directors or their alternates are not aggregated.
4. A list of the members and alternates of the Board of Directors is attached.

This notice summarizes the major requirements of Government Code Section 84308 of the Political Reform Act and California Code of Regulations, Title 2 Sections 18438-18438.8.

ORANGE COUNTY TRANSPORTATION AUTHORITY
CAMPAIGN CONTRIBUTION DISCLOSURE FORM

RFP Number: _____ RFP Title: _____

Was a campaign contribution made to any OCTA Board Member within the preceding 12 months, regardless of dollar amount of the contribution by either the proposing firm, proposed subconsultants and/or agent/lobbyist? Yes ____ No ____

If no, please sign and date below.

If yes, please provide the following information:

Prime Contractor Firm Name: _____

Contributor or Contributor Firm's Name: _____

Contributor or Contributor Firm's Address: _____

Is Contributor:

- The Prime Contractor Yes ____ No ____
- Subconsultant Yes ____ No ____
- Agent/Lobbyist hired by Prime to represent the Prime in this RFP Yes ____ No ____

Note: Under the State of California Government Code section 84308 and California Code of Regulations, Title 2, Section 18438, campaign contributions made by the Prime Contractor and the Prime Contractor's agent/lobbyist who is representing the Prime Contractor in this RFP must be aggregated together to determine the total campaign contribution made by the Prime Contractor.

Identify the Board Member(s) to whom you, your subconsultants, and/or agent/lobbyist made campaign contributions, the name of the contributor, the dates of contribution(s) in the preceding 12 months and dollar amount of the contribution. Each date must include the exact month, day, and year of the contribution.

Name of Board Member: _____

Name of Contributor: _____

Date(s) of Contribution(s): _____

Amount(s): _____

Name of Board Member: _____

Name of Contributor: _____

Date(s) of Contribution(s): _____

Amount(s): _____

Date: _____

Signature of Contributor

Print Firm Name

Print Name of Contributor

**ORANGE COUNTY TRANSPORTATION AUTHORITY (*add new director to list)
AND AFFILIATED AGENCIES**

Board of Directors

Andrew Do, Chairman

Mark A. Murphy, Vice Chairman

Lisa A. Bartlett, Director

Doug Chaffee, Director

Barbara Delgleize, Director

Katrina Foley, Director

Brian Goodell, Director

Patrick Harper, Director

Michael Hennessey, Director

Gene Hernandez, Director

Steve Jones, Director

Joseph Muller, Director

Tam Nguyen, Director

Vicente Sarmiento, Director

Tim Shaw, Director

Harry S. Sidhu, Director

Donald P. Wagner, Director

EXHIBIT F: SAFETY SPECIFICATIONS

LEVEL 2 STANDARD HEALTH, SAFETY AND ENVIRONMENTAL SPECIFICATIONS

PART I – GENERAL

1.1 GENERAL HEALTH, SAFETY & ENVIRONMENTAL REQUIREMENTS

- A. The Contractor, its subcontractors, suppliers, and employees have the obligation to comply with all Authority health, safety and environmental compliance department (HSEC), requirements of this safety specification, project site requirements, and bus yard safety rules as well as all federal, state, and local regulations pertaining to scope of work or agreements with the Authority. Additionally, manufacturer requirements are considered incorporated by reference as applicable to this scope of work.
- B. Observance of repeated unsafe acts or conditions, serious violation of safety standards, non-conformance of Authority health, safety and environmental compliance department (HSEC) requirements, or disregard for the intent of these safety specifications to protect people and property, by Contractor or its subcontractors may be reason for termination of scope or agreements with the Authority, at the sole discretion of the Authority.

C. INJURY AND ILLNESS PREVENTION PROGRAM

The Contractor shall comply with CCR Title 8, Section with California Code of Regulations (CCR) Title 8, Section 3203. The intent and elements of the IIPP shall be implemented and enforced by the Contractor and its sub-tier contractors, suppliers, and vendors. The program shall be provided to the Authority's Project Manager, upon request, within 72 hours.

D. SUBSTANCE ABUSE PREVENTION PROGRAM

Contractor shall comply with the Policy or Program of the Company's Substance Abuse Prevention Policy that complies with the most recent Drug Free Workplace Act. The program shall be provided to the Authority's Project Manager, upon request, within 72 hours.

E. HAZARD COMMUNICATION PROGRAM

- 1. Contractor shall comply with CCR Title 8, Section 5194 Hazard Communication Standard. Prior to use on Authority property and/or project work areas Contractor shall provide the Authority Project Manager copies of SDS for all applicable products used, if any. The program shall be provided to the Authority's Project Manager, upon request, within 72 hours.
- 2. All chemicals including paint, solvents, detergents and similar substances shall comply with South Coast Air Quality Management District (SCAQMD) rules 103, 1113, and 1171.

F. STORM WATER POLLUTION PREVENTION PLAN

1. The Contractor shall protect property and water resources from fuels and similar products throughout the duration of the contract. Contractor shall comply with Storm Water Pollution Prevention Plan (SWPPP) requirements. The program or plan if required by scope shall be provided to the Authority's Project Manager, upon request, within 72 hours.

G. DESIGNATED HEALTH, SAFETY, ENVIRONMENTAL (HSE) REPRESENTATIVE

1. Upon contract award, the contractor within 10 business days shall designate a health and safety representative and provide a resume and qualifications to the Authority project manager, upon request, within 72 hours.
2. This person shall be a Competent or Qualified Individual as defined by the Occupational, Safety, and Health Administration (OSHA), familiar with applicable CCR Title 8 Standards, and has the authority to affect changes in work procedures that may have associated cost, schedule and budget impacts.
3. The Contractor's HSE Representative is subject to acceptance by the Authority Project Manager, and the HSEC Department. All contact information of the HSE Representative (name, phone, and fax and pager/cell phone number) shall be provided to the Authority Project Manager, upon request, within 72 hours.
4. The Contractor's HSE Representative shall hold a current certification from the Board of Certified Safety Professionals (BCSP) and have five years of demonstrated construction/scope experience enforcing HSE compliance on construction, industrial or similar project scopes. The designated HSE Representative shall participate in any required HSE related submittals. The Authority reserves the right to allow for an exception and to modify these minimum qualification requirements for unforeseen circumstances, at the sole discretion of the Authority Project Manager and HSEC Department Manager.
5. Competent Individual means an individual who is capable of identifying existing and predictable hazards in the surroundings or working conditions which are unsanitary, hazardous, or dangerous to employees and/or property, and who has authorization to take prompt corrective measures to eliminate them.
6. Qualified Individual means an individual who by possession of a recognized degree, certificate, certification or professional standing, or who by extensive knowledge, training, and experience, has successfully demonstrated his/her ability to solve or resolve problems relating to the subject matter, the work, or the Project.

H. SCOPE PLANNING

Prior to any scope work activity or task, the Contractor shall evaluate the hazards of the scope of work and the work environment to ensure proper control measures are identified for employee public and property protection measures to prevent incidents. This evaluation shall be implemented by developing a written site specific Job Hazard Analysis (JHA) or similar tool designed for planning the work to prevent incidents. The plan shall be provided to the Authority's Project Manager, upon request, within 72 hours.

I. ORIENTATION

1. The Contractor shall conduct and document a project site safety orientation for all Contractor personnel, subcontractors, suppliers, vendors, and new employees assigned to the project prior to performing any work on Authority projects. The safety orientation at a minimum shall include, as applicable, Personal Protection Equipment (PPE) requirements, eye protection, ANSI class 2 or 3 reflective vests, designated smoking, eating, and parking areas, traffic speed limit and routing, cell phone policy, and barricade requirements. When required by scope, additional orientation shall include fall protection, energy isolation/lock-out/tag-out (LOTO), confined space, hot work permit, security requirements, and similar project safety requirements.
2. Copies of orientation documents shall be provided to the Authority Project Manager within 72 hours upon request.

J. TRAFFIC & PARKING

The Contractor shall ensure that all Contractor vehicles, including those of their subcontractors, suppliers, vendors and employees are parked in designated parking areas, personal vehicles shall be parked in the employee parking lot, work vehicles required in the maintenance area of a bus base shall be identified by company name and/or logo, covered by the company insurance, and comply with traffic routes, and posted traffic signs in areas other than the employee parking lots. Vehicles without appropriate company name and logo are considered personal vehicles and not allowed in the maintenance area of the bus base.

K. GENERAL PROVISIONS

1. The Contractor shall provide all necessary tools, equipment, and related safety protective devices to execute the scope of work in compliance with Authority's HSEC requirements, CCR Title 8 Standards, and recognized safe work practices.
2. The Contractor shall immediately notify the Authority's Project Manager whenever local, state or federal regulatory agency personnel are identified as being onsite.

3. The Authority HSEC requirements, and references contained within this scope of work shall not be considered all-inclusive as to the hazards that might be encountered. Safe work practices shall be pre-planned and performed, and safe conditions shall be maintained during the course of this work scope.
4. The Contractor shall specifically acknowledge that it has primary responsibility to prevent and correct all health, safety and environmental hazards for which it and its employees, or its subcontractors (and their employees) are responsible. The Contractor shall further acknowledge their expertise in recognition and prevention of hazards in the operations for which they are responsible, that the Authority may not have such expertise, and is relying upon the Contractor for such expertise. The Authority retains the right to notify the Contractor of potential hazards and request the Contractor to evaluate and, as necessary, to eliminate those hazards.
5. The Contractor shall instruct all its employees, and all associated sub-contractors under contract with the Contractor who work on Authority property in the recognition, identification, and avoidance of unsafe acts and/or conditions applicable to its work.
6. California Code of Regulations (CCR) Title 8 Standards are minimum requirements, and each Contractor is encouraged to exceed minimum requirements. When the Contractor safety requirements exceed statutory standards, the more stringent requirements shall be achieved for the safeguard of the public and workers.

1.2 ENVIRONMENTAL REQUIREMENTS

- A. The Contractor shall comply with Federal, State, county, municipal, and other local laws and regulations pertaining to the environment, including noise, aesthetics, air quality, water quality, contaminated soils, hazardous waste, storm water, and resources of archaeological significance. Expense of compliance with these laws and regulations is considered included in the agreement. Contractor shall provide water used for dust control, or for pre-wetting areas to be paved, as required; no payment will be made by OCTA for this water.
- B. The Contractor shall prevent pollution of storm drains, rivers, streams, irrigation ditches, and reservoirs with sediment or other harmful materials. Fuels, oils, bitumen, calcium chloride, cement, or other contaminants that would contribute to water pollution shall not be dumped into or placed where they will leach into storm drains, rivers, streams, irrigation ditches, or reservoirs. If operating equipment in streambeds or in and around open waters, protect the quality of ground water, wetlands, and surface waters.
- C. The Contractor shall protect adjacent properties and water resources from erosion and sediment damage throughout the duration of the contract. Contractor shall comply with applicable NPDES permits and Storm Water Pollution Prevention Plan (SWPPP) requirements.

- D. Contractor shall comply with all applicable EPA, Cal EPA, Cal Recycle, DTSC, SCAQMD, local, state, county and city standards, rules and regulations for hazardous and special waste handling, recycling and/ disposal. At a minimum, Contractor shall ensure compliance where applicable with SCAQMD Rule 1166, CCR Title 8, Section 5192, 29 CFR Subpart 1910.120, 49 CFR Part 172, Subpart H, 40 CFR Subpart 265.16 and CCR Title 22 Section 6625.16. Contractor shall provide OCTA a schedule of all hazardous waste and special or industrial waste disposal dates in advance of transport date. Only authorized OCTA personnel shall sign manifests for OCTA generated wastes. Contractor shall ensure that only current registered transporters are used for disposal of hazardous waste and industrial wastes. The Contractor shall obtain approval from OCTA for the disposal site locations in advance of scheduled transport date.

1.3 INCIDENT NOTIFICATION AND INVESTIGATION

- A. The Authority shall be promptly notified of any of the following types of incidents including but not limited to:
1. Damage incidents of property (incidents involving third party, contractor or Authority property damage);
 2. Reportable and/or Recordable injuries (as defined by the U. S. Occupational Safety and Health Administration), a minor injury, and near miss incidents;
 3. Incidents impacting the environment, i.e. spills or releases on Authority property.
- B. Notifications shall be made to Authority representatives, employees and/or agents. This includes incidents occurring to contractors, vendors, visitors, or members of the public that arise from the performance of Authority contract work. An immediate verbal notice followed by a written incident investigation report shall be submitted to Authority's Project Manager within 24 hours of the incident.
- C. A final written incident investigative report shall be submitted within seven (7) calendar days and include the following information. The Current Status of anyone injured, photos of the incident area, detailed description of what happened, Investigative photos of the existing conditions and area around the injury/incident scene, the contributing factors that lead to the incident occurrence, a copy of the company policy or procedure associated with the incident and evaluation of effectiveness, copy of task planning documentation, copy of the Physician's first report of injury, copy of Cal/OSHA 300 log of work related injuries and illnesses, the Cal/OSHA 301 Injury Illness Incident Report, and corrective actions initiated to prevent recurrence. This information shall be considered the minimum elements required for a comprehensive incident report provided to OCTA.

D. A Serious Injury, Serious Incident, OSHA Recordable Injury/Illness, or a Significant Near Miss shall require a formal incident review at the discretion of the Authority's Project Manager. The incident review shall be conducted within seven (7) calendar days of the incident. This review shall require a company senior executive, company program or project manager from the Contractors' organization to participate and present the incident review as determined by the OCTA Project Manager. The serious incident presentation shall include action taken for the welfare of the injured, a status report of the injured, causation factors that lead to the incident, a root cause analysis (using 5 whys and fishbone methods), and a detailed recovery plan that identifies corrective actions to prevent a similar incident, and actions to enhance safety awareness.

1. Serious Injury: includes an injury or illness to one or more employees, occurring in a place of employment or in connection with any employment, which requires inpatient hospitalization for a period in excess of twenty-four hours for other than medical observation, or in which an employee suffers the loss of any member of the body, or suffers any serious degree of physical disfigurement. A serious injury also includes a lost workday or reassignment or restricted injury case as determined by the Physician's first report of injury or Cal/OSHA definitions.
2. Serious Incident: includes but not limited to property damage of \$500.00 or more, an incident requiring emergency services (local fire, paramedics and ambulance response), news media or OCTA media relations response, and/or incidents involving other agencies (Cal/OSHA, EPA, AQMD, DTSC, Metrolink, FTA, FRA etc.) notification or representation.
3. OSHA Recordable Injury / Illness: includes and injury / illness resulting in medical treatment beyond First Aid, an injury / illness which requires restricted duty, or an injury / illness resulting in days away from work.
4. Significant Near Miss Incident: includes incidents where no property was damaged and no personal injury sustained, but where, given a slight shift in time or position, damage and/or injury easily could have occurred.

1.4 PERSONAL PROTECTIVE EQUIPMENT

Contractors, and all associated subcontractors, vendors and suppliers are required to provide their own personal protective equipment (PPE), including eye, head, foot, and hand protection, respirators, reflective safety vests, and all other PPE required to perform their work safely on Authority projects.

1.5 LANGUAGE REQUIREMENTS

The Contractor for safety reasons shall ensure employees that do not read, or understand English, shall have a bilingual supervisor or foreman when on the Authority property or projects.

1.6 WARNING SIGNS AND DEVICES

The Contractor shall provide signs, signals, and/or warning devices to be visible when and where a hazard exists. Signs, signals, and/or warning devices shall be removed when the hazard no longer exists.

1.7 REFERENCES

- A. CCR Title 8 Standards (Cal/OSHA)
- B. FCR Including 1910 and 1926 Standards
- C. NFPA, NEC, ANSI, NIOSH Standards
- D. Construction Industry Institute (CII)
- E. Board of Certified Safety Professionals (BCSP)
- F. OCTA Yard Safety Rules

END OF SECTION

EXHIBIT G: PROPOSAL EXCEPTIONS AND/OR DEVIATIONS

PROPOSAL EXCEPTIONS AND/OR DEVIATIONS

The following form shall be completed for each technical and/or contractual exception or deviation that is submitted by Offeror for review and consideration by Authority. The exception and/or deviation must be clearly stated along with the rationale for requesting the exception and/or deviation. If no technical or contractual exceptions or deviations are submitted as part of the original proposal, Offerors are deemed to have accepted Authority's technical requirements and contractual terms and conditions set forth in the Scope of Work (Exhibit A) and Proposed Agreement (Exhibit C). Offerors will not be allowed to submit this form or any contractual exceptions and/or deviation after the proposal submittal date identified in the RFP. Exceptions and/or deviations submitted after the proposal submittal date will not be reviewed by Authority.

Offeror: _____

RFP No.: _____ RFP Title: _____

Deviation or Exception No. : _____

Check one:

- Scope of Work (Technical) _____
- Proposed Agreement (Contractual) _____

Reference Section/Exhibit: _____ Page/Article No. _____

Complete Description of Deviation or Exception:

Rationale for Requesting Deviation or Exception:

Area Below Reserved for Authority Use Only:

**EXHIBIT H: PUBLIC RECORDS ACT INDEMNIFICATION – PROPOSAL
DOCUMENTS**

PUBLIC RECORDS ACT INDEMNIFICATION – PROPOSAL DOCUMENTS

Offeror is required to submit one copy of the completed and signed form as part of its proposal and it should be included only in the original proposal. Offeror shall complete either Option 1 or Option 2 which ever applies.

Option #1: Public Records Act Indemnification Agreement

By signing below, the Proposer agrees as follows regarding its Proposal:

If Authority receives a Public Records Act request (Government Code sections 6250 et seq.) which seeks any portion of Proposer’s proposal that the Proposer has marked as "confidential", "trade secret", "proprietary", "not subject to disclosure", or similar designation (the "PRA Documents"), the Authority will notify the Proposer of the request. The Proposer shall, within three business days of such notification from the Authority, inform the Authority as to whether it desires the PRA Documents to be withheld, and shall thereafter timely provide a legal basis for each such requested withholding. If the Authority determines to withhold the PRA Documents, Proposer shall indemnify and defend Authority from any and all costs or liabilities resulting from such withholding including, but not limited to, attorney fees and court costs.

Proposer shall pay all costs, immediately as they come due, pertaining to any action under the Public Records Act related to any portion of Proposer’s proposal marked or designated as described above, and withheld by Authority. If the Proposer fails to notify the Authority in writing within three business days, or to timely provide a legal basis for the withholding of documents, Proposer agrees that Authority shall release and disclose Proposer records, notwithstanding any marking or designation of the PRA Documents.

In no case shall Authority be liable for any inadvertent disclosure of any Proposer proposal documents, or any disclosure made by Authority upon a good faith belief that disclosure is required by law, or in the event Proposer has failed to notify the Authority in writing of its desire to withhold the PRA Documents within three business days and/or to timely provide a legal basis for the withholding of documents, regardless of any marking or designation of such PRA Documents, and Proposer waives any claims it may have had related to such disclosure.

Official, legal name of Proposing Firm (Type or Print)

Contact Name: _____ (Print Name)

Title: _____

Signed by: _____

Date: _____

Option #2: Non-Applicability

This Proposer has not marked any portion of its proposal as "confidential", "trade secret", "proprietary", "not subject to disclosure", or similar designation.

Official, legal name of Proposing Firm (Type or Print)

Contact Name: _____ (Print Name)

Title: _____

Signed by: _____

Date: _____